

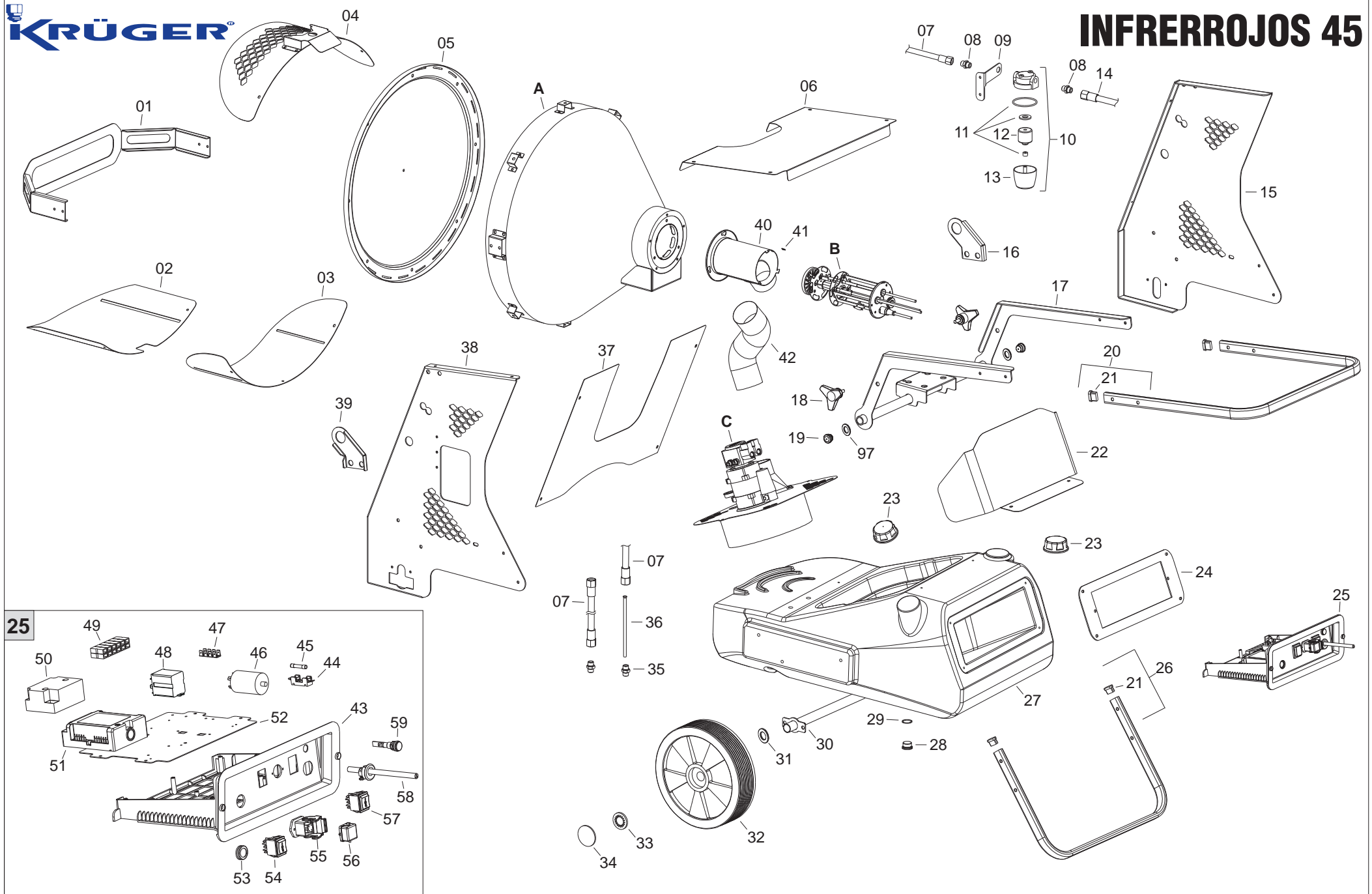

INFERRROJOS 45

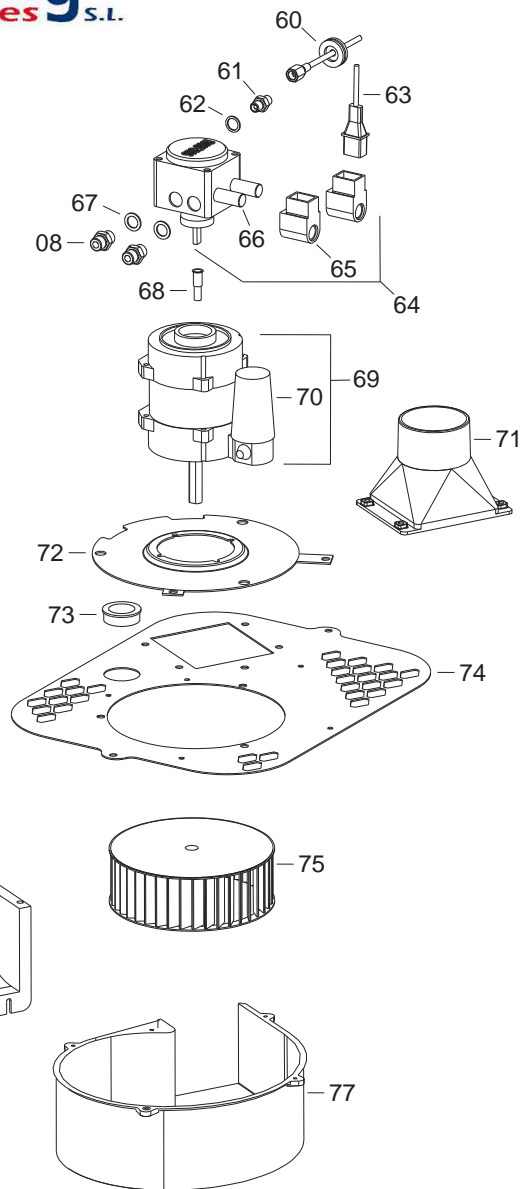

Cleaning
machines S.L.



C

B

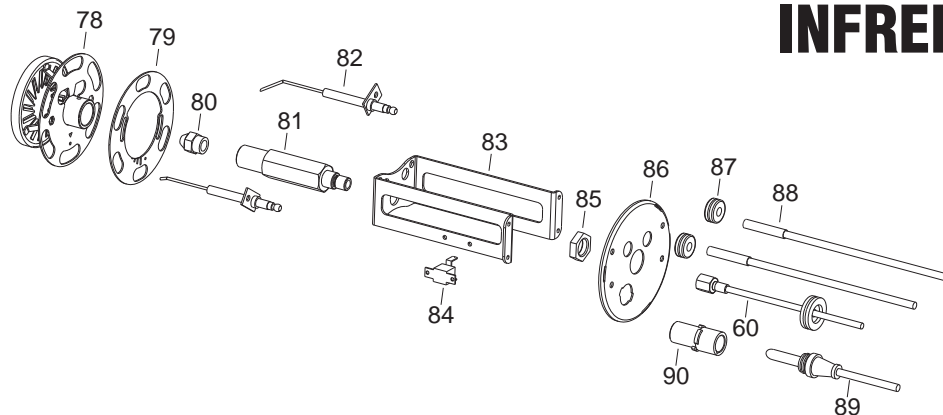

INFERRROJOS 45

Optional

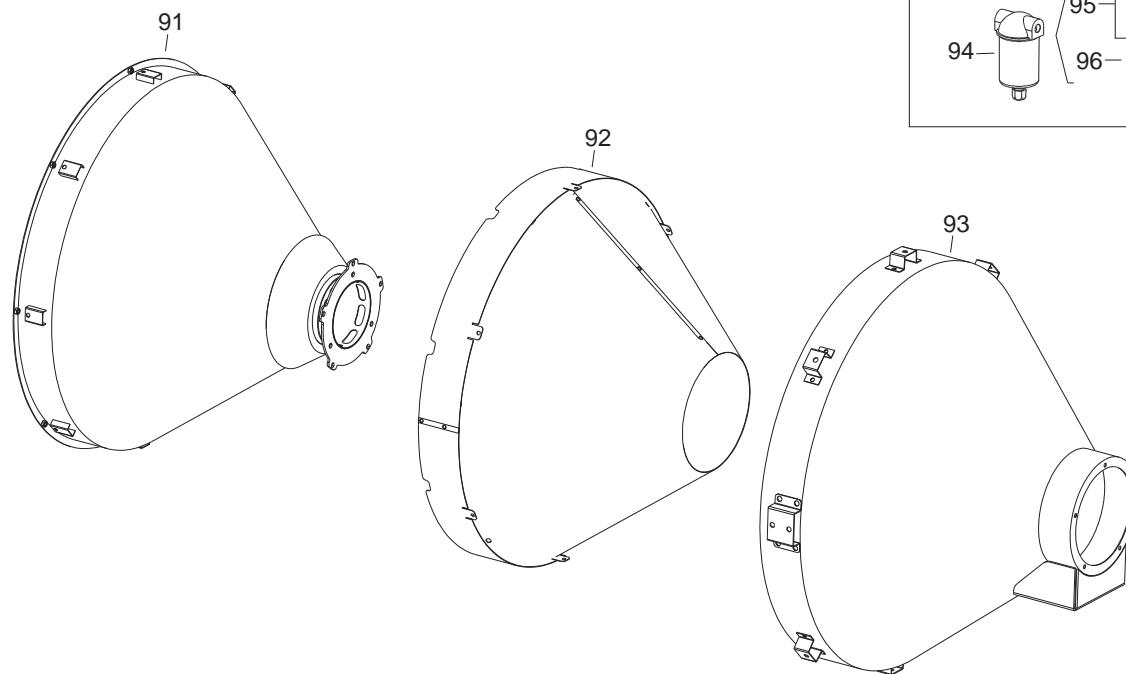
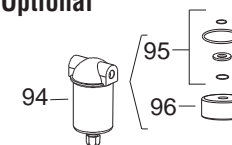

A

Pos.	Cod.	€	INFRARROJOS 45	LEGENDA	LEGENDE	NOMENKLATUR	PART LIST
01	G11001		•	Paraurto anteriore	Pare-chocs antérieur	Die Frontstoßstange	Front protection
02	G11002-N500		•	Carter inferiore mobile	Protection inférieure mobiles	Untere Schutzhaube mobil	Lower mobile protection
03	G11003-N500		•	Carter inferiore	Protection inférieure	Untere Schutzhaube	Lower protection
04	G11004-N500		•	Carter superiore	Protection supérieur	Oberer Schutzhaube	Upper protection
05	G11005		•	Disco frontale di irraggiamento	Irradiation front disque	Vordere Bremsscheibe Bestrahlung	Irradiation front disc
06	G11006-1006		•	Pannello superiore	Carrosserie sup.	Inspektionsdeckel	Upper body
07	I40329		•	Tube BP 1/4" FF L.260mm	Tube BP 1/4" FF L.260mm	Rohr BP 1/4" FF L.260mm	Tube BP 1/4" FF L.420mm
08	I20104		•	Niplo FE 1/4" MM	Niplo FE 1/4" MM	Niplo FE 1/4" MM	Niplo FE 1/4" MM
09	G06104-9005		•	Supporto filtro	Support	Stütze	Filter support
10	T20201		•	Filtro gasolio compl.	Filtere avec cartouche	Filtere komp.	Filter with cartridge
11	T20234		•	Kit OR filtro gasolio	KIT OR filtre gasoil	Kit OR heizölfilter	OR KIToil filter
12	T20206		•	Cartuccia filtro	Cartouche filtre	Filterelement	Filter cartridge
13	T20212		•	Bicchiera filtro	Cuve filtre	Filtergehäuse	Filter housing
14	I40340		•	Tube BP 1/4" FF L.580mm	Tube BP 1/4" FF L.580mm	Rohr BP 1/4" FF L.580mm	Tube BP 1/4" FF L.260mm
15	G11007-1006		•	Pannello laterale Dx	Panneau lateral droite	Seiten Beplankung rechts	Right cover plate
16	G11008-9005		•	Staffa per sollevamento dx	Étrier	der Klammer für das Hubwerk	Bracket
17	G11009-9005		•	Telaio orientamento	Châssis	Fahrgestell	Frame
18	G06322		•	Volantino PL M8x25	Croisillon M8x25	Chagriniertes handrad M8x25	Knurled wheel M8x25
19	C30335		•	Tappo copritesta Ø25 mm	Bouchon Ø25 mm	Gummifuss Ø25 mm	Plug Ø25 mm
20	P20187-9005		•	Maniglia	Poignée	Handgriff	Handle
21	C30361		•	Tappo copritesta	Bouchon	Gummifuss	Plug
22	G11010-1006		•	Pannello posteriore	Panneau postérieur	Rückwandblech	Rear panel
23	C30383		•	Tappo bocchettone	Bouchon	Pfropfen	Drain plug
24	G11011-9005		•	Supporto quadro elettrico	Support coffret électrique	Steuergeräthalerung	Electrical drawer support
25	G00289 G00290		•	Quadro elettrico	Coffret électrique	Elektrokasten	El. componets drawer
26	P20186-9005		•	Piede	Pied	Fuß	Foot
27	P50139		•	Serbatoio gasolio 65 l	Réservoir fuel 65 l	Tank 65 l	Fuel tank 65 l
28	I25020		•	Tappo Serbatoio M16x1,5 mm	Bouchon de vidange M16x1,5 mm	Abläss Propfen Oel M16x1,5 mm	Drain plug M16x1,5 mm
29	C30375		•	OR Ø16 x 2,62	OR Ø16 x 2,62	OR Ø16 x 2,62	OR Ø16 x 2,62
30	G11012-9005		•	Assale	Essieu	Achse	Wheel axle
31	M20111		•	Rondella Ø26 x Ø44 x 4	Rondelle Ø26 x Ø44 x 4	Abstandsring Ø26 x Ø44 x 4	Washer Ø26 x Ø44 x 4
32	C10555		•	Ruota Ø 300 - Ø 25	Roue Ø 300 - Ø 25	Rad Ø 300 - Ø 25	Wheel Ø 300 - Ø 25
33	M20204		•	Rondella el. block Ø 25	Clips de fixation Ø 25	Radverschluss Ø 2	Whell holder Ø 25
34	C10513-N		•	Borchia plastica	Cabochon	Deckel	Cover
35	I30737		•	Niplo OT 1/4" M - M12x1,75 M	Niplo OT 1/4" M - M12x1,75 M	Niplo OT 1/4" M - M12x1,75 M	Niplo OT 1/4" M - M12x1,75 M
36	I30696		•	Pescante L.220mm	Pascante L.220mm	Pascante L.220mm	Pascante L.220mm
37	G11013-1006		•	Pannello anteriore	Panneau frontal	Vorderen Bedienfeld	Front panel
38	G11014-1006		•	Pannello laterale Sx	Panneau lateral gauche	Seiten Beplankung links	Left cover plate
39	G11015-9005		•	Staffa per sollevamento sx	Étrier	der Klammer für das Hubwerk	Bracket
40	G11016		•	Boccaglio	Gueulard	Brennrohr	Blast tube
41	E20671		•	Morsettiera terra	Barrette de connection	Klemmreiche	Terminal board
42	I40805		•	Guaina L=350 mm	Gainne L=350 mm	Doppelmaterial-Schlauch L=350 mm	Air duct L=350 mm
43	G06153 G11017		•	Supporto quadro elettrico	Support coffret électrique	Steuergeräthalerung	Electr. componets drawer
44	E20508		•	Porta fusibile	Porte fusible	Sicherungsschalter	Fuse holder
45	E10323		•	Fusibile vetro (6x30) 16A	Fusible (6x30) 16A	Sicherung (6x30) 16A	Fuse (6x30)16A
46	E11157		•	Filtro antisturbo DEM	Filtere atipararites DEM	Funk-enstorfilter DEM	Anti-jamming filter DEM
47	E20319		•	Morsettiera terra	Barrette de connection	Klemmreiche	Terminal board
48	E11156		•	Relè Finder 65.31 AC	Relais Finder 65.31 AC	Relais Finder 65.31 AC	Relay Finder 65.31 AC
49	E20305		•	Morsettiera	Barrette de connection	Klemmreiche	Terminal board
50	E10920		•	Trasformatore A.T. TRK1 230V	Transformateur H.T. TRK1 230V	Zündtrafo H.T. TRK1 230V	Transformer H.T. TRK1 230V
51	E40122 E40127		•	Apparecchiatura BRAHMA TGRD 71 Apparecchiatura BRAHMA TGRD 92	Coffret BRAHMA TGRD 71 Coffret BRAHMA TGRD 92	Steuergerät BRAHMA TGRD 71 Steuergerät BRAHMA TGRD 92	Control box BRAHMA TGRD 71 Control box BRAHMA TGRD 92
52	G06184 G06073		•	Piastra supporto elementi elettrici	Plaqu support	Tragplatte für elektrische Teile	Plate for electrical components
53	E20418		•	Protezione pulsante blocco	Protection button d'arrêt	Blockierschalterschutz	Stop button protection
54	E10102-P		•	Interruttore bipolare 0 - 1	Interrupteur 0 - 1	Schalter 0 - 1	Switch 0 - 1
55	E20640		•	Connettore presa 3P+T	Fiche thermostat 3P+T	Thermostat stecker 3P+T	Thermostat plug 3P+T
56	E20665		•	Tappo	Bouchon	Pfropfen	Drain plug
57	E10112-P		•	Interruttore bipolare 0 - 1	Interrupteur 0 - 1	Schalter 0 - 1	Switch 0 - 1
58	E30448		•	Cavo elettrico c/spina e pressacavo	Câble avec fiche et presse câble	Kabel mit steckdose und kabelpresse	El. wire with plug and cable fastener
59	E11030		•	Lampada 230V	Lampe 230V	Kontrolllampe 230V	Lamp 230V

INFRARROJOS 45

PL 10/07

Ed. 11/10

Pos.	Cod.	€	INFRARROJOS 45	LEGENDA	LEGENDE	NOMENKLATUR	PART LIST
60	I40339		•	Microtubo L=450 mm	Microtube L=450 mm	Microschlauch L=450 mm	Micropipe L=450 mm
61	I20115		•	Nipplo FE 1/8" MM	Nipplo FE 1/8" MM	Nipplo FE 1/8" MM	Nipplo FE 1/8" MM
62	M20128		•	Rondella 1/8" x 1,5	Rondelle 1/8" x 1,5	Abstandsring 1/8" x 1,5	Washer 1/8" x 1,5
63	T20442		•	Cavo elettrovalvola	Cable electrovanne	Anschlußkabel für Magnetventil	Solenoid valve cable
64	T20410		•	Pompa BFPC21 R3 Danfoss	PompeBFPC21 R3 Danfoss	Pumpe BFPC21 R3 Danfoss	Pump BFPC21 R3 Danfoss
	T20441		•	Pompa Suntek AT2 45 BK 2S	Pompe Suntek AT2 45 BK 2S	Pumpe Suntek AT2 45 BK 2S	Pump Suntek AT2 45 BK 2S
65	T20114		•	Bobina E.V. Danfoss	Bobine E.V. Danfoss	Spule Danfoss	Solenoid spool Danfoss
	T20123		•	Bobina E.V. AT2 45 BK 2S Suntek	Bobine E.V. AT2 45 BK 2S Suntek	Spule AT2 45 BK 2S Suntek	Solenoid spool AT2 45 BK 2S Suntek
66	T20117		•	Corpo E.V. Danfoss	Electrovanne Danfoss	Magnetventil Danfoss	Solenoid valve Danfoss
	T20130		•	Coppia Corpo E.V. Suntek	Electrovanne corps couple Suntek	Magnetventil Körper Drehmoment Suntek	Solenoid valve body torque Suntek
67	M20124		•	Rondella 1/4" x 1,5	Rondelle 1/4" x 1,5	Abstandsring 1/4" x 1,5	Washer 1/4" x 1,5
68	E10698		•	Giunto Pl. mot.-pompa	Accouplement Pl.	PlastikKuplung	Coupling
69	E10705		•	Motore 200W c/condens.	Moteur 200W avec condensateur	Motor 200W mit Kondensator	Motor 200W with condenser
70	E11246		•	Condensatore 6,3 µF	Condensateur 6,3 µF	Kondensator 6,3 µF	Condenser 6,3 µF
71	C10328		•	Canale di collegamento	Canal du liaison	Connection channel	Leitungskanal
72	G06200-9005		•	Flangia motore	Support moteur et ventilateur	Lagerung Motor und Ventilator	Support fan and motor
73	C30372		•	Passacavo Ø35 mm	Protection cable Ø35 mm	Kabeltülle Ø35 mm	Cable protection Ø35 mm
74	G11025-9005		•	Supporto motore e ventilatore	Support moteur et ventilateur	Lagerung Motor und Ventilator	Support fan and motor
75	T10257		•	Ventola AP 160x70 F12,7	Ventilateur AP 160x70 F12,7	Ventilator AP 160x70 F12,7	Fan AP 160x70 F12,7
76	C10329		•	Collegamento curva 90°	Connection coude 90°	Die Verbindung der Krümmer	90° elbow connection
77	C10326		•	Chiocciola ventilatore	Ecrou ventilateur	Schnecke Ventilator	Spiral fan
78	G11018		•	Deflettore centrato	Accroche flamme	Stauscheibe	Turbo disc
79	G11019		•	Disco regolazione aria	Disque du régulation de l'air	Antrieb Luft Anpassung	Air regulation disc
80	T20363		•	Ugello 0,85 GPH 80°W	Gicleur 0,85 GPH 80°W	Düse 0,8 5 GPH 80°W	Nozzle 0,85 GPH 80°W
	T20362		•	Ugello 0,75 GPH 80°W	Gicleur 0,75 GPH 80°W	Düse 0,7 5 GPH 80°W	Nozzle 0,75 GPH 80°W
81	I33008		•	Canotto portaugello	Support gicleur	Düsehalter	Nozzle support
82	E10215		•	Elettrodi	Électrodes	Elektroden	Electrodes
83	G11020		•	Staffa elettrodi	Étrier pour électrodes	Elektrodenbügel	Electrodes stirrup
84	E50109		•	Capsula termostatica Fan	Thermostat bilame Fan	Thermostat Fan	Fan Thermostat
85	I31034		•	Controdado OT. M14	Ecrou M14	Mutter M14	Nut M14
86	G11021		•	Flangia supp. Bruciatore Ø 102mm	Bride Brûleur Ø 102mm	Brenner Flansch Ø 102mm	Burner flange Ø 102mm
87	C30368		•	Passacavo Ø12 mm	Protection cable Ø12 mm	Kabeltülle Ø12 mm	Cable protection Ø12 mm
88	G02080		•	Cavo A.T. L=1200 mm	Conn. câble H.T. L=1200 mm	H.S. Anschluß L=1200 mm	H.T. Cable connect. L=1200 mm
89	E50329		•	Fotoresistenza BRAHMA FC 13	Photoresis. BRAHMA FC 13	Fotozelle BRAHMA FC 13	Ld ph. Unit BRAHMA FC 13
90	E50327		•	Protezione fotoresistenza	Photoresistance protection	Photozellenschutz	Protection de la photoresistance
91	G11022		•	Cono interno	Cône interne	Interne Konus	Internal cone
92	G11023		•	Cono intermedio	Cône intermédiaires	Kegel	Intermediate cone
93	G11024		•	Cono esterno	Cône extérieures	Externe Konus	External cone
94	02AC569		•	Filtro gasolio c/preriscaldamento 1/4" 220V	Filtre pre-chauffage 1/4" 220V	Heizölvorwärmfilter 1/4" 220V	Oil pre-heaters filter 1/4" 220V
95	T20241		•	Kit OR filtro gasolio	KIT OR filtre gasoil	Kit OR heizölfilter	OR KIToil filter
96	T20242		•	Cartuccia filtro	Cartouche filtre	Filterelement	Filter cartridge
97	I39107		•	Guarnizione 1.1/4"	Joint 1.1/4"	Dichtung 1.1/4"	Seal 1.1/4"