



Idropulitrice 20-250 50Hz3F11kW TST

High Pressure Washer 20-250 50Hz3F11kW TST

Hochdruck Reiniger 20-250 50Hz3F11kW TST

Hidrolimpiadora 20-250 50Hz3F11kW TST

Nettoyeuse haute Pression 20-250 50Hz3F11kW

DESPIECE KH2520F

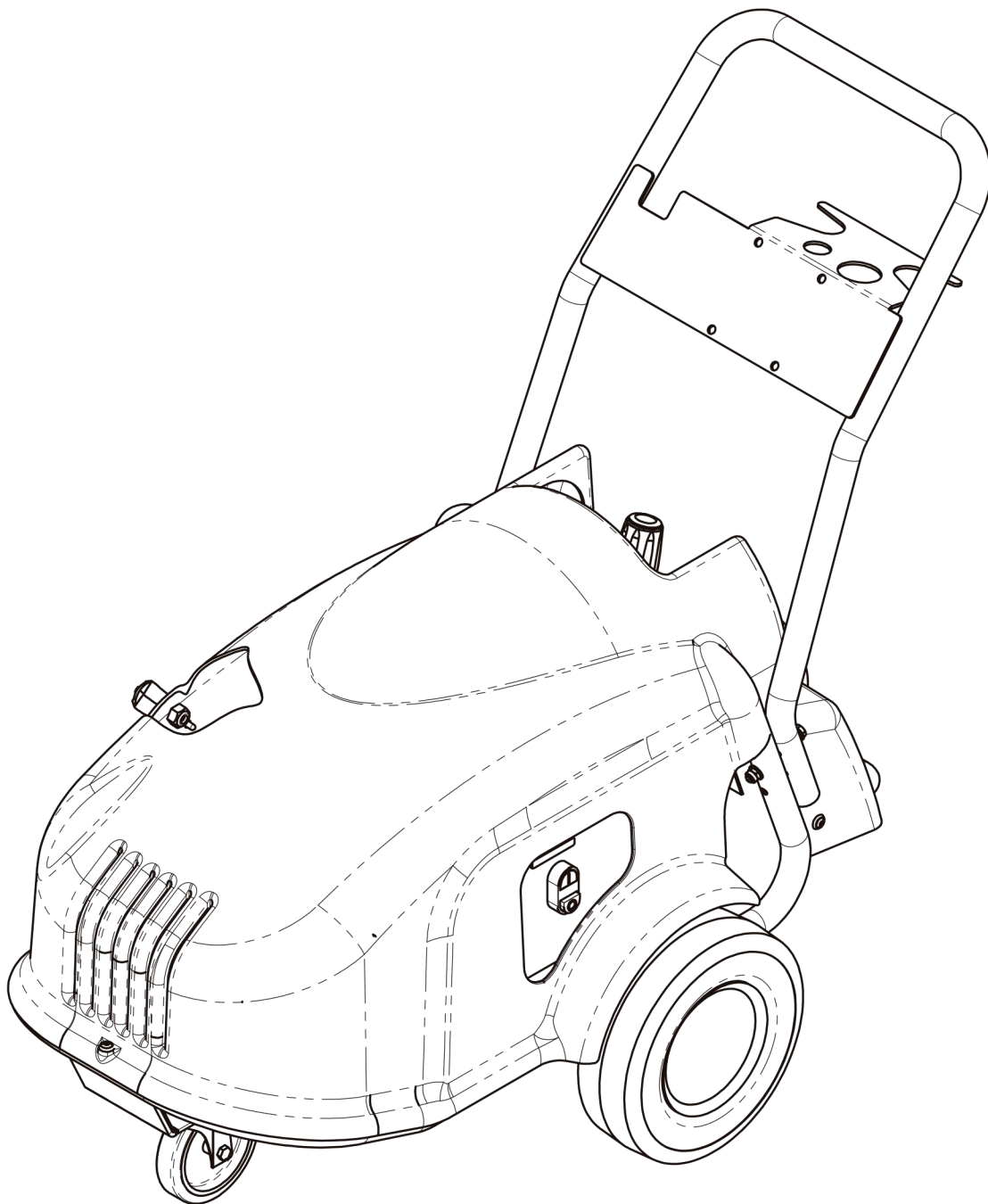

3.023.14.209 .A

DESPIECE KH2520F

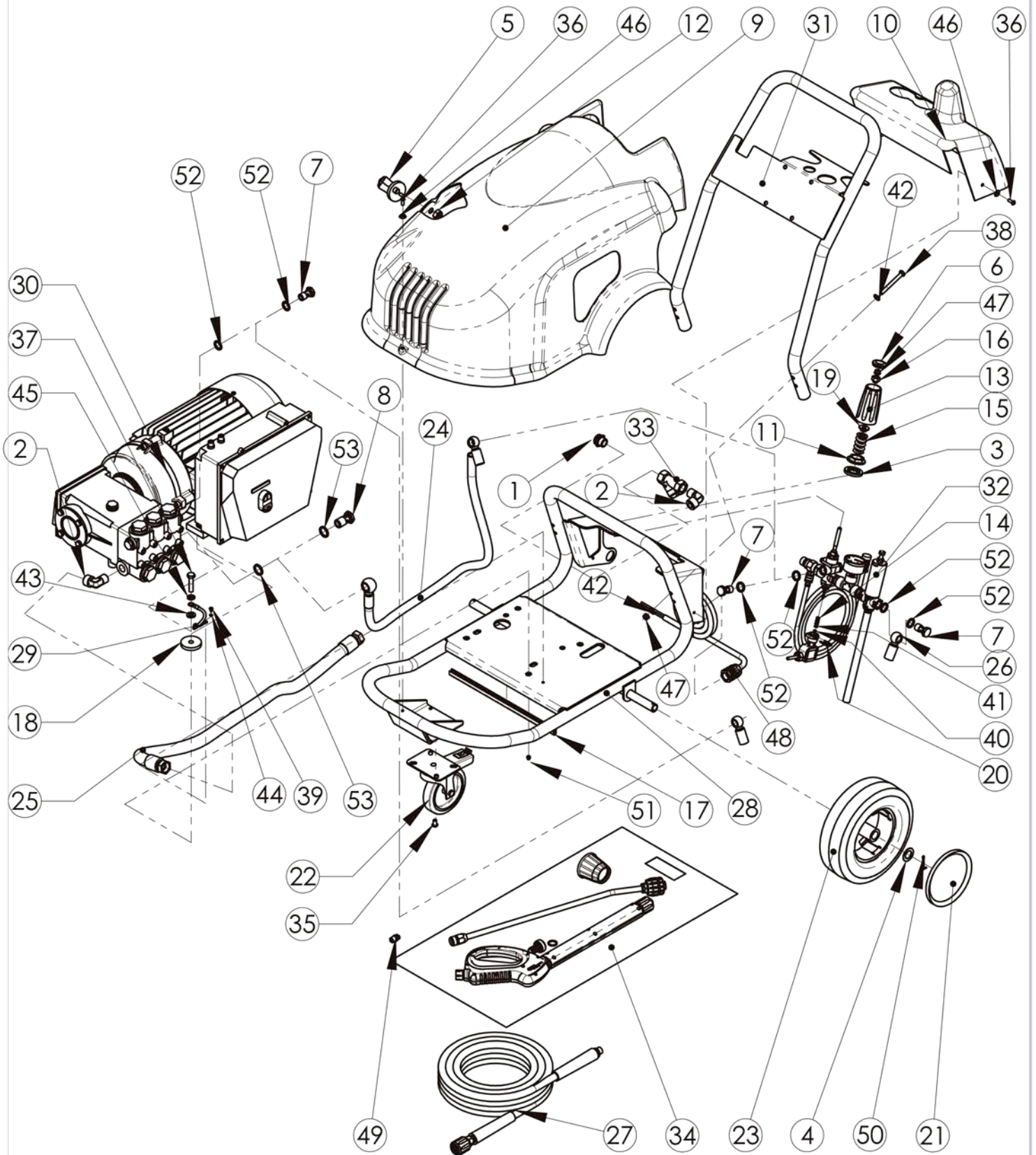

**Idropulitrice 20-250 50Hz3F11kW TST****High Pressure Washer 20-250 50Hz3F11kW TST****Hochdruck Reiniger 20-250 50Hz3F11kW TST****Hidrolimpiadora 20-250 50Hz3F11kW TST****Nettoyeuse haute Pression 20-250 50Hz3F11kW****DESPIECE KH2520F**

Pos.	Q.tà	Cod.	ITALIANO	INGLESE	TEDESCO	SPAGNOLO	FRANCESE
1	1	1.001.02.007	Raccordo G3/4 - G1/2	Connection G3/4 - G1/2	Leiste G3/4 - G1/2	Filete G3/4 - G1/2	Filet G3/4 - G1/2
2	2	1.001.14.015	Raccordo a L G1/2 - G3/4	L Connection G1/2 - G3/4	Leiste L G1/2 - G3/4	Filete L G1/2 - G3/4	Filet L G1/2 - G3/4
3	1	1.003.04.009	Rondella VBR KC5000	Washer VBR KC5000	Unterlegscheibe VBR KC5000	Arandela VBR KC5000	Rondelle VBR KC5000
4	2	1.003.04.014	Rondella ø35xø20x1.5	Washer ø35xø20x1.5	Unterlegscheibe ø35xø20x1.5	Arandela ø35xø20x1.5	Rondelle ø35xø20x1.5
5	1	1.011.04.049	Supporto porta lancia G1/4	lance holder G1/4	Lanzehalter G1/4	Sostenedor de la lanza G1/4	Support de lance G1/4
6	1	1.012.02.005	Tappo	Cap	Deckel	Tapón	Bouchon
7	3	1.012.14.003	Tappo 3/8	Cap 3/8	Deckel 3/8	Tapn 3/8	Bouchon 3/8
8	1	1.012.14.004	Tappo G1/2	Cap G1/2	Deckel G1/2	Tapón G1/2	Bouchon G1/2
9	1	1.014.14.039	Scocca Blu KC5000-5050	Blue Cover KC5000-5050	Blauer Abdeckung KC5000-5050	Tapa Azul KC5000-5050	Copot Bleu KC5000-5050
10	1	1.014.14.040	Scocca KC5000-5050	Cover KC5000-5050	Abdeckung KC5000-5050	Tapa KC5000-5050	Copot KC5000-5050
11	1	1.015.24.006	Ghiera M27x1 VBR KC5000	Ferrule M27x1 VBR KC5000	Zwinge M27x1 VBR KC5000	Abrazadera M27x1 VBR KC5000	Embout M27x1 VBR KC5000
12	1	1.015.32.008	Ghiera G1/4"	Ferrule G1/4"	Zwinge G1/4"	Abrazadera G1/4"	Embout G1/4"
13	1	1.021.02.012	Manopla	Knob	Griff	Pomo	Poignée
14	1	1.025.12.010	Molla P115	Spring P115	Feder P115	Muelle P115	Ressort P115
15	1	1.025.22.001	Molla	Spring	Feder	Muelle	Ressort
16	1	1.036.02.001	Inserto M8	Insert M8	Einsatz M8	Inserto M8	Insert M8
17	2	1.046.04.006	Protezione "V" L360	Protection "V" L360	Scuhtz "V" L360	Protección "V" L360	Protection "V" L360
18	4	1.060.04.017	Distanziale ø50xø11xø7.8	Spacer ø50xø11xø7.8	Distanzstueck ø50xø11xø7.8	Distanciador ø50xø11xø7.8	Entretoise ø50xø11xø7.8
19	1	1.072.02.004	Premimolla	Spring clamp	Federdruecker	Prensamuelle	Presse-ressort
20	1	1.081.02.001	Forcella	Fork	Gabel	Horquilla	Fourche
21	2	1.085.04.009	Coprizzo ø260	Hub Cap ø260	Nabe Haus ø260	Casquillo del cubo ø260	Enjoliveur de roue ø260
22	1	1.086.04.003	Ruota girevole PK125R	Revolving wheel PK125R	Drehbares Rad PK125R	Rueda giratoria PK125R	Roue pivotante PK125R
23	2	1.086.04.009	Ruota ø260X21 SPV	Wheel ø260X21 SPV	Rad ø260X21 SPV	Rueda ø260X21 SPV	Roue ø260X21 SPV
24	1	2.006.04.027	Tubo 13x20 40bar L840 3/8-1/2	Pipe 13x20 40bar L840 3/8-1/2	Rohr 13x20 40bar L840 3/8-1/2	Tubo 13x20 40bar L840 3/8-1/2	Tuyau 13x20 40bar L840 3/8-1/2
25	1	2.006.04.044	Tubo ø19x30 20bar L1030 2x3/4"F	Pipe ø19x30 20bar L1030 2x3/4"F	Rohr ø19x30 20bar L1030 2x3/4"F	Tubo ø19x30 20bar L1030 2x3/4"F	Tuyau ø19x30 20bar L1030 2x3/4"F
26	1	2.006.24.026	Tubo 1/2"R2 400Bar L850 2x3\8	Pipe 1/2"R2 400Bar L850 2x3\8	Rohr 1/2"R2 400Bar L850 2x3\8	Tubo 1/2"R2 400Bar L850 2x3\8	Tuyau 1/2"R2 400Bar L850 2x3\8
27	1	2.006.24.038	Tubo 3/8 400Bar R2 10m M22 - G3/8-M	Pipe 3/8 400Bar R2 10m M22 - G3/8-M	Rohr 3/8 400Bar R2 10m M22 - G3/8-M	Tubo 3/8 400Bar R2 10m M22 - G3/8-M	Tuyau 3/8 400Bar R2 10m M22 - G3/8-M
28	1	2.015.04.008	Telaio KC5000-5025-5050-6000	Frame KC5000-5025-5050-6000	Rahmen KC5000-5025-5050-6000	Estructura KC5000-5025-5050-6000	Chassis KC5000-5025-5050-6000
29	1	2.020.14.089	Cavo L150	Cable L150	Kabel L150	Cable L150	Cable L150
30	1	2.034.14.068	Motopompa + Quadro elettrico KC5025 20-250 400V50H	Motorpump + Electric pannel KC5025 20-250 400V50Hz	Motorpumpe + Schalltafel KC5025 20-250 400V50Hz	Motobomba + Cuadro eléctrico KC5025 20-250 400V50H	Motopompe + Cadre électrique KC5025 20-250 400V50H
31	1	2.042.04.003	Manico	Handle	Griff	Manija	Manche
32	1	2.058.04.003	Gruppo valvola KC5000 TST	Valves Group KC5000 TST	Ventil Gruppe KC5000 TST	Groupe Vannes KC5000 TST	Grupo Valvulas KC5000 TST
33	1	3.032.02.001	Filtro Y 1/2G	Filter Y 1/2G	Filter Y 1/2G	Filtro Y 1/2G	Filtere Y 1/2G
34	1	3.045.04.006	Kit accessori KC5000	Accessories kit KC5000	Kit Zubehör KC5000	Kit accesorios KC5000	Kit accessoires KC5000
35	4	4.002.14.021	Vite M8x14 ISO7380	Screw M8x14 ISO7380	Schrauben M8x14 ISO7380	Tornillo M8x14 ISO7380	Vis M8x14 ISO7380
36	3	4.002.17.004	Vite M6x16 ISO 7380	Screw M6x16 ISO 7380	Schrauben M6x16 ISO 7380	Tornillo M6x16 ISO 7380	Vis M6x16 ISO 7380
37	4	4.002.44.013	Vite M10x45 UNI 5737-65	Screw M10x45 UNI 5737-65	Schrauben M10x45 UNI 5737-65	Tornillo M10x45 UNI 5737-65	Vis M10x45 UNI 5737-65
38	4	4.002.44.017	Vite M8x75 UNI5737	Screw M8x75 UNI5737	Schrauben M8x75 UNI5737	Tornillo M8x75 UNI5737	Vis M8x75 UNI5737
39	1	4.002.94.015	Vite autofilettante 3.9x9.5	Self-tapping Screw 3.9x9.5	Selbschneidendeschraube 3.9x9.5	Tornillo autoblocante 3.9x9.5	Vis autofiletant 3.9x9.5
40	1	4.005.22.003	OR 2015	O-ring 2015	O-Ring 2015	OR 2015	Joint torique 2015
41	1	4.008.02.002	Rondella ø4.3xø8x0.5 (OT)	Washer ø4.3xø8x0.5 (OT)	Unterlegscheibe ø4.3xø8x0.5 (OT)	Arandela M4.3xø8x0.5 (OT)	Rondelle ø4.3xø8x0.5 (OT)
42	8	4.008.04.002	Rondella M8 UNI6592	Washer M8 UNI6592	Unterlegscheibe M8 UNI6592	Arandela M8 UNI6592	Rondelle M8 UNI6592
43	4	4.008.04.004	Rondella M10 UNI6592	Washer M10 UNI6592	Unterlegsscheibe M10 UNI6592	Arandela M10 UNI6592	Rondelle M10 UNI6592
44	1	4.008.54.001	Rondella di sicurezza UNI8842 M4	Safety washer UNI8842 M4	Sicherheits Scheibe UNI8842 M4	Arandela de seguridad UNI8842 M4	Rondelle de sûreté UNI8842 M4
45	4	4.008.54.003	Rondella M10 UNI1751-A	Washer M10 UNI1751-A	Unterlegscheibe M10 UNI1751-A	Arandela M10 UNI1751-A	Rondelle M10 UNI1751-A
46	3	4.008.67.001	Rondella ø6xø16x3 UNI6594	Washer ø6xø16x3 UNI6594	Unterlegscheibe ø6xø16x3 UNI6594	Arandela ø6xø16x3 UNI6594	Rondelle ø6xø16x3 UNI6594
47	5	4.009.12.001	Dado M8 UNI7474	Nut M8 UNI7474	Mutter M8 UNI7474	Dado M8 UNI7474	Ecrou M8 UNI7474
48	1	4.026.02.002	Pressacavo PG16	Cable clamping PG16	Kabelklemme PG16	Prensacables PG16	Serre-câble PG16
49	1	4.027.02.044	Ugello SA1\4MEG-1506 INOX	Nozzle SA1\4MEG-1506 INOX	Duse SA1\4MEG-1506 INOX	Boquilla SA1\4MEG-1506 INOX	Buse SA1\4MEG-1506 INOX
50	2	4.044.04.004	Copiglia ø3.2x36 UNI1336	Spit-pin ø3.2x36 UNI1336	Splint ø3.2x36 UNI1336	Chavefa ø3.2x36 UNI1336	Goupille ø3.2x36 UNI1336
51	4	4.047.04.001	Inserto M10	Insert M10	Einsatz M10	Inserto M10	Insert M10
52	6	4.070.04.001	Guarnizione G3/8	Gasket G3/8	Dichtung G3/8	Guarnición G3/8	GarnitureG3/8
53	2	4.070.04.002	Guarnizione G1/2	Gasket G1/2	Dichtung G1/2	Guarnición G1/2	GarnitureG1/2

DESPIECE KH2520F

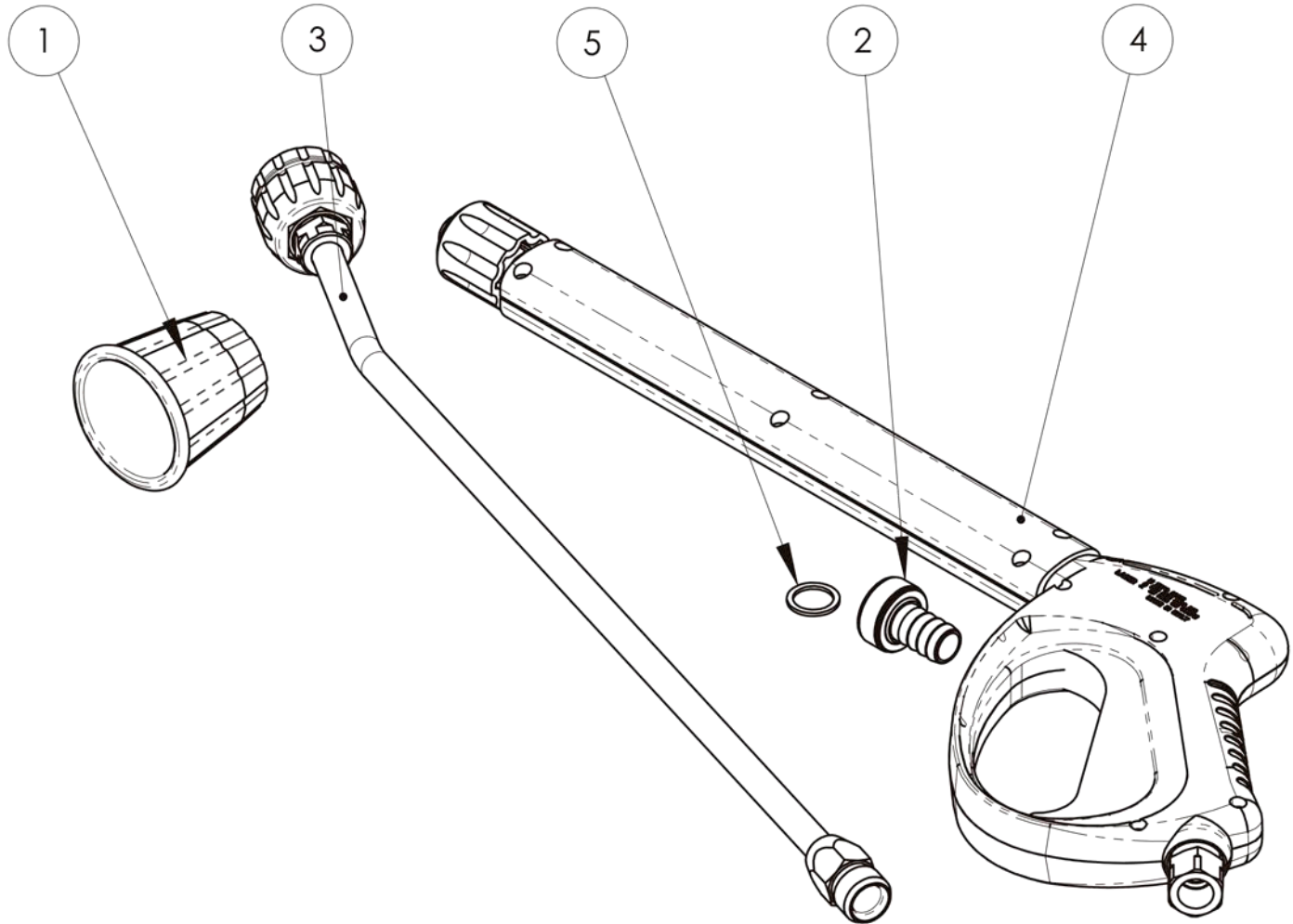

3.045.04.006 .A

Pos.	Q.tà	Cod.	ITALIANO	INGLESE	TEDESCO	SPAGNOLO	FRANCESE
1	1	1.046.02.015	Protezione	Protection	Schutz	Protección	Protection
2	1	2.021.02.003	Attacco rapido	Quick coupling	Schnelle Kupplung	Ataque rapido	Connection rapide
3	1	3.020.22.021	Prolunga + Testina Regolabile L=500	Extension and Adjustable head L=500	Verlängerung und Einstellbarer Kopf L=500	Prolongacion + Cabeza regulable L=500	Rallonge + Tête réglable L=500
4	1	3.021.22.003	Pistola + Impugnatura "LASER" G3/8" F Sweevel	Trigger Gun + Grip "LASER" G3/8" F Sweevel	Pistole + Handgriff "LASER" G3/8" F Sweevel	Pistola + Empunadura "LASER" G3/8" F Sweevel	Pistolet + Branche "LASER" G3/8" F Sweevel
5	1	4.008.12.001	Rondella Rame G3/8	Copper washer G3/8	Kupferunterlegsscheibe G3/8	Arandela de cobre G3/8	Rondelle cuivre G3/8

Gruppo valvola TST

Valves Group TST
Grupo Valvulas TST

Ventil Gruppe TST
Groupe Vannes TST

DESPIECE KH2520F

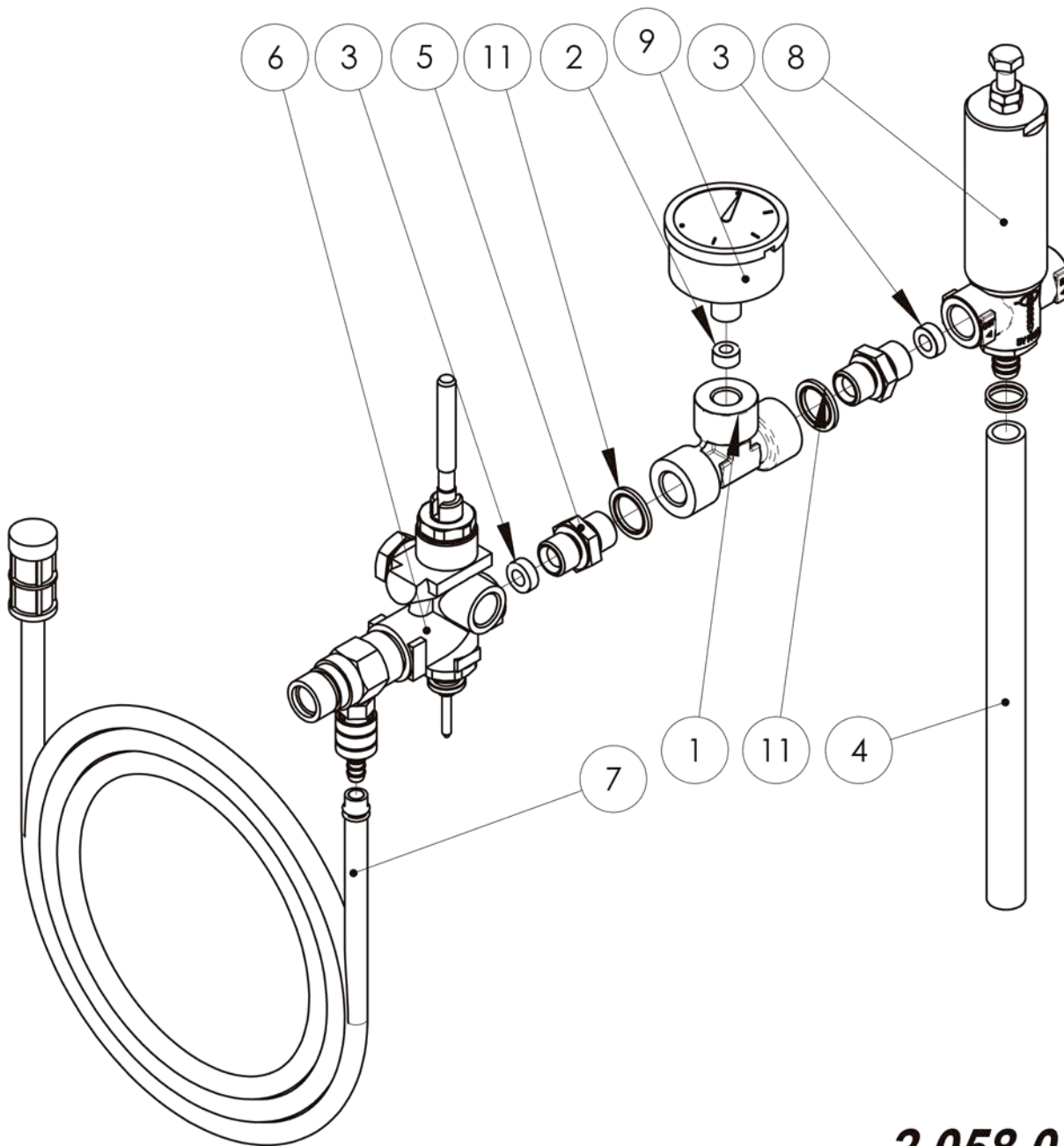

2.058.04.003 .E

Pos.	Q.ta	Cod.	ITALIANO	INGLESE	TEDESCO	SPAGNOLO	FRANCESE
1	1	1.001.24.008	Raccordo T 3/8GFF 1/4F	Connection T 3/8GFF 1/4F	Leiste T 3/8GFF 1/4F	Filete T 3/8GFF 1/4F	Filet T 3/8GFF 1/4F
2	1	1.006.11.007	Guarnizione 6x11.8x6	Gasket 6x11.8x6	Dichtung 6x11.8x6	Guarnición 6x11.8x6	Garniture 6x11.8x6
3	2	1.006.22.001	Guarnizione 14.7x7.7x5.3	Gasket 14.7x7.7x5.3	Dichtung 14.7x7.7x5.3	Guarnición 14.7x7.7x5.3	Garniture 14.7x7.7x5.3
4	1	1.044.44.017	Tubo VITREX 11x16x250	Pipe VITREX 11x16x250	Rohr VITREX 11x16x250	Tubo VITREX 11x16x250	Tuyau VITREX 11x16x250
5	2	1.096.04.001	Nipples	Nipples	Nipples	Nipples	Nipples
6	1	2.003.34.012	Valvola di regolazione Pressione 250bar30l\min TST	Pressure unloader valve 250bar 30l\min TST	Druckregelventile 250bar 30l\min TST	Válvula reguladores de presion 250bar 30l\min TST	Valve regulateur de presion 250bar 30l\min TST
7	1	2.074.04.044	Tubo aspirazione MH	Suction pipe MH	Saugrohr MH	Tubo de aspiración MH	Tube d'aspiration MH
8	1	3.003.22.006	Valvola di sicurezza 250Bar G3/8-FF	Safety pressure valve 250Bar G3/8-FF	Max druck Einstellungsventile 250Bar G3/8-FF	Valvula de seguridad 250Bar G3/8-FF	Soupape de presion maximal 250Bar G3/8-FF
9	1	4.020.14.002	Manometro 50 400B G1/4	Pressure gauge 50 400B G1/4	Druckmesser 50 400B G1/4	Manómetro 50 400B G1/4	Manomètre 50 400B G1/4
10	1	4.022.04.009	Fascetta AUTOSERRANTI 16	Clamp AUTOSERRANTI 16	Klemme AUTOSERRANTI 16	Faja AUTOSERRANTI 16	Petif bande AUTOSERRANTI 16
11	2	4.070.04.001	Guarnizione G3/8	Gasket G3/8	Dichtung G3/8	Guarnición G3/8	GarnitureG3/8

Valvola di regolazione Pressione 250bar30l/min TST

Pressure unloader valve 250bar 30l/min TST

Druckregelventile 250bar 30l/min TST

Valve regulateur de presion 250bar 30l/min TST Válvula reguladores de presion 250bar 30l/min TST

DESPIECE KH2520F

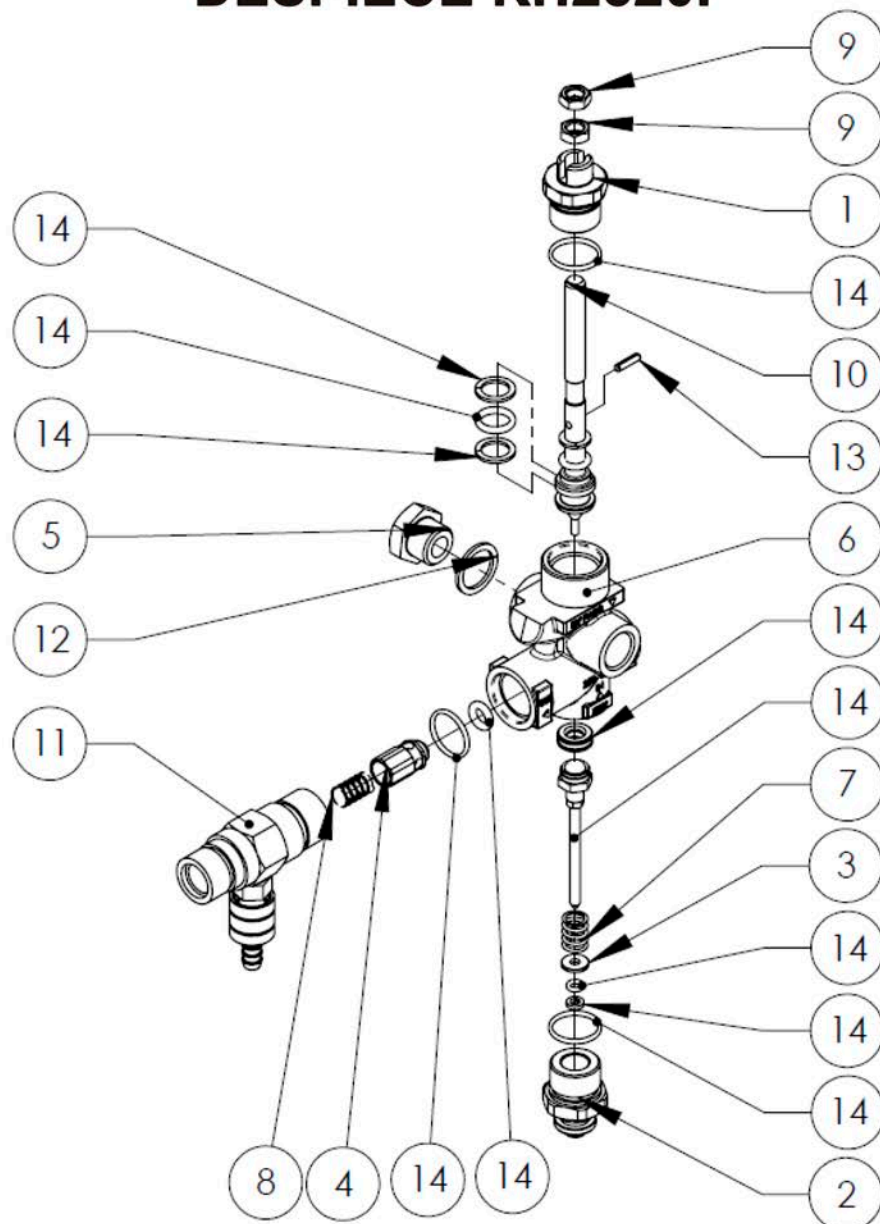

2.003.34.012 .C

Pos.	Q.tà	Cod.	ITALIANO	INGLESE	TEDESCO	SPAGNOLO	FRANCESE
1	1	1.001.02.002	Raccordo M20x3\8	Connection M20x3\8	Leiste M20x3\8	Filete M20x3\8	Filet M20x3\8
2	1	1.001.02.024	Raccordo	Connection	Leiste	Filete	Filet
3	1	1.003.02.004	Rondella ø4x11x1.5	Washer ø4x11x1.5	Unterlegscheibe ø4x11x1.5	Arandela ø4x11x1.5	Rondelle ø4x11x1.5
4	1	1.007.02.001	Otturatore	Shutter	Obturador	Verschluss	Obtuteur
5	1	1.012.12.001	Tappo G3/8"	Cap G3/8"	Deckel G3/8"	Tapón G3/8"	Bouchon G3/8"
6	1	1.020.22.020	Corpo	Body	Körper	Cuerpo	Corps
7	1	1.025.12.002	Molla 15x1.4	Spring 15x1.4	Feder 15x1.4	Muelle 15x1.4	Ressort 15x1.4
8	1	1.025.12.003	Molla ø0.7xø9xh21	Spring ø0.7xø9xh21	Feder ø0.7xø9xh21	Muelle ø0.7xø9xh21	Ressort ø0.7xø9xh21
9	2	1.035.02.001	Dado M8	Nut M8	Mutter M8	Dado M8	Ecrou M8
10	1	1.037.02.001	Stelo VRB	Stem VRB	Spindel VRB	Vastago VRB	Tige VRB
11	1	3.016.12.012	* Iniettore M22x1.5 M20x1.5 MM REG.2.2	* Injector M22x1.5 M20x1.5 MM REG.2.2	* Iniektor M22x1.5 M20x1.5 MM REG.2.2	* Inyector M22x1.5 M20x1.5 MM REG.2.2	* Iniecteur M22x1.5 M20x1.5 MM REG.2.2
12	1	4.008.12.001	Rondella Rame G3/8	Copper washer G3/8	Kupferunterlegsscheibe e G3/8	Arandela de cobre G3/8	Rondelle cuivre G3/8
13	1	4.011.12.001	Spina	Plug	Stecker	Enchufe	Prise
14	1	9.003.02.007	Kit Tenute	Spare seals kit	Kit Dichtungen	Kit cierres	Kit joints détanchéité

*OPTIONAL

Valvola di sicurezza 250Bar G3/8-FF

Safety pressure valve 250Bar G3/8-FF

Max druck Einstellungsventile 250Bar G3/8-FF

Soupape de pression maximal 250Bar G3/8-FF

Valvula de seguridad 250Bar G3/8-FF

DESPIECE KH2520F

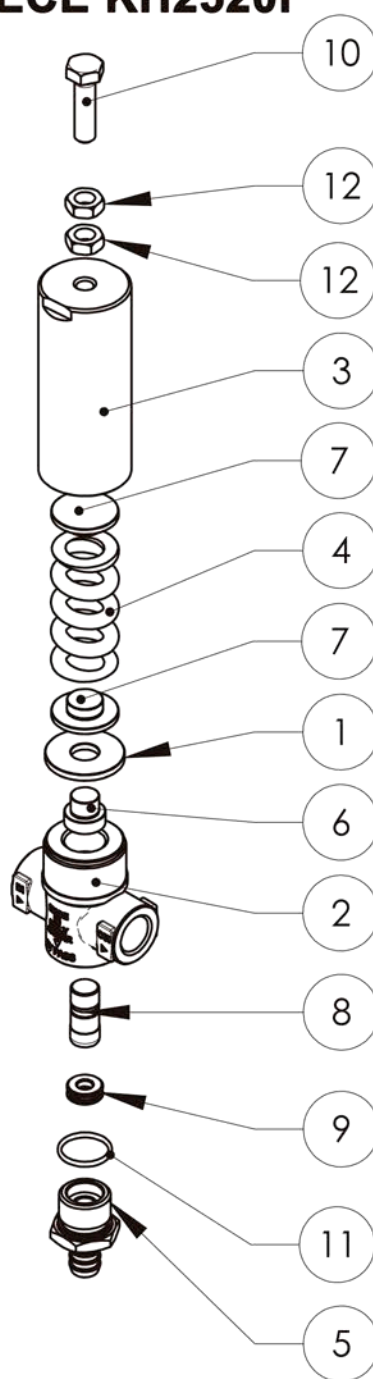

3.003.22.006 .B

Pos.	Q.tà	Cod.	ITALIANO	INGLESE	TEDESCO	SPAGNOLO	FRANCESE
1	1	1.003.04.018	Rondella	Washer	Unterlegscheibe	Arandela	Rondelle
2	1	1.020.22.022	Corpo	Body	Körper	Cuerpo	Corps
3	1	1.020.22.023	Corpo VS 250BAR	Body VS 250BAR	Körper VS 250BAR	Cuerpo VS 250BAR	Corps VS 250BAR
4	1	1.025.22.001	Molla	Spring	Feder	Muelle	Ressort
5	1	1.049.02.007	Portagomma ø12xM20x1.5 M	Hose fitting ø12xM20x1.5 M	Schlauchhalter ø12xM20x1.5 M	Portamanguera ø12xM20x1.5 M	Raccord pour tuyau ø12xM20x1.5 M
6	1	1.071.02.010	Pistone	Piston	Kolben	Pistón	Piston
7	2	1.072.02.016	Premimolla	Spring clamp	Federdrücker	Prensamuelle	Presse-ressort
8	1	2.002.02.004	Otturatore	Shutter	Obturador	Verschluss	Obturateur
9	1	2.051.02.001	Seeger	Seeger	Seeger	Seeger	Seeger
10	1	4.002.42.003	Vite M8x30 UNI5739	Screw M8x30 UNI5739	Schrauben M8x30 UNI5739	Tornillo M8x30 UNI5739	Vis M8x30 UNI5739
11	1	4.005.21.011	OR 2068	O-ring 2068	O-ring 2068	OR 2068	Joint torique 2068
12	2	4.009.04.003	Dado M8 UNI5589	Nut M8 UNI5589	Mutter M8 UNI5589	Dado M8 UNI5589	Ecrou M8 UNI5589

Motopompa + Quadro elettrico 20-250 400V50H

Motorpump + Electric pannel 20-250 400V50Hz

Motorpumpe + Schalttafel 20-250 400V50Hz

Motopompe + Cadre électrique 20-250 400V50H

Motobomba + Cuadro eléctrico 20-250 400V50H

DESPIECE KH2520F

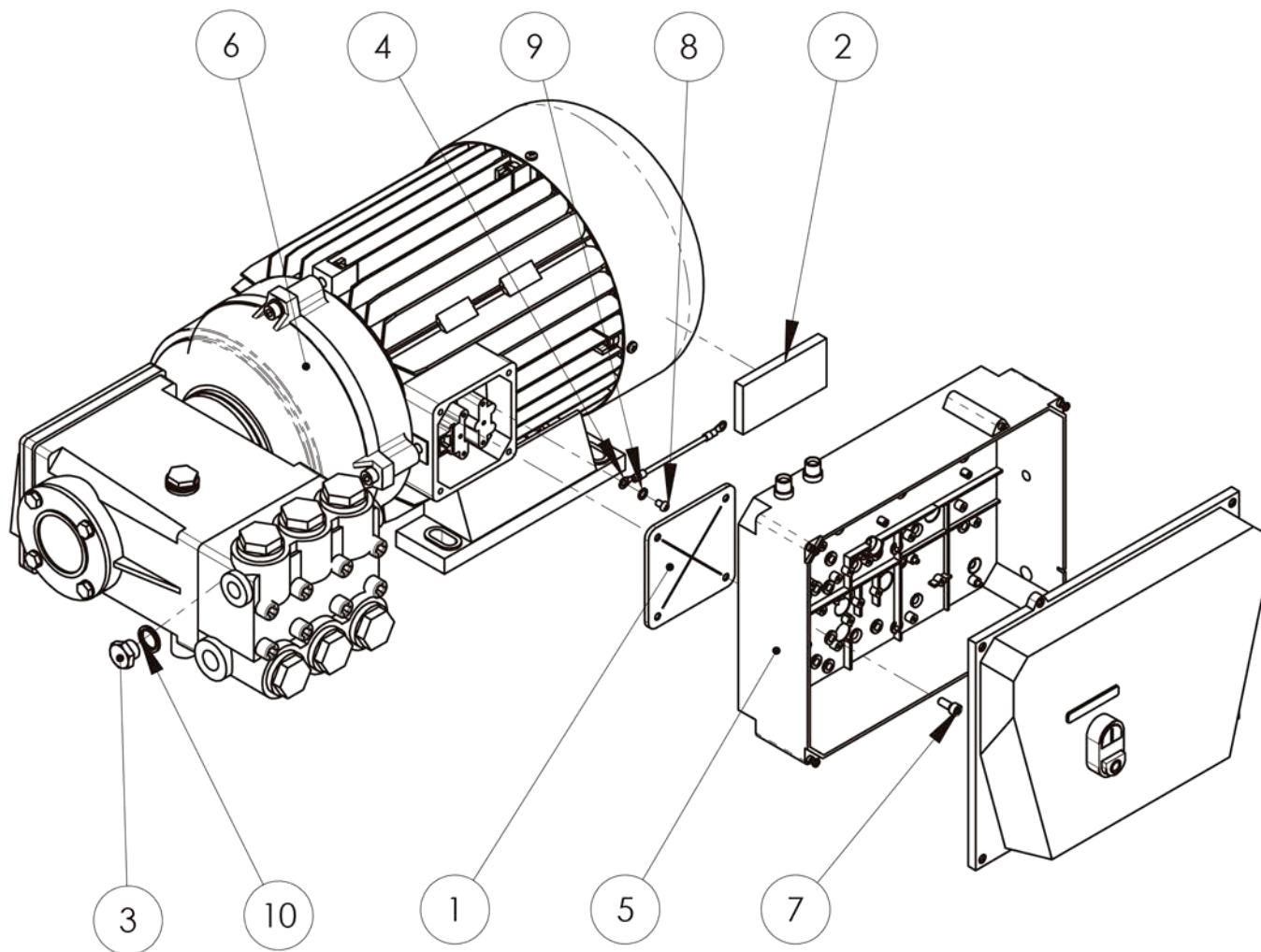

2.034.14.068 .A

Pos.	Q.ta	Cod.	ITALIANO	INGLESE	TEDESCO	SPAGNOLO	FRANCESE
1	1	1.006.12.011	Guarnizione U IP44	Gasket U IP44	Dichtung U IP44	Guarnición U IP44	Garniture U IP44
2	1	1.006.14.011	Guarnizione 50x10x100	Gasket 50x10x100	Dichtung 50x10x100	Guarnición 50x10x100	Garniture 50x10x100
3	1	1.012.12.001	Tappo G3/8"	Cap G3/8"	Deckel G3/8"	Tapón G3/8"	Bouchon G3/8"
4	1	2.020.14.045	Cavo elettrico 2.5 GV L=280	Power cable 2.5 GV L=280	Energie kabel 2.5 GV L=280	Cable eléctrico 2.5 GV L=280	Cable électrique 2.5 GV L=280
5	1	2.031.04.101	Quadro elettrico KC5025-50 6000 400V3F50Hz11kW TST	Electric pannel KC5025-50 6000 400V3F50Hz11kW TST	Schalttafel KC5025-50 6000 400V3F50Hz11kW TST	Cuadro eléctrico KC5025-50 6000 400V3F50Hz11kW TST	Cadre électrique KC5025-50 6000 400V3F50Hz11kW TST
6	1	3.006.12.069	Motopompa T32M B3BL 3F400V50Hz4P 11kW+HC932	Motorpump T32M B3BL 3F400V50Hz4P 11kW+HC932	Motorpumpe T32M B3BL 3F400V50Hz4P 11kW+HC932	Motobomba T32M B3BL 3F400V50Hz4P 11kW+HC932	Motopompe T32M B3BL 3F400V50Hz4P 11kW+HC932
7	4	4.002.12.013	Vite M6x16 UNI5931	Screw M6x16 UNI5931	Schrauben M6x16 UNI5931	Tornillo M6x16 UNI5931	Vis M6x16 UNI5931
8	1	4.002.74.003	Vite M5x8 UNI7687	Screw M5x8 UNI7687	Schrauben M5x8 UNI7687	Tornillo M5x8 UNI7687	Vis M5x8 UNI7687
9	1	4.008.52.001	Rondella di sicurezza M6	Safety washer M6	Sicherheits Scheibe M6	Arandela de seguridad M6	Rondelle de sûreté M6
10	1	4.070.04.001	Guarnizione G3/8	Gasket G3/8	Dichtung G3/8	Guarnición G3/8	Garniture G3/8

Motorpompa 132M B3BL 3F400V50Hz4P 11kW+HC932

Motorpump 132M B3BL 3F400V50Hz4P 11kW+HC932

Motorpumpe 132M B3BL 3F400V50Hz4P 11kW+HC932

Motopompe 132M B3BL 3F400V50Hz4P 11kW+HC932

Motobomba 132M B3BL 3F400V50Hz4P 11kW+HC932

DESPIECE KH2520F

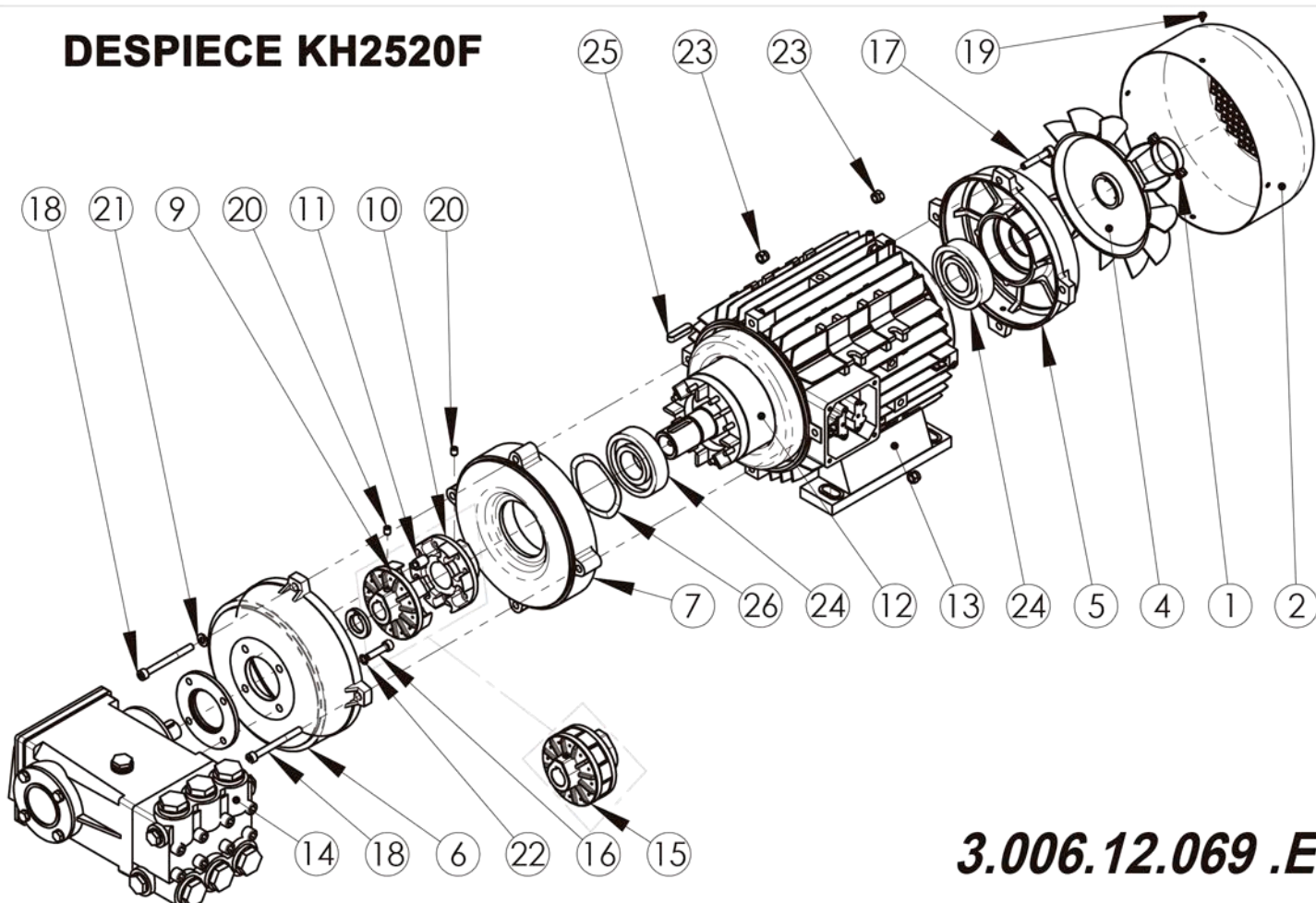

3.006.12.069 .E

Pos.	Q.tà	Cod.	ITALIANO	INGLESE	TEDESCO	SPAGNOLO	FRANCESE
1	1	1.045.02.007	Fascetta Ventola MEC 132	Clamp Impeller MEC 132	Klemme Antereiber MEC 132	Faja Implador MEC 132	Petit bande Roue à aubes MEC 132
2	1	1.046.02.017	Protezione ventola MEC 132	Fan protection MEC 132	Antrieberschutz MEC 132	Protección del ventilador MEC 132	Protection du ventilateur MEC 132
3	1	1.060.04.021	Distanziale	Spacer	Distanzstueck	Distanciador	Entretoise
4	1	1.073.02.005	Ventola M132M	Impeller M132M	Antereiber M132M	Implador M132M	Roue à aubes M132M
5	1	1.074.02.012	Flangia posteriore MEC 132	back flange MEC 132	Rückseitiger Flansch MEC 132	Reborde trasero MEC 132	Bride arrier MEC 132
6	1	1.074.02.031	Flangia anteriore MEC 132	Front flange MEC 132	Forderer Flansch MEC 132	Reborde delantero MEC 132	Bride avant MEC 132
7	1	1.074.02.032	Flangia lato pompa MEC 132	Pump side flange MEC 132	Pumpe seitlicher Flansch MEC 132	Reborde lateral de la bomba MEC 132	Bride lateral de pompe MEC 132
8	1	1.074.02.039	Flangia Mec132-HC932	Flange Mec132-HC932	Flansch Mec132-HC932	Borde Mec132-HC932	Bride Mec132-HC932
9	1	1.131.02.009	Mozzo MEC132 ø24	Hub MEC132 ø24	Nabe MEC132 ø24	Cubo MEC132 ø24	Moyeu MEC132 ø24
10	1	1.131.02.010	Mozzo G132 ø38	Hub G132 ø38	Nabe G132 ø38	Cubo G132 ø38	Moyeu G132 ø38
11	12	1.157.02.001	Ammortizzatore	Cushion	Dämpfer	Amortiguador	Amortisseur
12	1	2.014.02.043	Albero Premontato	Preassembled shaft	Vormontierung welle	Preensamblado eje	Préassemblé arbre
13	1	2.017.02.026	Carter Montato M132M BL 4P50Hz11kW	Assembled Guard M132M BL 4P50Hz11kW	Montiertes Gehäuse M132M BL 4P50Hz11kW	Ensamblado Carter M132M BL 4P50Hz11kW	Carter assemblé M132M BL 4P50Hz11kW
14	1	3.015.12.030	Pompa HC932R	Pump HC932R	Pump HC932R	Bomba HC932R	Pompe HC932R
15	1	3.055.02.001	Giunto ø24/ø38	Coupling ø24/ø38	Kupplung ø24/ø38	Acoplamiento ø24/ø38	Accouplement ø24/ø38
16	4	4.002.12.009	Vite M8x35 UNI 5931	Screw M8x35 UNI 5931	Schrauben M8x35 UNI 5931	Tornillo M8x35 UNI 5931	Vis M8x35 UNI 5931
17	4	4.002.12.018	Vite M8x45 UNI5931	Screw M8x45 UNI5931	Schrauben M8x45 UNI5931	Tornillo M8x45 UNI5931	Vis M8x45 UNI5931
18	4	4.002.12.021	Vite M8x85 UNI5931	Screw M8x85 UNI5931	Schrauben M8x85 UNI5931	Tornillo M8x85 UNI5931	Vis M8x85 UNI5931
19	4	4.002.94.010	Vite autofilettante UNI6954 4.8x9.5	Self-tapping Screw UNI6954 4.8x9.5	Selbschneidendeschraube UNI6954 4.8x9.5	Tornillo autobloccante UNI6954 4.8x9.5	Vis autofiletant UNI6954 4.8x9.5
20	2	4.004.42.005	Grano M8x10 UNI 5929	Grub screw M8x10 UNI 5929	Duebel M8x10 UNI 5929	Grano M8x10 UNI 5929	Grain M8x10 UNI 5929
21	1	4.008.04.002	Rondella M8 UNI6592	Washer M8 UNI6592	Unterlegscheibe M8 UNI6592	Arandela M8 UNI6592	Rondelle M8 UNI6592
22	4	4.008.52.002	Rondella di sicurezza UNI8842 M8	Safety washer UNI8842 M8	Sicherheits Scheibe UNI8842 M8	Arandela de seguridad UNI8842 M8	Rondelle de sûreté UNI8842 M8
23	6	4.009.14.001	Dado M8 UNI7473	Nut M8 UNI7473	Mutter M8 UNI7473	Dado M8 UNI7473	Ecrou M8 UNI7473
24	2	4.016.02.007	Cuscinetto SKF6308 ZZ C3 40x90x23	Bearing SKF6308 ZZ C3 40x90x23	Kugellager SKF6308 ZZ C3 40x90x23	Rodamiento SKF6308 ZZ C3 40x90x23	Roulement SKF6308 ZZ C3 40x90x23
25	1	4.021.02.003	Chiaveffa 10x8x40 UNI6604-A	Key 10x8x40 UNI6604-A	Keil 10x8x40 UNI6604-A	Chaveta 10x8x40 UNI6604-A	Clavette 10x8x40 UNI6604-A
26	1	4.049.12.004	Anello di compensazione B90 6308	Compression ring B90 6308	Kompressionring B90 6308	Anillo de compresión B90 6308	Anneau de compression B90 6308

Quadro elettrico 400V3F50Hz11kW TST

Electric pannel 400V3F50Hz11kW TST

Schalttafel 400V3F50Hz11kW TST

Cadre électrique 400V3F50Hz11kW TST

Cuadro eléctrico 400V3F50Hz11kW TST

DESPIECE KH2520F

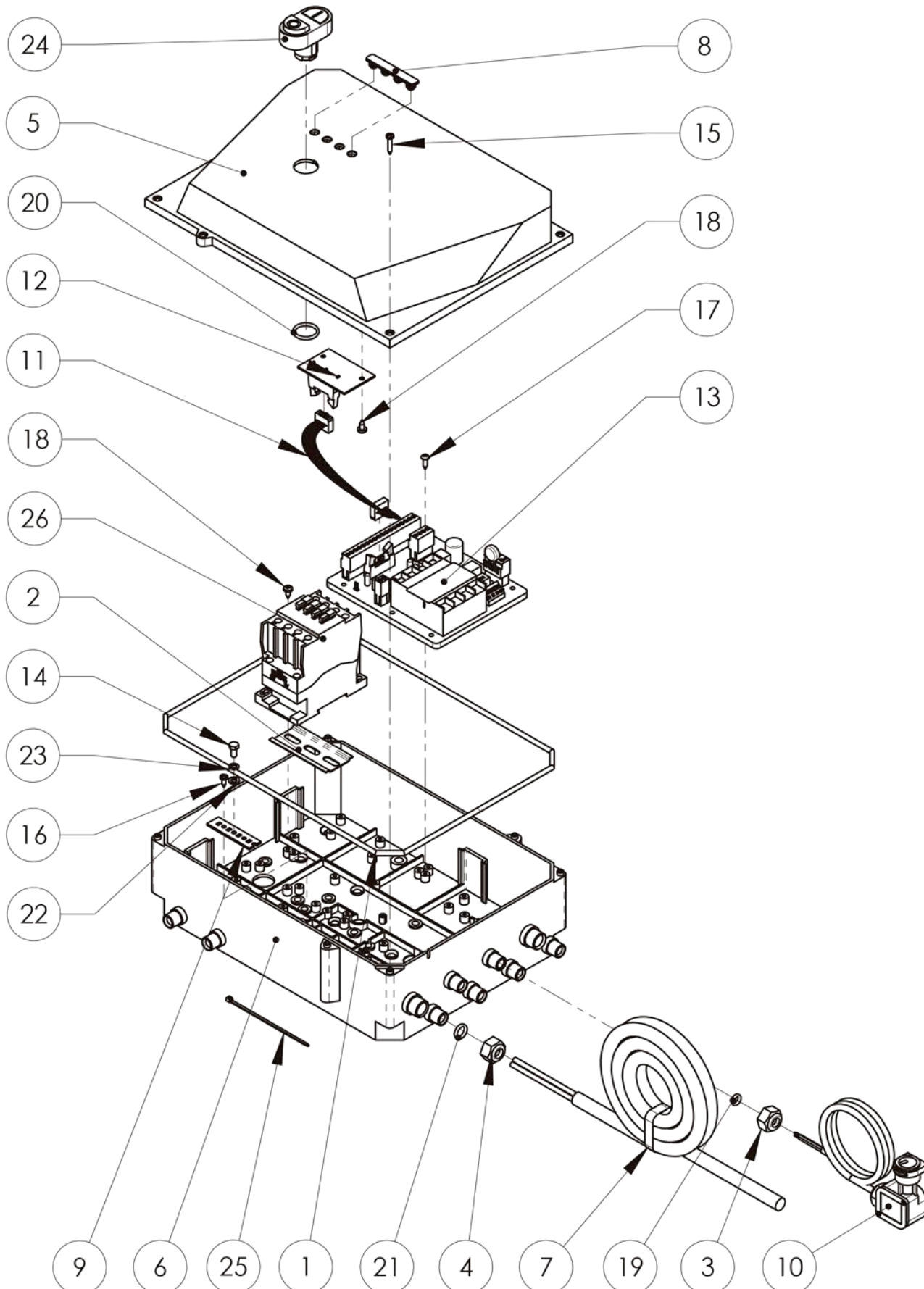

2.031.04.101 .B

DESPIECE KH2520F

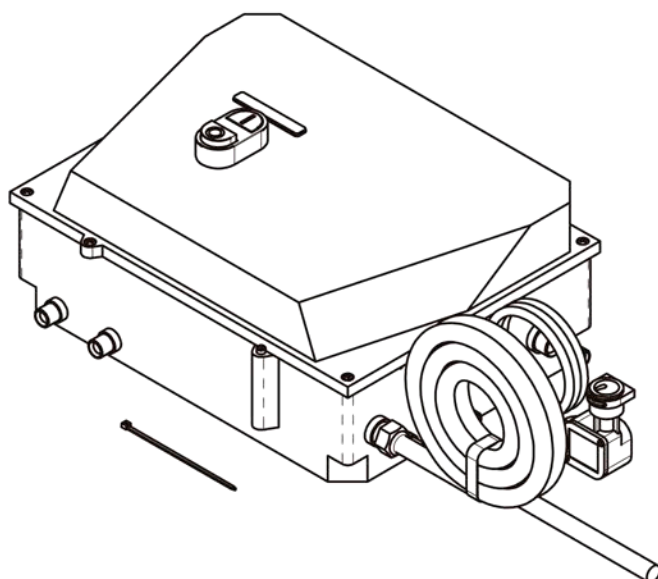

2.031.04.101.B

Pos.	Q.tà	Cod.	ITALIANO	INGLESE	TEDESCO	SPAGNOLO	FRANCESE
1	1	1.006.14.004	Guarnizione ø4x1020	Gasket ø4x1020	Dichtung ø4x1020	Guarnición ø4x1020	Garniture ø4x1020
2	1	1.011.04.033	Supporto OMEGA L73	Support OMEGA L73	Halter OMEGA L73	Soporte OMEGA L73	Support OMEGA L73
3	1	1.015.32.008	Ghiera G1/4"	Ferrule G1/4"	Zwinge G1/4"	Abrazadera G1/4"	Embout G1/4"
4	1	1.015.32.011	Ghiera	Ferrule	Zwinge	Abrazadera	Embout
5	1	1.054.04.015	Coperchio K5000	Cover K5000	Deckel K5000	Tapa K5000	Couvercle K5000
6	1	1.078.04.022	Scatola elettrica 310x230x82 KC5000- 5050	Electric case 310x230x82 KC5000- 5050	Elektrokasten 310x230x82 KC5000- 5050	Caja eléctrica 310x230x82 KC5000- 5050	boîte électrique 310x230x82 KC5000- 5050
7	1	1.088.04.044	Cavo elettrico	Power cable	Energie kabel	Cable electrico	Cable électrique
8	1	1.102.04.002	Vetrino	Glass	Glass	Vidrio	Vèrre
9	1	1.128.04.002	Morsetto L55	Clamp L55	Klemme L55	Prensita de sujeción L55	Colier de serrage L55
10	1	2.008.02.002	Pressostato S2	pressure gauge S2	Druckschalter S2	Presostato S2	Pressostat S2
11	1	2.020.32.002	Cavo L380 BL	Cable L380 BL	Kabel L380 BL	Cable L380 BL	Cable L380 BL
12	1	3.024.02.019	Scheda MCC10/15	Board MCC10/15	Karte MCC10/15	Tarjeta MCC10/15	Carte MCC10/15
13	1	3.024.02.023	Scheda elettronica MCC15-M	Electronic Board MCC15-M	ElektronischeKarte MCC15-M	Tarjeta electrónico MCC15-M	Carte électronique MCC15-M
14	2	4.002.44.011	Vite M5x10 UNI5739	Screw M5x10 UNI5739	Schrauben M5x10 UNI5739	Tornillo M5x10 UNI5739	Vis M5x10 UNI5739
15	4	4.002.92.001	Vite autofilettante 3.5x19	Self-tapping Screw 3.5x19	Selbschneidendeschra ube 3.5x19	Tornillo autoblocante 3.5x19	Vis autofiletant 3.5x19
16	1	4.002.92.003	Vite autofilettante 3.5x10 AB	Self-tapping Screw 3.5x10 AB	Selbschneidendeschra ube 3.5x10 AB	Tornillo autoblocante 3.5x10 AB	Vis autofiletant 3.5x10 AB
17	4	4.002.94.005	Vite autofilettante 3.9x13	Self-tapping Screw 3.9x13	Gewindeschneidschra ube 3.9x13	Tornillo Self-tapping 3.9x13	Vies Autofiletante 3.9x13
18	4	4.002.94.015	Vite autofilettante 3.9x9.5	Self-tapping Screw 3.9x9.5	Selbschneidendeschra ube 3.9x9.5	Tornillo autoblocante 3.9x9.5	Vis autofiletant 3.9x9.5
19	1	4.005.22.009	OR 3024	O-ring 3024	O-ring 3024	OR 3024	Joint torique 3024
20	1	4.005.22.025	OR 3075	O-ring 3075	O-Ring 3075	OR 3075	Joint torique 3075
21	1	4.005.24.001	OR 112	O-ring 112	O-Ring 112	OR 112	Joint torique 112
22	2	4.008.04.005	Rondella M5 UNI6592	Washer M5 UNI6592	Unterlegsscheibe M5 UNI6592	Arandela M5 UNI6592	Rondelle M5 UNI6592
23	2	4.008.54.002	Rondella di sicurezza UNI8842 M5	Safety washer UNI8842 M5	Sicherheits Scheibe UNI8842 M5	Arandela de seguridad UNI8842 M5	Rondelle de sûreté UNI8842 M5
24	1	4.018.04.008	Interruttore ø22	Switch ø22	Schalter ø22	Interruptor ø22	Interrupteur ø22
25	1	4.022.04.004	Fascetta 2.5x100	Clamp 2.5x100	Klemme 2.5x100	Faja 2.5x100	Petit bande 2.5x100
26	1	4.042.04.019	Teleruttore	Remote control switch	Fernschalter	Telerruptor	Telerupteur