

Pos.	Cod.	Descrizione	Description	Descripción	N°
01a	4.027.02.034	Ugello W4000	Nozzle W4000	Tobera W4000	1
01b	4.027.02.071	Ugello W4050	Nozzle W4050	Tobera W4050	1
02	3.022.12.034	Lancia	Lance	Lanza	1
03	3.021.22.003	Pistola	Trigger gun	Pistola	1
04	2.006.24.038	Tubo	Tube	Tubo	1
05	1.085.04.011	Coprimozzo nero	Black hub-cap	Tapacubos negro	4
06a	2.049.24.043	Premontato idro W4000 "Hawk"	Preassembled idro W4000 "Hawk"	Preensamblado idro W4000 "Hawk"	1
06b	2.049.24.050	Premontato idro W4000 "Interpump"	Preassembled idro W4000 "Interpump"	Preensamblado idro W4000 "Interpump"	1
06c	2.049.44.044	Premontato idro W4050 "Hawk"	Preassembled idro W4050 "Hawk"	Preensamblado idro W4050 "Hawk"	1
06d	2.049.24.013	Premontato idro W4050 "Interpump"	Preassembled idro W4050 "Interpump"	Preensamblado idro W4050 "Interpump"	1
07a	1.014.14.025	Scocca blu	Blue cover	Bastidor azul	1
07b	1.014.14.027	Scocca rossa	Red cover	Bastidor rojo	1
07c	1.014.14.028	Scocca gialla	Yellow cover	Bastidor amarillo	1
08	4.002.12.007	Vite M6x35	M6x35 screw	Tornillo M6x35	1
09	1.011.04.030	Supporto porta lancia	Washing gun holder suport	Soporte porta-pistola de lavado	1
10	4.008.24.001	Rondella	Washer	Arandela	2
11	4.002.12.008	Vite M6x25	M6x25 screw	Tornillo M6x25	1
12	4.002.14.021	Vite M8x14	M8x14 screw	Tornillo M8x14	4
13	1.003.04.012	Rondella PVC	PVC washer	Arandela PVC	4
14	4.008.12.001	Rondella rame 3/8"G	3/8"G copper washer	Arandela 3/8"G	1

PROLUNGA – EXTENSION – ALARGADOR

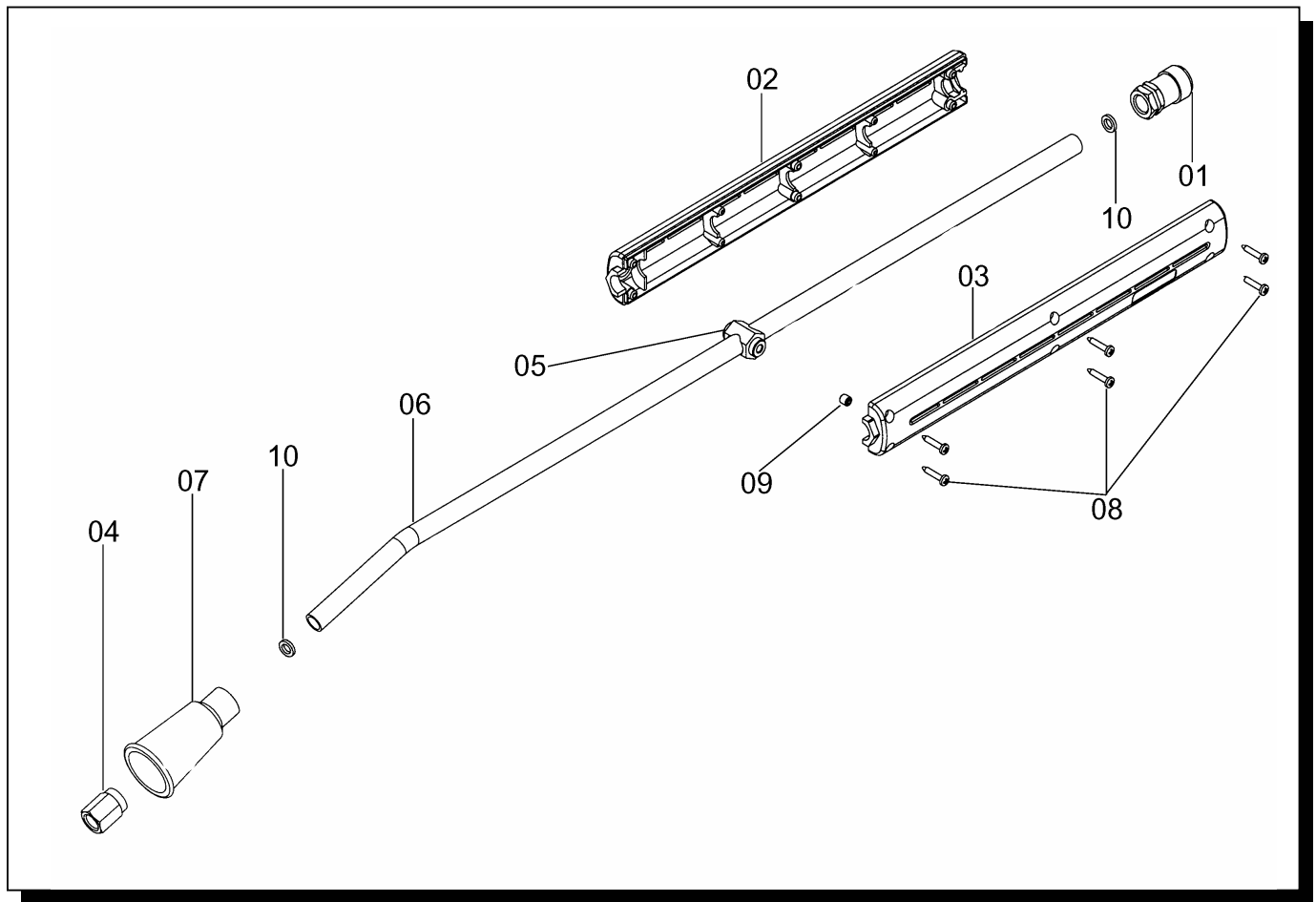

Pos.	Cod.	Descrizione	Description	Descripción	N°
01	1.001.02.046	Raccordo ARF 1/4"G	1/4"G ARF union	Racor ARF 1/4"G	1
02	1.017.02.003	Impugnatura superiore	Upper grip	Empunadura superior	1
03	1.017.02.004	Impugnatura inferiore	Lower grip	Empunadura inferior	1
04	1.019.02.010	Riduzione porta ugello	Nozzleholder reduction gear	Reduccion portatobera	1
05	1.036.02.006	Inserto lancia SC10	Lance insert	Inserto lanza	1
06	1.044.32.005	Tubo inox 13x1,5x700 1/4"G	Inox tube 13x1,5x700 1/4"G	Tubo inox 13x1,5x700 1/4"G	1
07	1.046.02.005	Protezione ugello	Nozze protection	Protección tobera	1
08	4.002.92.001	Vite Autofilettante 3,5x19	Self-tapping screw 3,5x19	Tornillo autoblocante 3,5x19	6
09	4.004.12.001	Vite STEI M6x6 UNI5923-67	STEI M6x6 UNI5923-67 screw	Tornillo STEI M6x6 UNI5923-67	1
10	4.008.12.003	Rondella rame 1/4"G	1/4"G copper washer	Arandola 1/4"G	2

**PREMONTATO IDRO – PREASSEMBLED IDRO –
PREESAMBLADO IDRO**

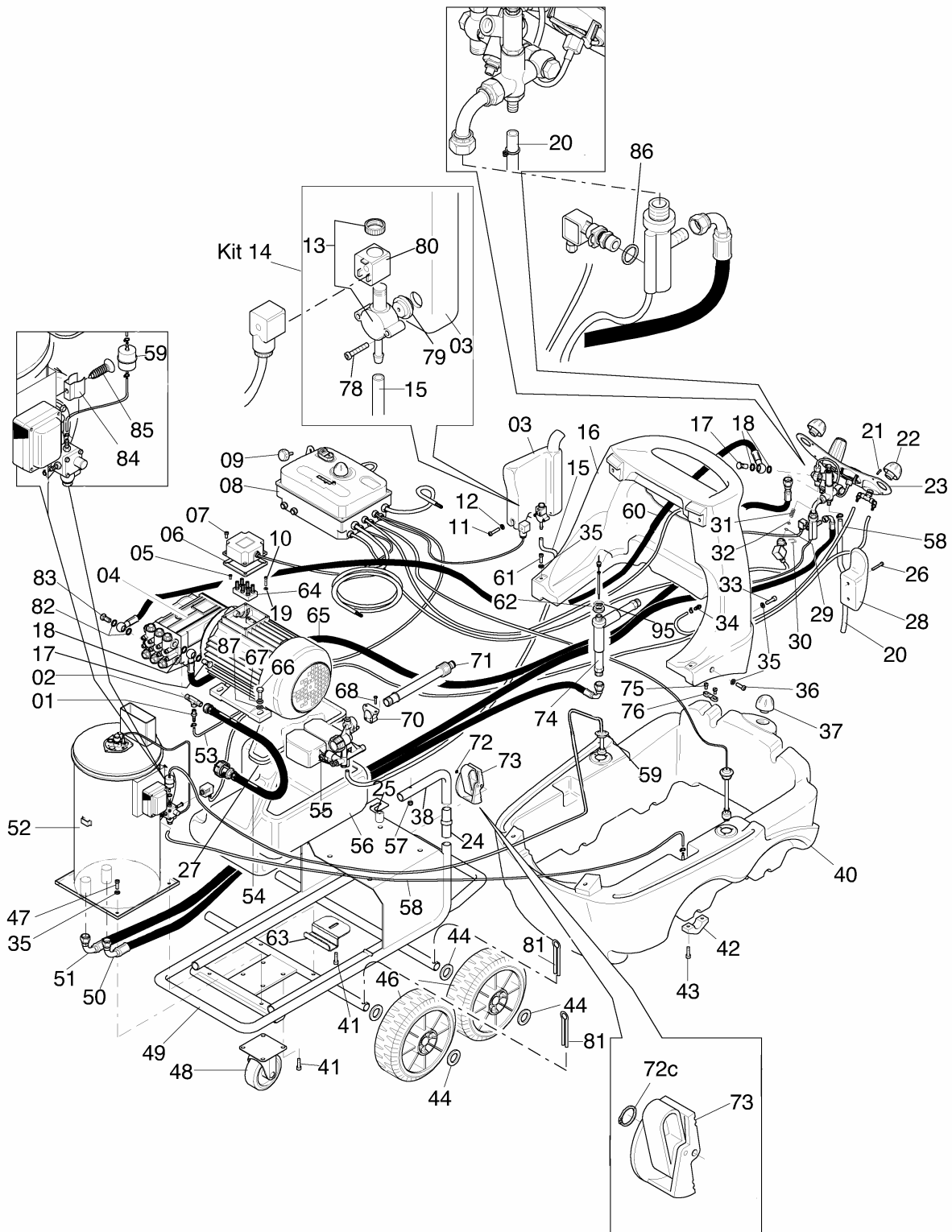

**PREMONTATO IDRO – PREASSEMBLED IDRO –
PREESAMBLADO IDRO**

Pos.	Cod.	Descrizione	<i>Description</i>	<i>Descripción</i>	N°
01	2.033.02.003	Portagomma	Hose fitting	Portamanguera	1
02	1.001.24.003	Raccordo a "T"	"T" connection	Racor "T"	1
03	1.033.04.011	Serbatoio anticalcare	Anti limestone tank	Tanque anti caliza	1
04a	3.006.12.059	Motopompa W4000 "Hawk"	Motorpump W4000 "Hawk"	Motobomba W4000 "Hawk"	1
04b	3.006.12.067	Motopompa W4000 "Interpump"	Motorpump W4000 "Interpump"	Motobomba W4000 "Interpump"	1
04c	3.006.12.062	Motopompa W4050 "Hawk"	Motorpump W4050 "Hawk"	Motobomba W4050 "Hawk"	1
04d	3.006.12.013	Motopompa W4050 "Interpump"	Motorpump W4050 "Interpump"	Motobomba W4050 "Interpump"	1
05	4.002.12.012	Vite M4x14	M4x14 screw	Tornillo M4x14	2
06	1.006.12.003	Guarnizione	Gasket	Empaquadera	1
07	4.002.14.022	Vite M5x10	M5x10 screw	Tornillo M5x10	4
08	2.031.04.066	Quadro elettrico	Switch-board	Panel mandos	1
09	1.021.04.009	Manopola	Knob	Pomo	1
10	4.002.94.016	Vite M3,5x8	M3,5x8 screw	Tornillo M3,5x8	1
11	4.002.12.007	Vite M6x35	M6x35 screw	Tornillo M6x35	1
12	4.008.24.001	Rondella	Washer	Arandela	1
13	4.072.02.001	Elettrovalvola	Electrovalve	Electoválvula	1
14	2.040.04.004	Premontato serbatoio anticalcare	Preassembled anti limestone tank	Preensamblado tanque anti calizia	1
15	1.044.44.033	Tubo anticalcare	Anti limestone tube	Tubo anti caliza	1
16	1.033.04.017	Serbatoio detergente	Detergent tank	Tanque detergente	1
17	1.012.14.003	Tappo 3/8"G	3/8"G plug	Tapa 3/8"G	2
18	4.070.04.001	Rondella 3/8"G	3/8"G washer	Arandela 3/8"G	4
19	4.008.54.001	Rondella SCHNORR	SCHNORR washer	Arandela SCHNORR	1
20	2.074.04.009	Tubo + fascetta	Tube + clamp	Tubo + faja	1
21	4.002.22.001	Vite M4x10	M4x10 screw	Tornillo M4x10	4
22	2.013.04.007	Tappo serbatoio	Tank plug	Tapa tanque	2
23	2.058.04.001	Pannello comandi	Console	Panel de mando	1
24	1.002.24.004	Perno	Pivot	Gozne	1
25	4.047.04.007	Insero M10	M10 insert	Insero M10	4
26	4.002.12.008	Vite M6x25	M6x25 screw	Tornillo M6x25	4
27	1.054.04.035	Coperchio serbatoio acqua	Water tank cover	Tapa tanque agua	1
28	1.126.04.001	Gancio universale	Universal hook	Gancho universal	2
29	4.005.22.003	OR pressostato	Pressure gauge O-Ring	OR presostato	1
30	1.081.02.001	Forcella pressostato	Pressure gauge fork	Horquilla presostato	1
31	1.025.12.010	Molla pressostato	Pressure gauge spring	Muelle presostato	1
32	4.008.02.002	Rondella pressostato	Pressure gauge washer	Arandela presostato	1
33	4.002.12.009	Vite M8x35	M8x35 screw	Tornillo M8x35	2
34	2.033.02.002	Portagomma	Hose fitting	Portamanguera	1
35	4.008.24.002	Rondella	Washer	Arandela	9
36	4.002.12.004	Vite M8x30	M8x30 screw	Tornillo M8x30	2
37	2.013.04.013	Tappo serbatoio gasolio	Gas oil tank plug	Tapa tanque gasoleo	1
38	2.064.04.001	Supporto quadro elettrico	Electric pannel support	Soporte tablero eléctrico	1
39					
40	1.033.04.018	Serbatoio gasolio	Gas oil tank	Taque gasoleo	1
41	4.002.14.014	Vite M8x16	M8x16 screw	Tornillo M8x16	5
42	1.089.04.023	Staffa fissaggio telaio	Frame fixing bracket	Estribo fijación estructura	4
43	4.002.14.026	Vite M8x18	M8x18 screw	Tornillo M8x18	8
44	1.003.04.006	Rondella	Washer	Arandela	8

**PREMONTATO IDRO – PREASSEMBLED IDRO –
PREESAMBLADO IDRO**

Pos.	Cod.	Descrizione	<i>Description</i>	<i>Descripción</i>	N°
45	4.008.12.003	Rondella rame 1/4"G	1/4"G copper washer	Arandela 1/4"G	1
46	1.086.04.016	Ruota	Wheel	Rueda	4
47	4.002.11.002	Vite M8x25	M8x25 screw	Tornillo M8x25	3
48	1.086.04.004	Ruota girevole	Revolving wheel	Rueda giratoria	1
49	2.015.04.007	Telaio	Frame	Estruttura	1
50	2.006.04.022	Tubo mandata caldaia	Boiler intake tube	Tubo envío caldera	1
51	2.006.04.023	Tubo uscita caldaia	Boiler out tube	Tubo uscita caldera	1
52	3.026.04.016	Caldaia	Boiler	Caldera	1
53	2.074.04.030	Tubo aspirazione detergente	Detergent suction tube	Tubo de aspiración detergente	1
54	2.059.04.001	Pescante	Draft device	Sonda de aspiración	1
55	2.057.04.001	Galleggiante con filtro	Float with filter	Flotadores con filtro	1
56	1.100.04.004	Serbatoio acqua	Water tank	Tanque agua	1
57	4.009.14.002	Dado autobloccante	Self-locking nut	Tuerca autobloqueante	1
58	2.074.04.010	Tubo vitrex L450	Vitrex tube L450	Tubo vitrex L450	2
59	2.074.04.026	Tubo gasolio	Gas oil tube	Tubo gasoleo	1
60	2.006.04.025	Tubo by-pass	By-pass tube	Tubo by-pass	1
61	4.002.14.019	Vite M8x55	M8x55 screw	Tornillo M8x55	2
62	1.015.24.002	Ghiera	Ring nut	Tuerca	1
63	1.089.04.040	Staffa serbatoio acqua	Water tank stirrup	Estribo tanque agua	1
64	4.033.02.005	Morsettiera	Junction box	Terminal de conexión	1
65	2.006.04.021	Tubo	Tube	Tubo	1
66	4.002.44.006	Vite M10x40	M10x40 screw	Tornillo M10x40	4
67	4.008.04.004	Rondella	Washer	Arandela	4
68	4.002.24.003	Vite M6x16	Mx16 screw	Arandela M6x16	2
69					
70	1.011.04.027	Supporto tubo aspirazione	Suction tube support	Soporte tubo de aspiración	1
71	2.063.04.001	Tubo aspirazione	Suction tube	Soporte tubo	1
72	4.025.04.009	Seeger esterno	External seeger	Seeger esterno	1
73	2.052.04.002	Freno	Brake	Freno	1
74	2.048.04.004	Collettore	Manifold	Colector	1
75	4.002.72.002	Vite M4x10	M4x10 screw	Tornillo M4x10	2
76	1.045.04.003	Pressacavo	Cable gland	Prensacable	1
77					
78	4.002.14.013	Vite M4x30	M4x30 screw	Tornillo M4x30	2
79	1.006.14.006	Guarnizione serbatoio	Tank gasket	Empaquetadura tanque	1
80	4.040.02.002	Bobina	Spool	Bobina	1
81	4.044.04.004	Copiglia	Pin	Espina	4
82	4.070.04.002	Rondella 1/2"G	1/2"G washer	Arandela 1/2"G	2
83	1.012.14.004	Tappo 1/2"G	1/2"G plug	Tapa 1/2G	1
84	1.011.02.003	Portafiltro	Filter-holder	Portafiltro	1
85	4.002.94.015	Vite autofilettante 3,9x9,5	3,9x9,5 self-tapping screw	Tornillo autoblocante 3,9x9,5	1
86	4.008.12.002	Rondella rame 13x19x1,5	13x19x1,5 copper washer	Arandela 13x19x1,5	1
87	4.008.54.003	Rondella GROWER	GROWER kasher	Arandela GROWER	4

PREMONTATO CALDAIA – PREASSEMBLED BOILER – PREENSAMBLADO CALDERA

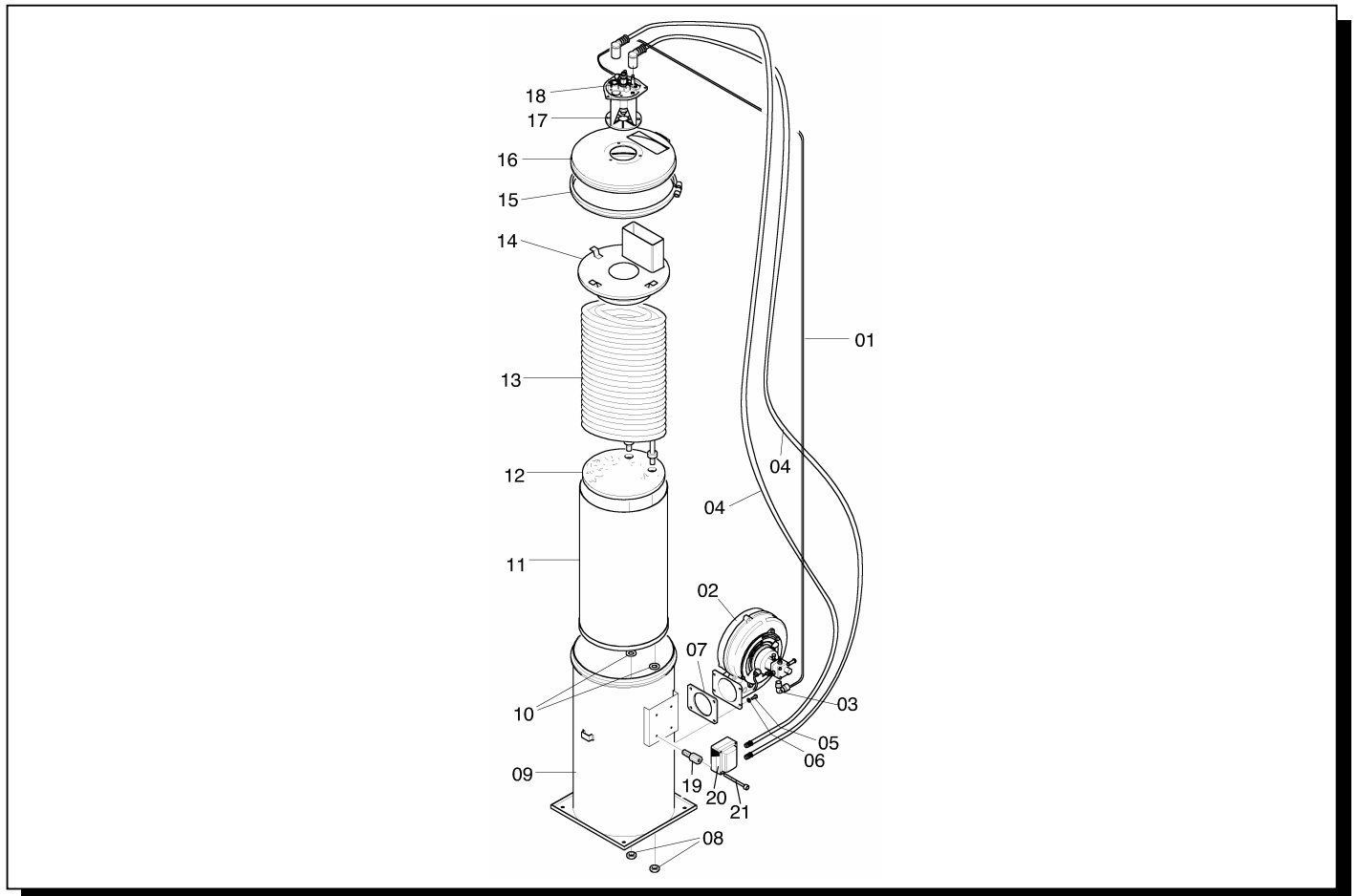

Pos.	Cod.	Descrizione	Description	Descripción	N°
01	1.044.54.003	Tubo rame gasolio	Gas oil copper tube	Tubo gasoleo	1
02	3.038.02.003	Convogliatore	Conveyor	Transportador	1
03	3.050.14.001	Raccordo tubo gasolio	Gas oil tube connection	Racor tubo gasoleo	1
04	2.020.04.012	Cavo trasformatore	Transformer wire	Cable transformador	2
05	4.002.44.001	Vite M6x20	M6x20 screw	Tornillo M6x20	2
06	4.008.24.001	Rondella	Washer	Arandela	2
07	1.006.04.001	Guarnizione	Gasket	Empaquetadura	1
08	1.015.24.002	Ghiera	Ring nut	Abrazadera	2
09	2.023.04.013	Camicia esterna	External jacket	Camisa esterna	1
10	1.060.04.018	Distanziale 6mm	6mm spacer	Distanciador 6mm	2
11	2.023.04.010	Camicia interna	Internal jacket	Camisa interior	1
12	1.094.04.005	Isolante	Insulator	Aislante	1
13	2.029.04.008	Serpentina	Warming	Serpent	1
14	2.012.04.013	Camino	Chimney	Chimenea	1
15	2.056.04.001	Fascetta	Clamp	Faja	1
16	1.054.04.006	Coperchio	Cover	Tapa	1
17	2.012.04.020	Premontato elettrodi	Preassembled Electrodes	Preensamblado electrodos	1
18	4.002.94.017	Vite autofilettante 3,9x13	3,9x13 self-tapping screw	Tornillo autobloccante 3,9x13	3
19	1.011.04.013	Supporto trasformatore	Transformer support	Soporte transformador	2
20	4.030.04.001	Trasformatore	Transformer	Transformador	1
21	4.002.14.009	Vite M4x50	M4x50 screw	Tornillo M4x50	2

PREMONTATO CONVOGLIATORE – PREASSEMBLED CONVEYOR – PREESAMBLADO TRANSPORTADOR

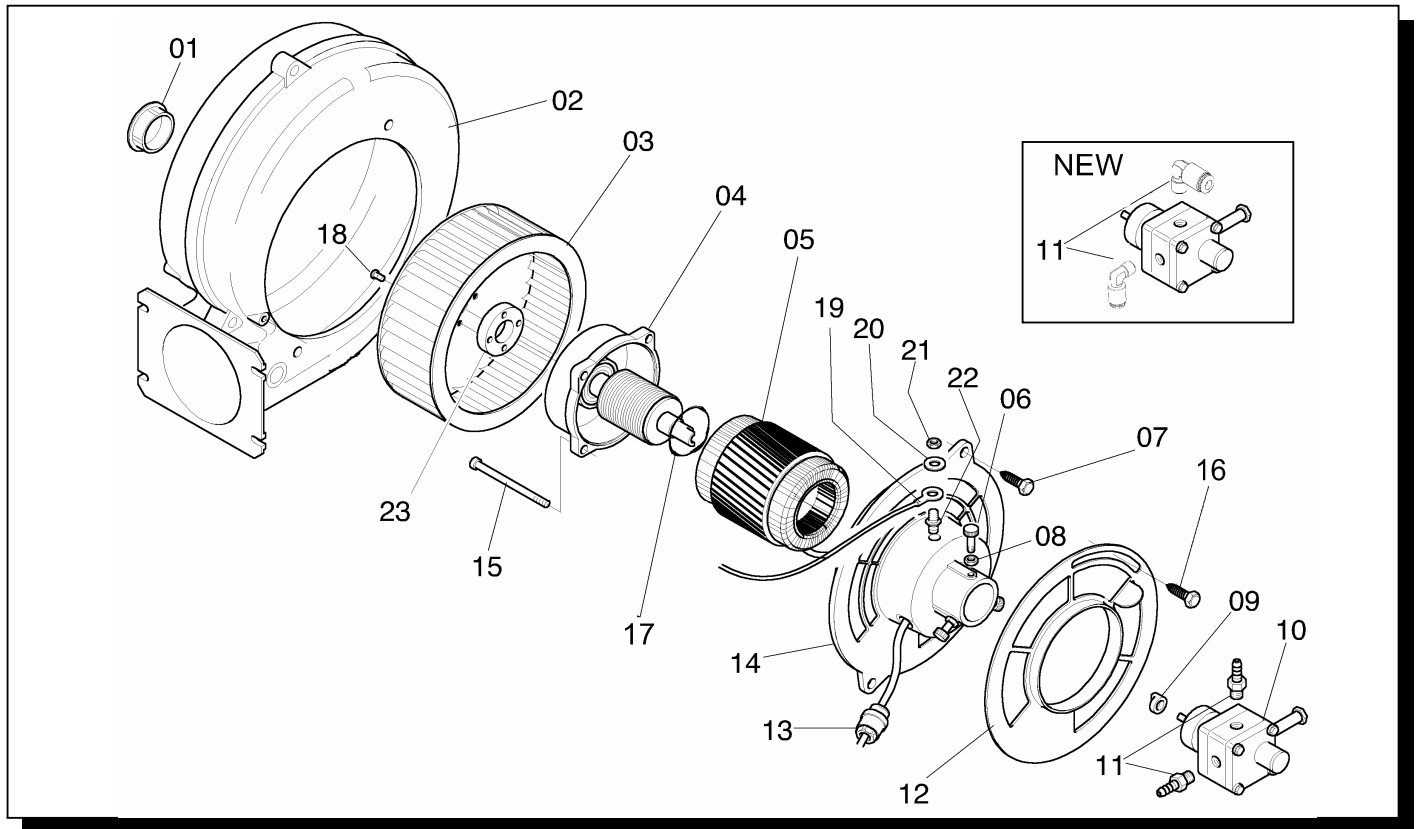

Pos.	Cod.	Descrizione	Description	Descripción	N°
01	4.036.02.002	Tappo	Plug	Tapa	1
02	2.017.02.001	Carter convogliatore	Conveyor guard	Cartér transportador	1
03	1.073.02.006	Ventola	Fan	Ventilador	1
04	2.014.02.030	Albero + rotore	Shaft + rotor	Eje + rotor	1
05	2.025.22.001	Statore	Stator	Estátor	1
06	1.004.04.001	Vite M5x20	M5x20 screw	Tornillo M5x20	3
07	4.002.92.007	Vite autofilettante 6,3x16	6,3x16 self-tapping screw	Tornillo autobloccante 6,3x16	2
08	4.009.02.001	Dado M5	M5 nut	Tuerca M5	3
09	1.098.02.001	Giunto	Coupling	Junta	1
10	3.015.24.007	Pompa gasolio	Gas oil pump	Bomba gasoleo	1
11a	2.033.02.002	Portagomma	Hose-fitting	Portamanguera	2
11b	2.012.04.013	Raccordo	Connection	Racor	2
12	1.009.02.004	Griglia controllo aria	Air check grate	Rejilla de control aire	1
13	2.027.02.004	Pressacavo	Cable clamping device	Prensacable	1
14	1.074.02.025	Flangia	Flange	Brida	1
15	4.002.12.016	Vite M4x45	M4x45 screw	Tornillo M4x45	4
16	4.002.94.012	Vite flangiata	Flanged screw	Tornillo con brida	2
17	4.049.12.005	Anello di compensazione			1
18	4.002.72.004	Vite M3x6	M3x6 screw	Tornillo M3x6	4
19	2.020.14.088	Cavo di terra	Ground wire	Cable de tierra	1
20	4.008.52.002	Rondella	Washer	Arandela	1
21	4.009.04.003	Dado M8	M8 nut	Tuerca M8	1
22	1.004.22.002	Vite messa a terra	Ground screw	Tornillo de tierra	1
23	1.060.02.006	Distanziale W5050	Spacer W5050	Distanciador W5050	1

COPERCHIO PORTA ELETTRODI – ELECTRODES HOLDER – TAPA PORTAELECTRODOS

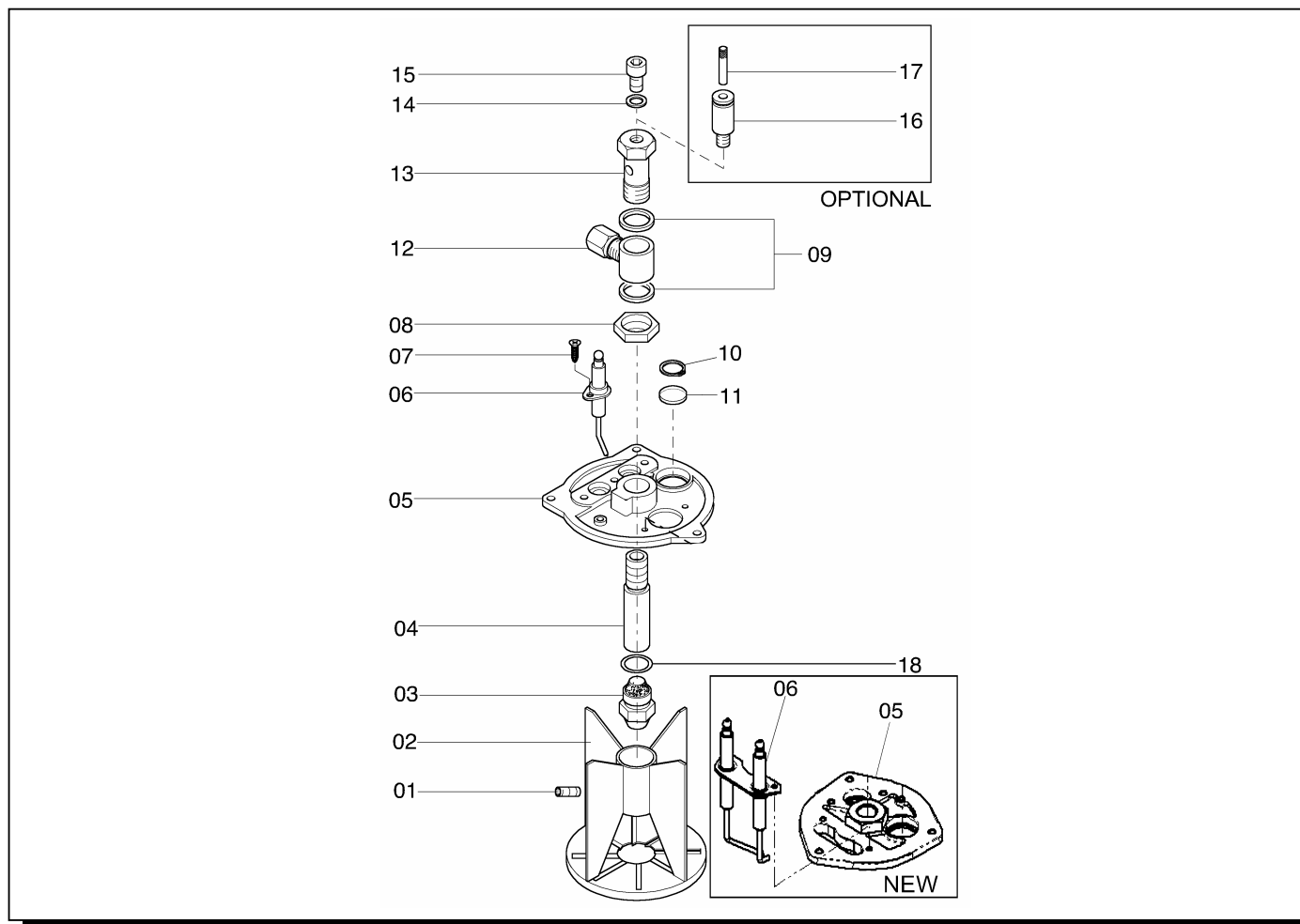

Pos.	Cod.	Descrizione	Description	Descripción	N°
01	4.004.34.001	Grano	Grub nut	Grano	1
02	2.009.04.002	Deflettore	Deflector	Deflector	1
03	4.027.14.015	Ugello	Nozzle	Tobera	1
04	1.001.04.006	Raccordo porta ugello	Nozzle holder	Racor porta tobera	1
05a	1.074.04.003	Flangia elettrodo singolo	Single electrode flange	Brida elettrodo singolo	1
05b	1.074.04.011	Flangia doppio elettrodo	Double electrodes flange	Brida dos electrodos	1
06a	2.032.04.003	Elettrodo	Electrode	Elettrodo	2
06b	2.032.04.004	Doppio elettrodo	Double electrodes	Elettrodos doppio	1
07	4.002.94.005	Vite autofilettante M3,9x13	M3,9x13 self-tapping screw	Tornillo autobloccante M3,9x13	2
08	1.015.24.003	Ghiera	Ring nut	Abrazadera	1
09	4.008.12.005	Rondella rame	Copper washer	Arandela	2
10	4.025.04.002	Seeger	Seeger	Seeger	1
11	1.102.04.001	Vetrino	Glass	Vidrio	1
12	3.050.34.001	Raccordo	Connection	Racor	1
13	1.012.14.012	Tappo	Plug	Tapa	1
14	4.008.14.003	Rondella rame	Copper washer	Arandela	2
15	4.002.14.022	Vite M5x10	M5x10 screw	Tornillo M5x10	1
16	4.012.04.006	Raccordo controllo pressione	Pressure control union	Conector rápido	1
17	4.036.04.007	Tappo	Plug	Tapa	1
18	4.005.14.004	OR	O-Ring	OR	1

**PREMONTATO GALLEGGIANTE CON FILTRO – PREASSEMBLED
FLOAT WITH FILTER – PREENSAMBLADO FLOTADOR CON FILTRO**

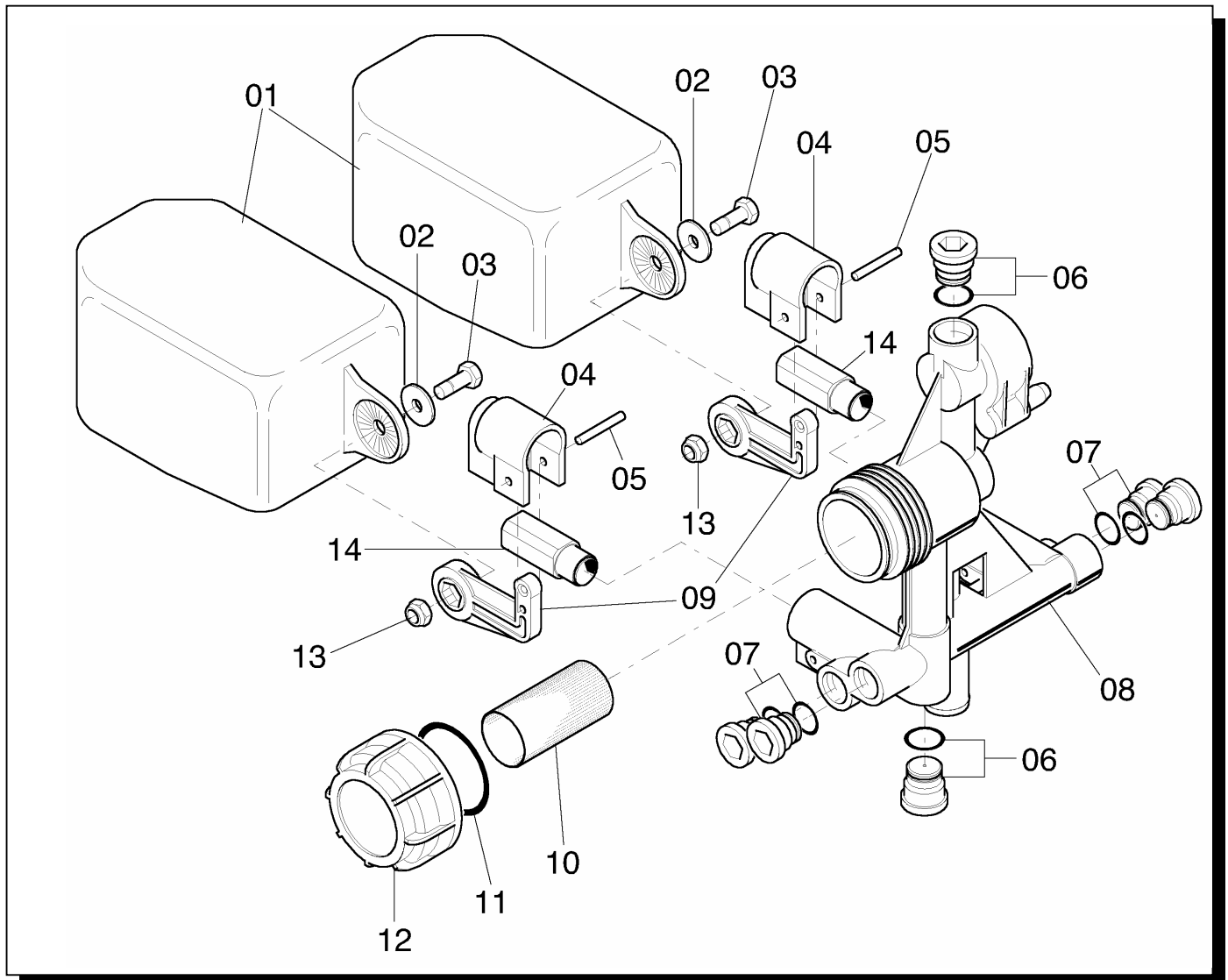

Pos.	Cod.	Descrizione	Description	Descripción	N°
01	1.103.04.001	Galleggiante	Float	Flotador	2
02	4.008.04.003	Rondella	Washer	Arandola	2
03	4.002.44.003	Vite	Screw	Tornillo	2
04	1.112.04.002	Calotta per galleggiante con freno	Float cap with brake	Tapa para flotador con freno	2
05	1.013.14.002	Spina cilindrica	Cylindrical pin	Vástago cilindrico	2
06	2.013.04.016	Tappo 3/8" G	3/8" G plug	Tapa 3/8" G	2
07	2.013.04.015	Tappo 1/4" G	1/4" G plug	Tapa 1/4" G	4
08	2.048.04.009	Collettore	Manifold	Colector	1
09	1.016.04.002	Leva per galleggiante	Float pivot	Palanca para flotador	2
10	1.030.04.003	Filtro a rete	Net filter	Filtro de red	1
11	4.005.31.015	OR 3131	O-Ring 3131	OR3131	1
12	1.012.04.007	Tappo porta filtro	Filter plug	Tapòn portafiltro	1
13	4.009.12.002	Dado esagonale	Hexagonal nut	Turca hexagonal	2
14	2.002.04.002	Otturatore galleggiante	Float shutter	Obturador flotador	2
15	1.006.14.003	Guarnizione	Basket	Empaquetadura	1

TUBO ASPIRAZIONE – SUCTION TUBE – TUBO DE ASPIRACIÓN

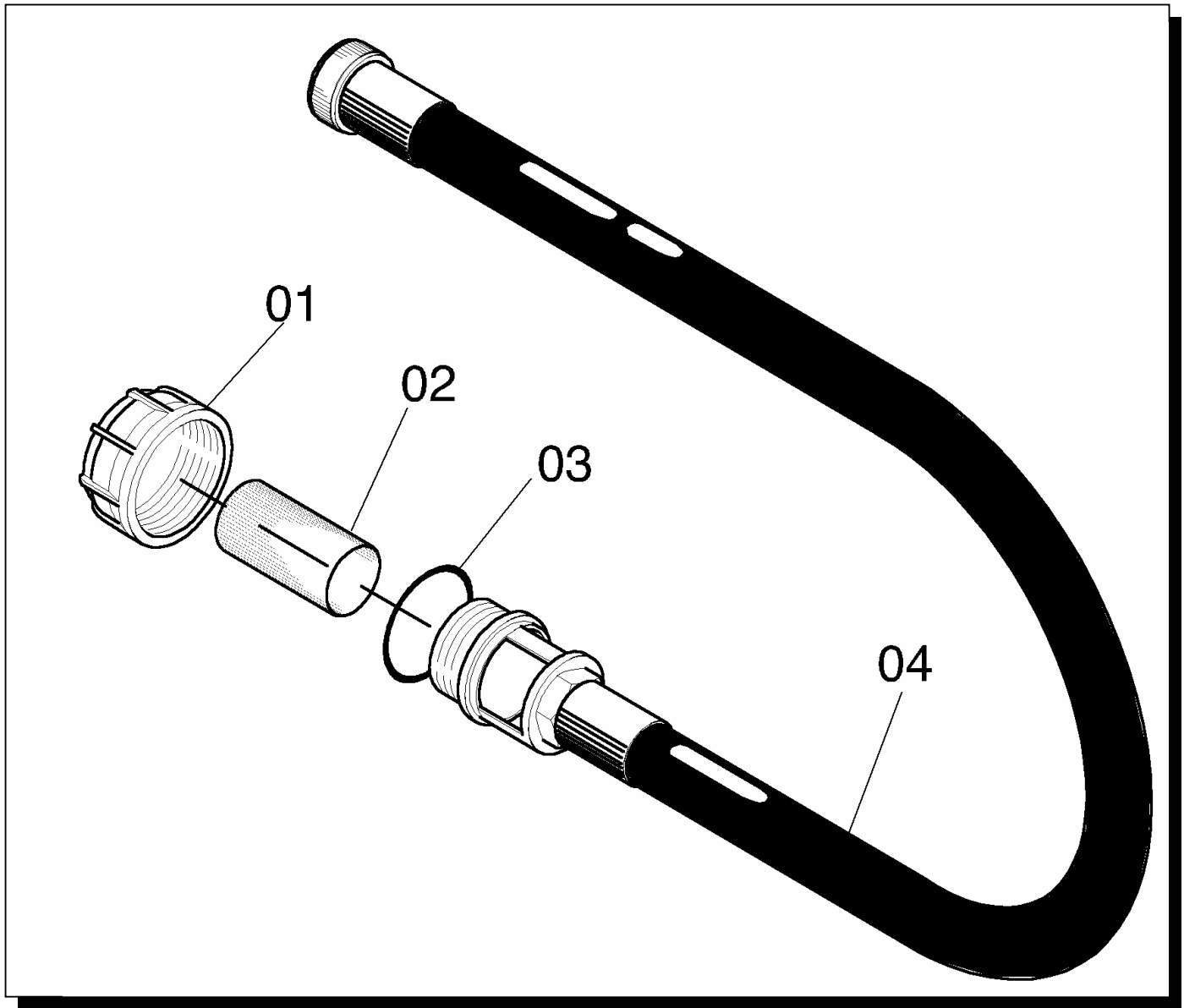

Pos.	Cod.	Descrizione	Description	Descripción	N°
01	1.012.04.007	Tappo	Plug	Tapón	1
02	1.030.04.003	Filtro	Filter	Filtro	1
03	4.005.31.015	Guarnizione	Gasket	Empaquetadura	1
04	2.074.04.002	Tubo	Tube	Tubo	1
05	4.005.21.018	Guarnizione	Gasket	Empaquetadura	1
06	4.005.21.003	Guarnizione	Gasket	Empaquetadura	1

PREMONTATO PANNELLO COMANDI – PREEASSEMBLED CONTROL PANEL – PREENSAMBLADO PANEL MANDOS

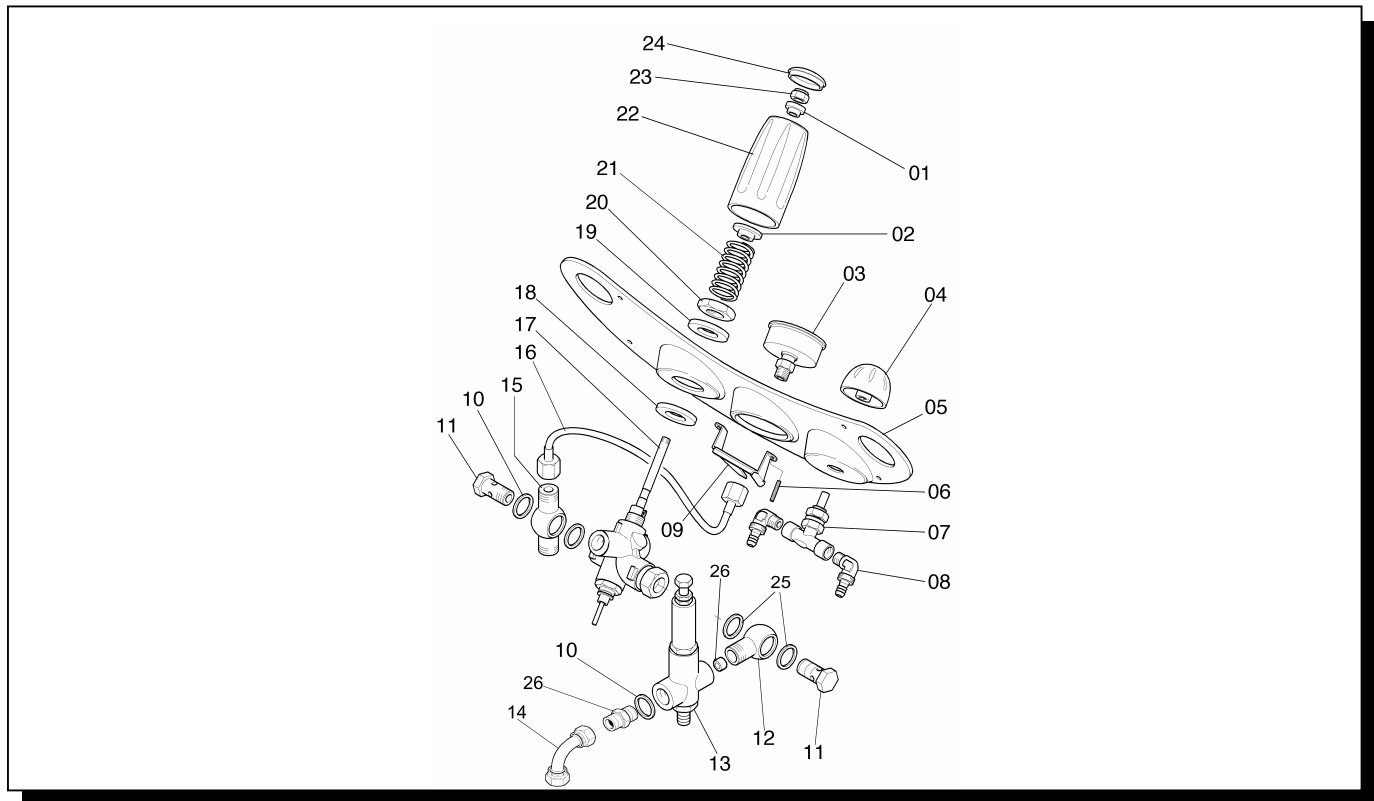

Pos.	Cod.	Descrizione	Description	Descripción	N°
01	1.036.02.001	Inserto manopola	Knob insert	Inserción pomo	1
02	1.072.02.004	Premimolla valvola	Valve springpress	Sejeta-resorte válvula	1
03	4.020.14.002	Manometro	Pressure gauge	Manómetro	1
04	1.021.04.008	Manopola detergente	Detergent knob	Pomo detergente	1
05	1.111.04.002	Pannello comandi	Control panel	Panel mandos	1
06	4.004.32.002	Grano	Grub screw	Grano	2
07	3.003.34.001	Valvola detergente	Detergent valve	Válvula detergente	1
08	1.049.04.003	Portagomma	Hose-fitting	Portamanguera	2
09	1.089.04.003	Staffa manometro	Pressure gauge bracket	Brida manómetro	1
10	4.070.04.001	Rondella	Washer	Arandela	3
11	1.012.14.003	Tappo	Plug	Tapa	2
12	1.001.34.015	Occhiello	Eyelet	Argolla	1
13	3.003.22.002	Valvola di sicurezza	Safety valve	Válvula de seguridad	1
14	4.012.04.009	Raccordo	Connection	Racor	1
15	1.001.34.005	Occhiello doppio	Double eyelet	Argolla doppio	1
16	2.006.24.006	Tubo manometro	Pressure gauge tube	Tubo manómetro	1
17	2.003.34.005	Valvola VRB	VRB valve	Válvula VRB	1
18	1.003.04.007	Rondella inferiore VRB	VRB lower washer	Arndela inferior VRB	1
19	1.003.04.008	Rondella superiore VRB	VRB upper washer	Arandela superior VRB	1
20	1.015.02.019	Ghiera	Ring nut	Abrazadera	1
21	1.025.22.001	Molla blu	Blue spring	Muelle azul	1
22	1.021.02.012	Manopola VRB	VRB knob	Pomo VRB	1
23	4.009.12.001	Dado	Nut	Tuerca	1
24	1.012.02.005	Tappo manopola	Knob plug	Tapón pomo	1
25	4.008.12.001	Rondella rame	Copper washer	Arandela	2
26	1.006.22.001	Guarnizione	Gasket	Empaquetadura	1
27	1.096.04.001	Nipple 3/8"G	Nipple 3/8"G	Nipple 3/8"G	1

VALVOLA SICUREZZA – SAFETY VALVE – VÁLVULA DE SEGURIDAD

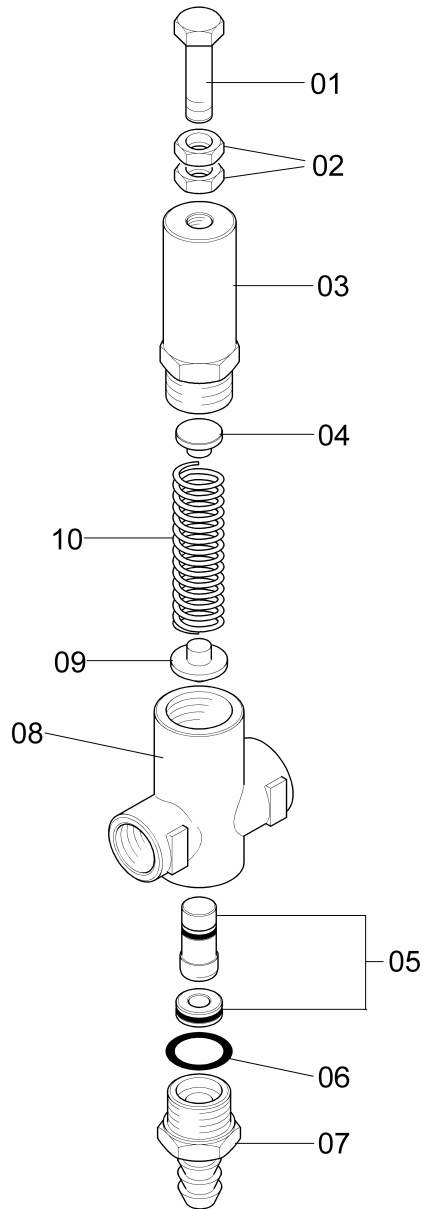

Pos.	Cod.	Descrizione	Description	Descripción	N°
01	4.002.42.003	Vite M8x30	M8x30 screw	Tornillo M8x30	1
02	4.009.04.003	Dado M8	M8 nut	Tuerca M8	2
03	1.021.02.011	Manopola	Grip	Pomo	1
04	1.072.02.011	Premimolla superiore	Upper spring device	Sujeta-resorte superior	1
05	9.005.02.004	Kit ricambio otturatore	Shutter spare kit	Kit repuestos obturador	1
06	4.005.21.011	Guarnizione	Gasket	Empaquetadura	1
07	1.049.02.007	Portagomma	Tube holder	Portagoma	1
08	1.020.22.014	Corpo valvola di sicurezza	Safety valve body	Cuerpo válvula de seguridad	1
09	1.072.02.012	Premimolla inferiore	Lower spring device	Sujeta-resorte inferior	1
10	1.025.22.007	Molla valvola di sicurezza	Safety valve spring	Muelle válvula de seguridad	1

VALVOLA BY-PASS – BY-PASS VALVE – VÁLVULA BY-PASS

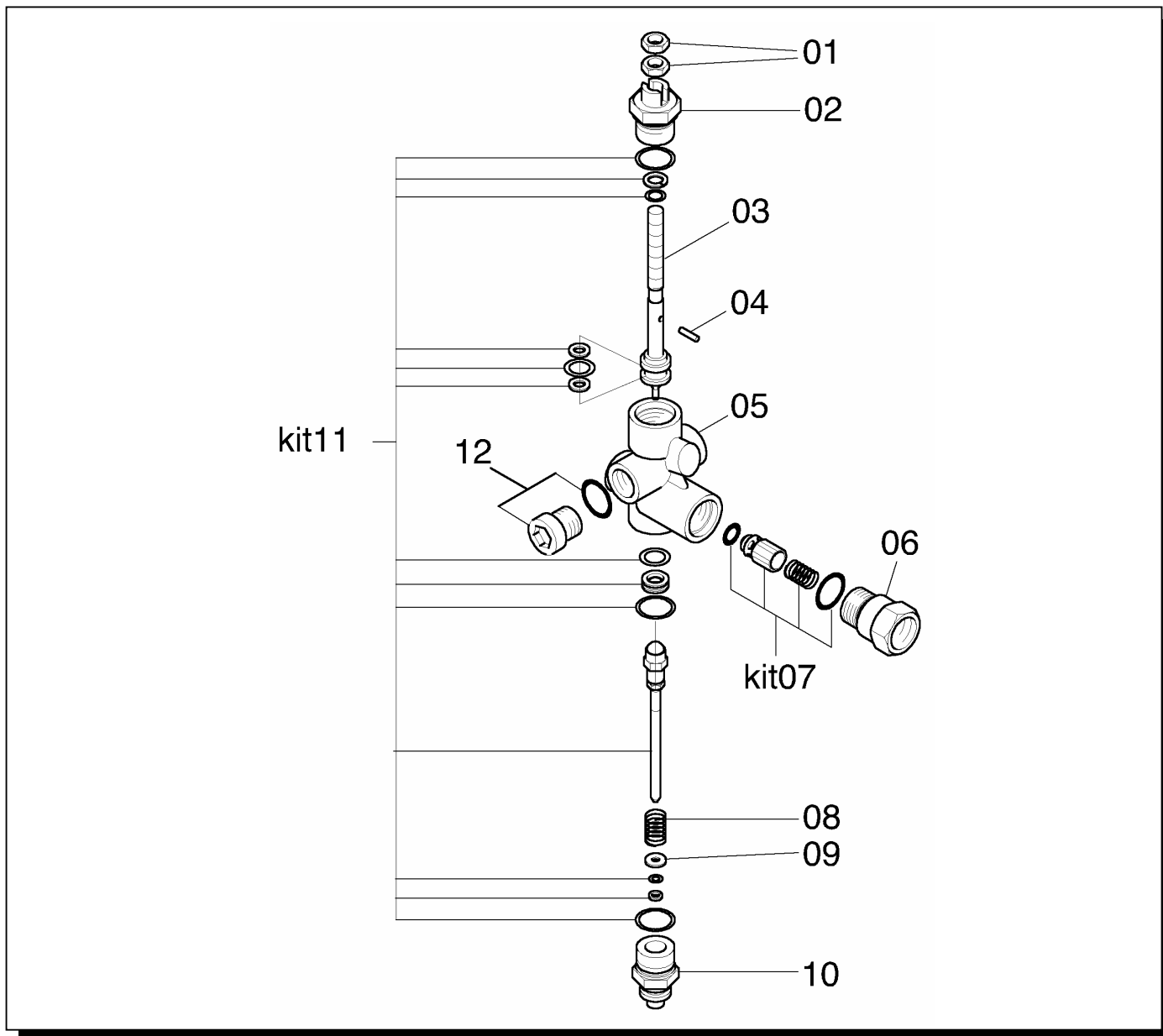

Pos.	Cod.	Descrizione	Description	Descripción	N°
01	1.035.02.001	Dado massima pressione	Max pressure nut	Tuerca maxima presión	2
02	1.001.02.002	Raccordo guida stelo	Stem guide connection	Racor guia de vastago	1
03	1.037.02.001	Stelo VRB	VRB stem	Vastago VRB	1
04	4.011.12.001	Spina elastica	Elastic pin	Espina elástico	1
05	1.020.22.020	Corpo VRB	VRB body	Cuerpo VRB	1
06	1.001.02.003	Raccordo mandata	Delivery connection	Conexión envío	1
07	9.005.02.001	Otturatore mandata	Outlet shutter	Obturador	1
08	1.025.12.002	Molla	Spring	Muelle	1
09	1.003.02.004	Rondella	Washer	Arandela	1
10	1.001.02.024	Raccordo pressostato	Pressure gauge connection	Racor presostato	1
11	9.003.02.007	Kit tenuta Totalstop	Totalstop spare seals kit	Kit cerres Totalstop	
12	2.013.04.016	Tappo	Plug	Tapa	1

PREMONTATO QUADRO ELETTRICO – PREEASSEMBLED SWITCHBOARD – PREENSAMBLADO PANEL MANDOS

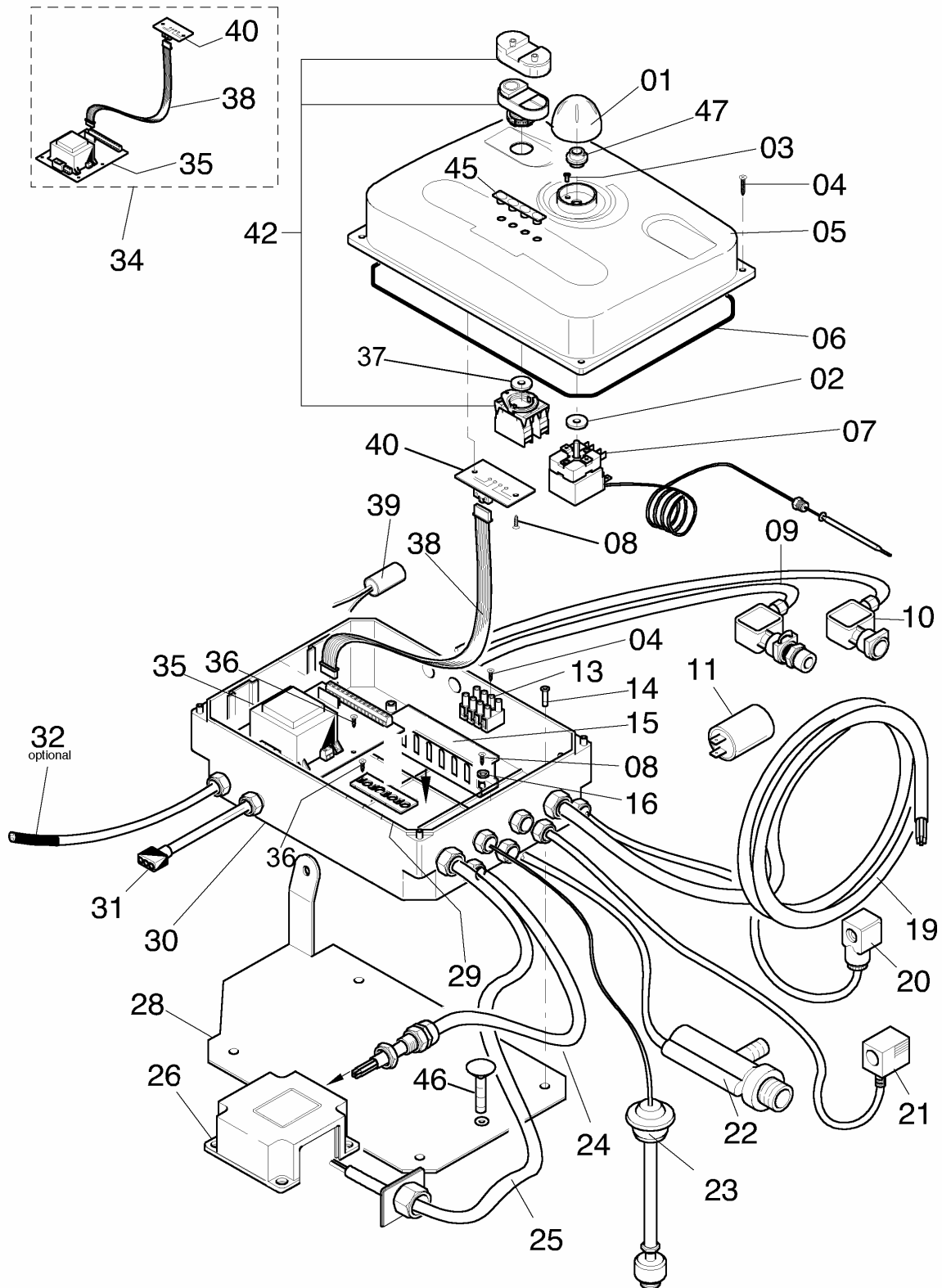

PREMONTATO QUADRO ELETTRICO – PREEASSEMBLED SWITCHBOARD – PREENSAMBLADO PANEL MANDOS

Pos.	Cod.	Descrizione	Description	Descripción	N°
01	1.021.04.006	Manopola	Hand grip	Pomo	1
02	1.006.14.012	Guarnizione interruttore rotativo	Revolving switch gasket	Empaquetadura interruptor	1
47	1.006.14.001	Guarnizione manopola	Hand grip gasket	Empaquetadura pomo	1
03	4.002.22.001	Vite M4x10	M4x10 screw	Tornillo M4x10	2
04	4.002.92.001	Vite autofilettante 3,5x19	3,5x19 self tapping screw	Tornillo autobloccante 3,5x19	6
05	1.054.04.022	Coperchio quadro elettrico	Switchboard cover	Tapa panel mandos	1
06	1.006.14.004	Guarnizione	Gasket	Empaquetadura	1
07	4.031.04.003	Termostato	Thermostat	Termostato	1
08	4.002.94.015	Vite autofilettante 3,9x9,5	3,9x9,5 self tapping screw	Tornillo autobloccante 3,9x9,5	4
09	3.013.04.002	Pressostato	Pressare gauge	Presostato	1
10	2.008.04.001	Pressostato	Pressure gauge	Presostato	1
11	4.035.04.002	Condensatore	Condenser	Condensador	1
13	4.003.04.031	Morsetti	Junction box	Terminal de conexión	1
14	4.002.18.006	Vite M6x8	M6x8 crew	Tornillo M6x8	4
15	1.110.04.001	Canala cablata	Wired raceway	Canal cableado	1
16	4.008.02.001	Rondella	Washer	Arandela	2
26	2.019.02.003	Copribasetta			1
19	2.020.04.043	Cavo elettrico	Elettric wire	Cable eléctrico	1
20	2.080.04.004	Connettore anticalcare	Anti-limestone connector	Conector anticalizia	1
21	2.083.04.001	Bobina gasolio	Gas oil spool	Bobina gasoleo	1
22	2.086.04.002	Flussostato	Flow switch	Flusostato	1
23	3.030.02.006	Livellostato	Leveller	Nivelador	1
25	2.020.04.041	Cavo elettrico	Elettric wire	Cable eléctrico	1
24	2.020.04.044	Cavo termico	Termal cable	Cable termico	1
46	4.002.04.005	Vite M10x55	M10x55 screw	Tornillo M10x55	1
38	2.020.32.002	Cavo piatto	Multiwire	Connexión electrica multipla	1
28	1.011.04.029	Supporto quadro elettrico	Switchboard support	Soporte panel mandos	1
29	1.128.04.003	Barra messa a terra	Ground bar	Barra de tierra	1
30	1.078.04.017	Scatola elettrica	Electric box	Caja eléctrica	1
31	2.020.04.030	Cavo trasformatore	Transformer wire	Cable transformador	1
32	2.082.04.002	Sonda controllo fiamma	Flame control probe	Sonda control de flama	1
33	1.015.32.008	Ghiera	Ring nut	Abrazadera	1
35	3.024.02.020	Scheda MCC10	MCC10 card	Ficha MCC10	1
54	4.002.092.003	Vite autofilettante 3,5x10	3,5x10 self tapping screw	Tornillo autobloccante 3,5x10	2
37	4.005.22.025	OR 3075	O-Ring 3075	OR 3075	1
39	1.030.04.004	Filtro capacitivo	Capacitive filter	Filtro con capacidad	1
40	3.024.02.019	Scheda LED	LED card	Ficha LED	1
42	4.018.04.008	Interruttore	Switch	Interruptor	1
45	1.102.04.002	Vetro spia	Spy glass	Cristal para indicados	1
34	9.021.04.001	Kit ricambio scheda MCC10	MCC10 card spare kit	Kit repuestos ficha MCC10	1

COMPLESSIVO MOTOPOMPA – MOTORPUMP LAYOUT – ESQUEMA GENERAL MOTOBOMBA

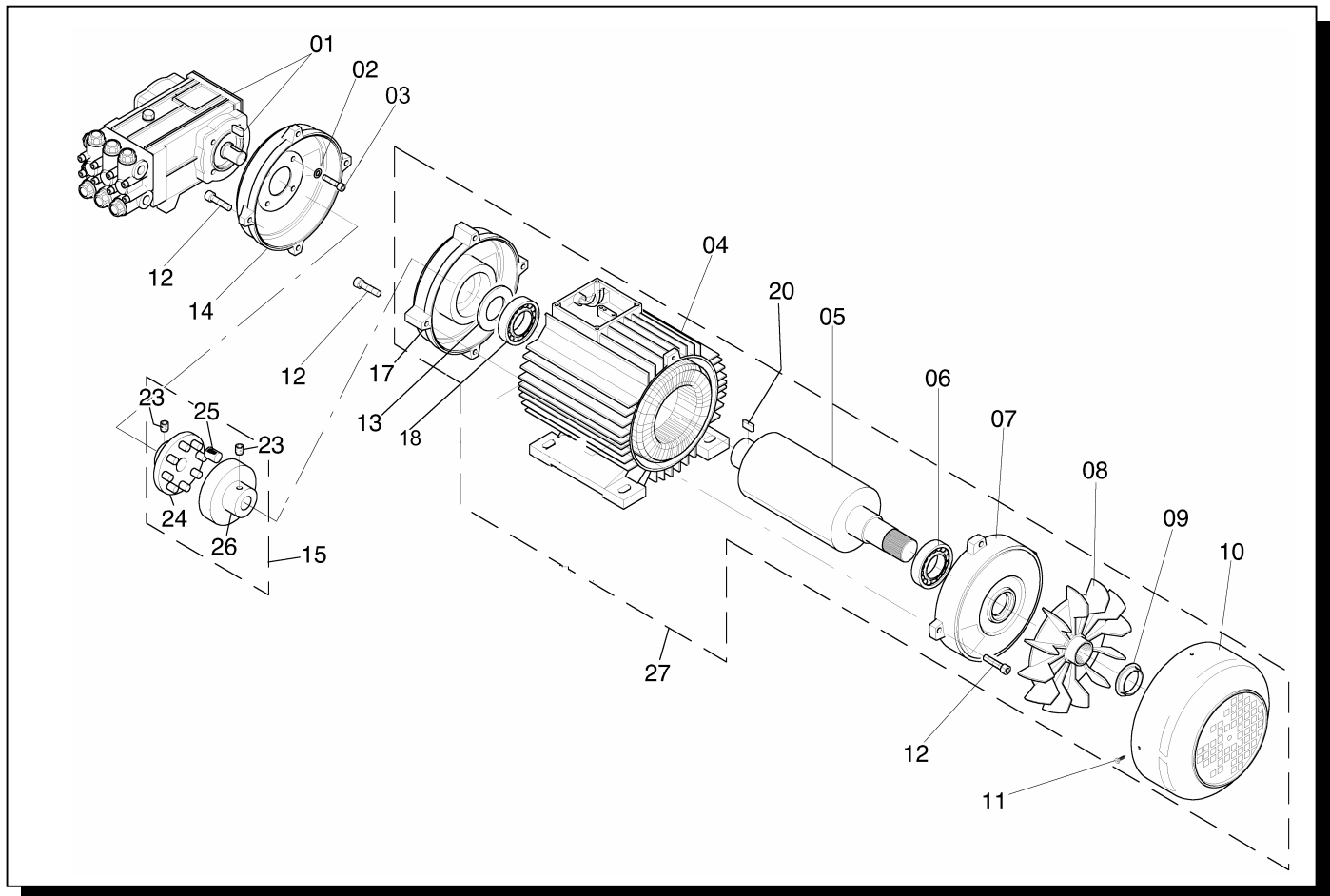

Pos.	Cod.	Descrizione	Description	Descripción	N°
01a	3.015.12.043	Motopompa W4000 "Hawk"	Motorpump W4000 "Hawk"	Motobomba W4000 "Hawk"	1
01b	3.015.12.062	Motopompa W4050 "Hawk"	Motorpump W4050 "Hawk"	Motobomba W4050 "Hawk"	1
01c	3.015.12.067	Motopompa W4000 "Interpump"	Motorpump W4000 "Interpump"	Motobomba W4000 "Interpump"	1
01d	3.015.12.013	Motopompa W4050 "Interpump"	Motorpump W4050 "Interpump"	Motobomba W4050 "Interpump"	1
02	4.008.52.002	Rondella	Washer	Arandela	4
03a	4.002.11.002	Vite M8x25 "Hawk"	M8x25 screw "Hawk"	Tornillo M8x25 "Hawk"	4
03b	4.002.11.004	Vite M8x30 "Interpump"	M8x30 screw "Interpump"	Tornillo M8x30 "Interpump"	4
04	2.017.02.023	Premontato carter	Preassembled casing	Preensamblado cárter	1
05	2.014.02.046	Premontato albero	Preassembled shaft	Preensamblado eje	1
06	4.016.02.006	Cuscinetto 6207	Bearing 6207	Cojinete 6207	2
07	1.074.02.007	Flangia posteriore	Back flange	Brida posterior	1
08	1.073.02.003	Ventola	Fan	Ventilador	1
09	1.045.02.005	Fascetta	Clamp	Faja	1
10	1.046.02.012	Protezione ventola	Fan protection	Protección ventilador	1
11	4.002.94.015	Vite autofilettante 3,9x9,5	3,9x9,5 self tapping screw	Tornillo autoblocante 3,9x9,5	4
12	4.002.11.002	Vite M8x25	M8x25 screw	Tornillo M8x25	12
13	4.049.12.003	Anello	Ring	Anillo	1
17	1.074.02.035	Flangia anteriore	Front flange	Brida anterior	1
15	3.055.02.001	Giunto	Coupling	Junta	1
16					
14	1.074.02.034	Flangia	Flange	Brida	1
18	4.006.02.011	Cuscinetto 6010	Beaing 6010	Cojinete 6010	1

COMPLESSIVO MOTOPOMPA – MOTORPUMP LAYOUT –
ESQUEMA GENERAL MOTOBOMBA

Pos.	Cod.	Descrizione	<i>Description</i>	Descripción	N°
19					
20	4.021.02.005	Chiavetta	Cotter	Chaveta	1
21					
22					
23	4.004.42.005	Grano	Grub screw	Grano	1
24	1.131.02.009	Mozzo Ø24	Ø24 hub	Cubo Ø24	1
25	1.157.02.001	Ammortizzatore giunto	Coupling cushion	Amortiguador junta	12
26	1.131.02.006	Mozzo Ø38	Ø38 hub	Cubo Ø38	1
27	3.002.12.033	Motore elettrico	Electric motor	Motor eléctrico	1