



# KRÜGER®

Ahora, más industrial.

**DESPIECE TÉCNICO**



30 años  
1978-2008



**Cleaning machines** s.l.

Pol. Agustinos C/ G, Parcela B2 31013 PAMPLONA (Navarra) SPAIN  
Tfno.: 948 318 405 - 948 317 616 Fax: 948 318 453

## **KHG170F - KHG200F**

visite: **[www.kruger.es](http://www.kruger.es)**

## CONTENTS

1. Crankcase Assy .....	2
2. Crankcase Cover Assy .....	4
3. Crankshaft Piston & Connecting rod Assy .....	5
4. Cylinder Head & Cylinder Cover Assy .....	6
5. Combination of Camshaft & Valve Rocker .....	8
6. Kick Starter .....	9
7. Carburetor Assy .....	10
8. Air Cleaner Assy .....	11
9. Regulating Control System .....	12
10. Muffler Assy .....	13
11. Fuel tank Assy .....	14
12. Flywheel Assy .....	15
13. Emblem .....	16
14. Principle diagram of Electricity .....	17

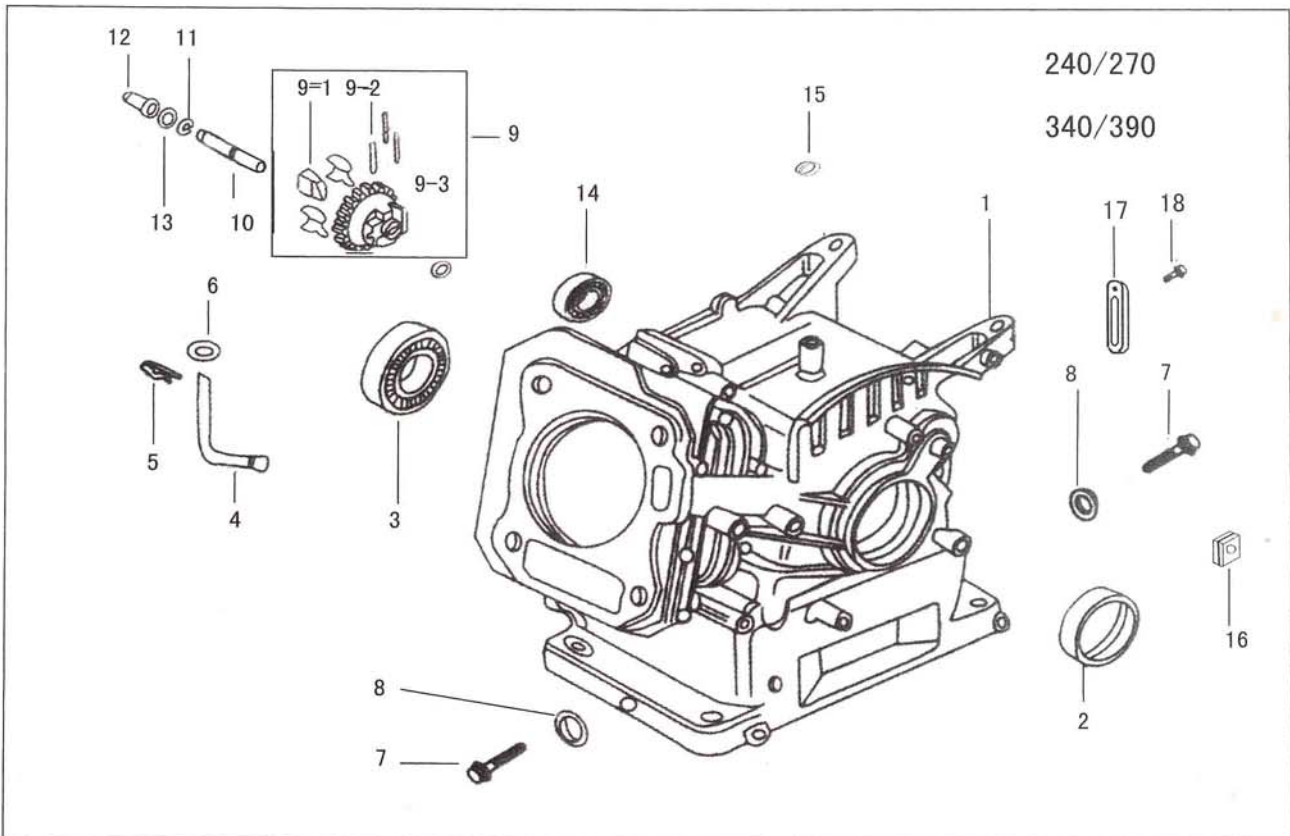
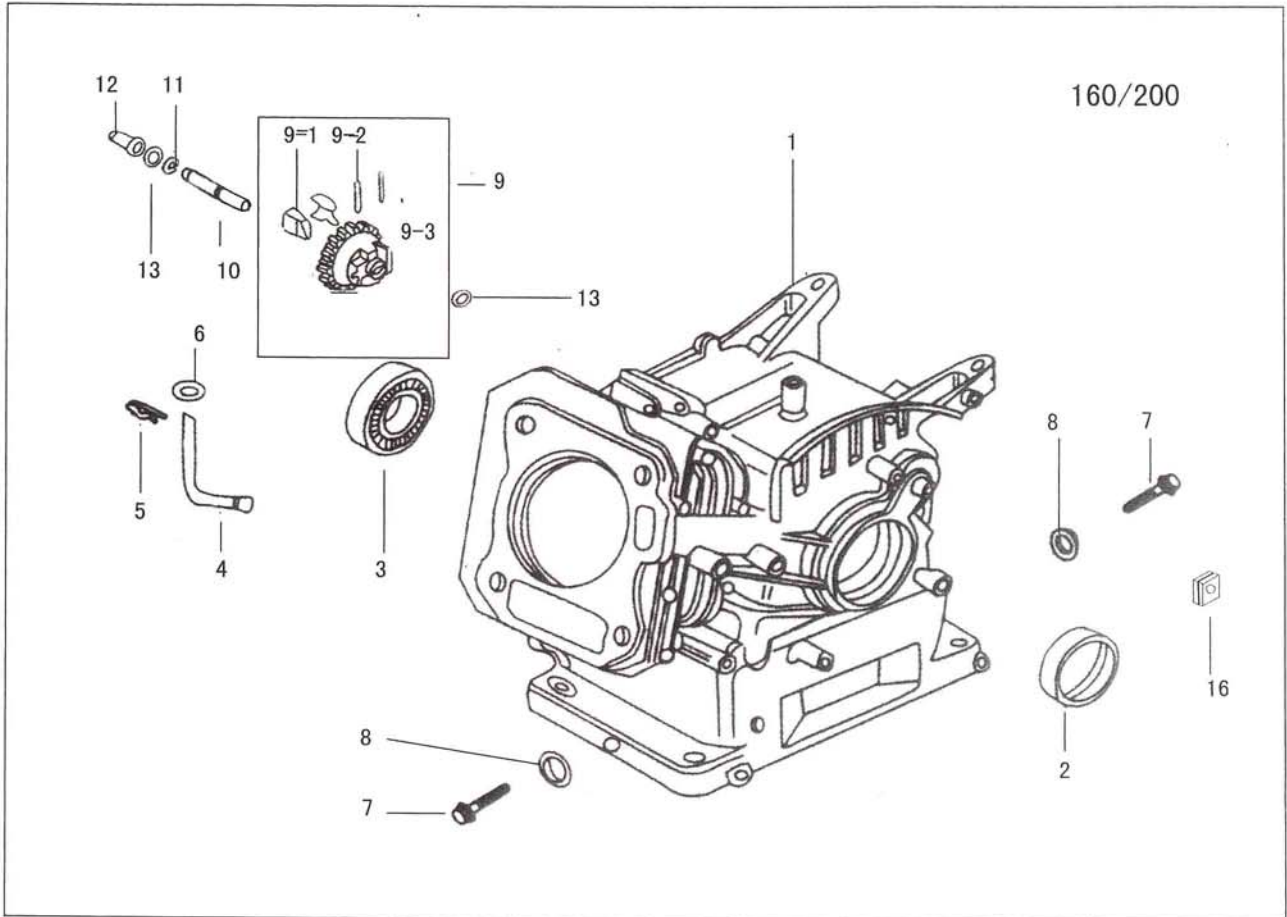

# 1. Crankcase Assy

	CODE			DESCRIPTION			QUANTITIES		
	160	240	340	160	240	340	160	240	340
	200	270	390	200	270	390	200	270	390
101	16001001	24001001	34001001	crankcase			1		
	20001001	27001001	39001001						
102	YF254125	YF304608	YF355208	oil seal			1		
				25×41.25×6	30×46×8	35×52×8			
103	ZC6205	ZC6206	ZC6207	radial ball bearing			1		
				6205	6206	6207			
104	16001002	24001002	34001002	governor arm shaft			1		
105	16001003	24001003		lock nip			1		
				8mm	10mm				
106	16001004	24001004		plain washer			1	2	
				φ 6	φ 8				
107	LSB10015	LSB12015		drain plug bolt			2		
108	16001005	24001005		drain plug washer			2		
109	16001100	24001100	34001100	overnor Kit			1		
1091	16001101	24001101	34001101	governor weight			2	3	
1092	16001102	24001102	34001102	governor weight, pin			2	3	
1093	16001103	24001103	34001103	governor gear			1		
110	16001006	24001006		governor sheft			1		
111	16001007			governor shaft clip			1		
112	16001008	24001008		governor			1		
113	16001004			plain washer φ6			3	1	
114	/		ZC6202	radial ball bearing			/		1
				6202					
115	/		YF081405	oil seal			/		1
				8×14×5					
116	16001010	24001010		String ring			1		
117	24001011			Dip clip			1	2	2
118	LSB06010			flange bolt M6×10			1	2	2

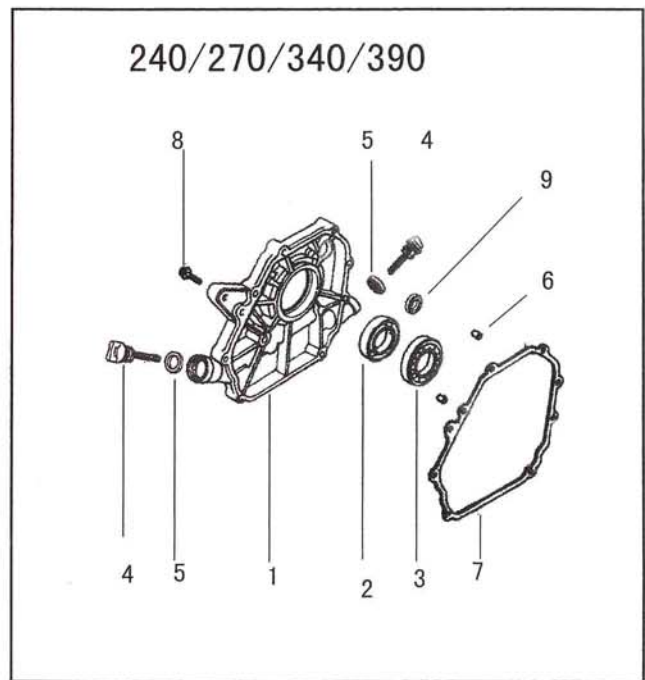
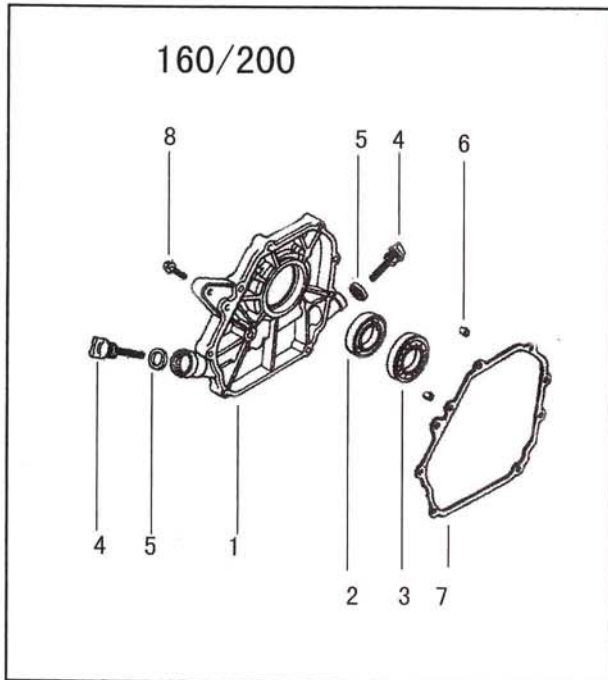

## 2. Crankcase Cover Assy

	CODE			DESCRIPTION			QUANTITIES		
	160	240	340	160	240	340	160	240	340
	200	270	390	200	270	390	200	270	390
201	16002001	24002001	34002001	Crankcase Cover			1		
202	YF254125	YF304608	YF355208	oil seal			1		
				25×41.25×6	30×46×8	35×52×8			
203	ZC6205	ZC6206	ZC6207	radial ball bearing			1		
				6205	6206	6207			
204	16002002	24002002		oil filler cap			2		
205	16002003			oil filler cap gasket			2		
206	XA0814			dowel pin $\phi 8 \times 14$			2		
207	16002004	24002004	34002004	case cover packing			1		
208	LSC080335	LSC08038		flange bolt			6 7		
				M8×33.5	M8×38				
209	/		ZC6202	radial ball bearing			/		
				/		6202	1		

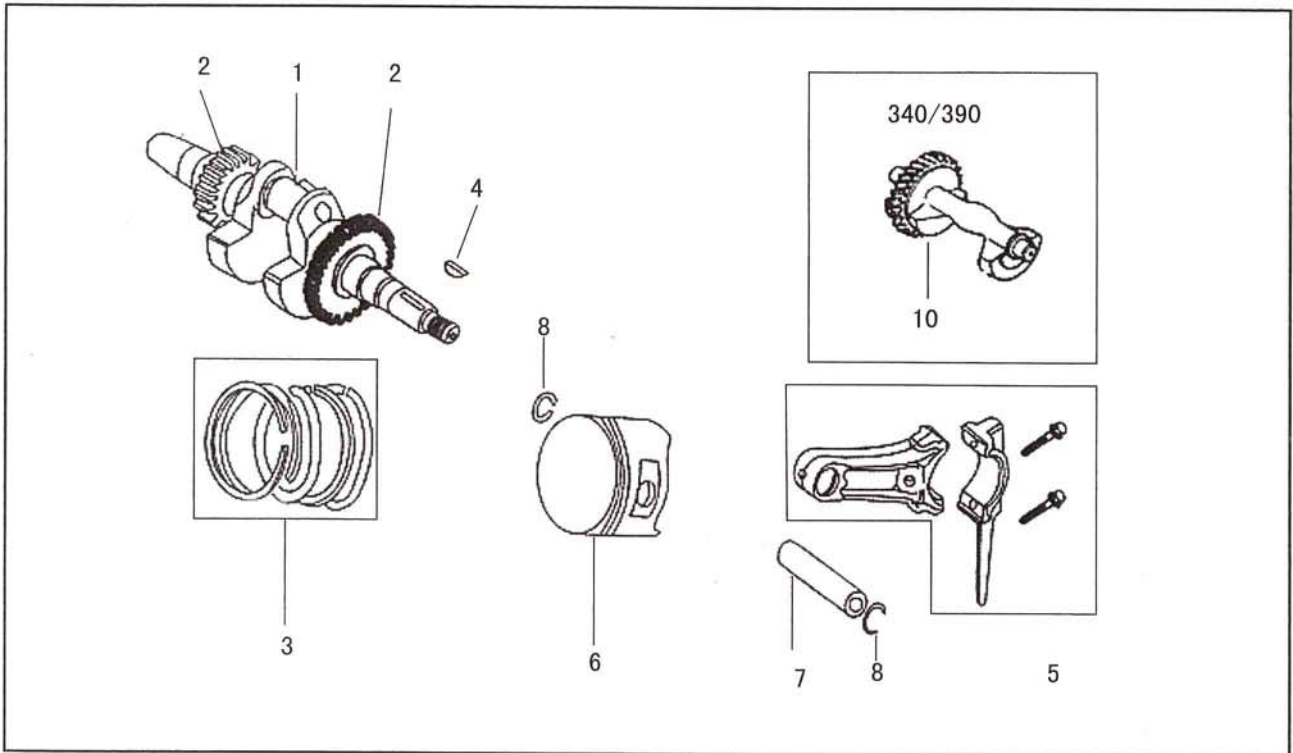

### 3. Crankshaft Piston & Connecting rod Assy

	CODE			DESCRIPTION			QUANTITIES		
	160	240	340	160	240	340	160	240	340
	200	270	390	200	270	390	200	270	390
301	16003101 20003001	24003101	34003101	crankshaft			1		
302	16003102	24003102	34003102	timing driving gear			1		
303	16003103	24003103	34003103	drive gear			1		
304	YJA0418			woodruffkey 4×18			1		
305	16003200	24003200	34003200	rod assy connecting			1		
306	16003004 20003004	24003004 27003004	34003004 39003004	piston			1		
307	16003005	24003005	34003005	piston pin			1		
308	16003006	24003006	34003006	piston pin clip			2		
309	16003300	24003300 27003300	34003300 39003300	piston ring set			1		
310			34003008	balance shaft					1

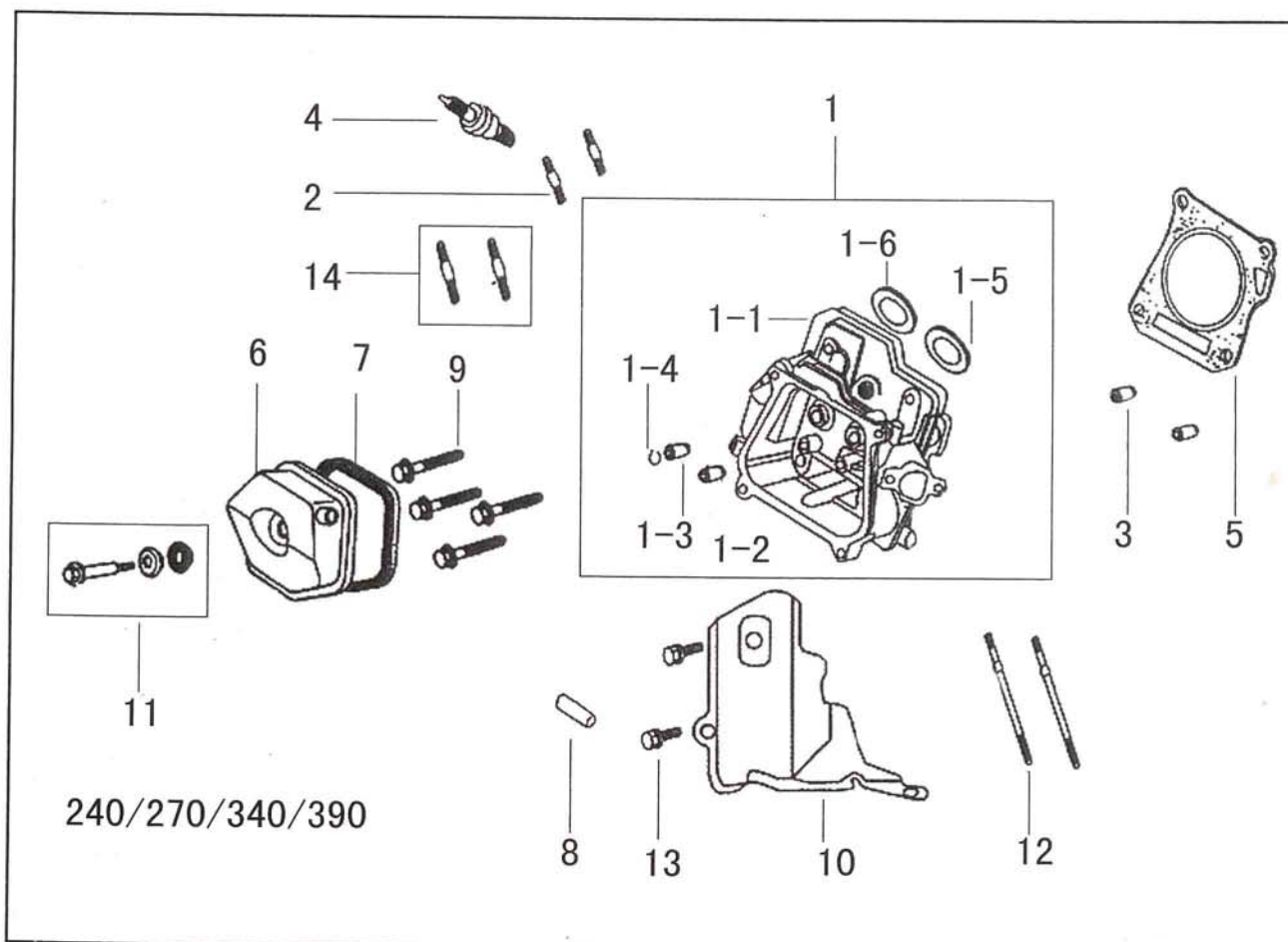
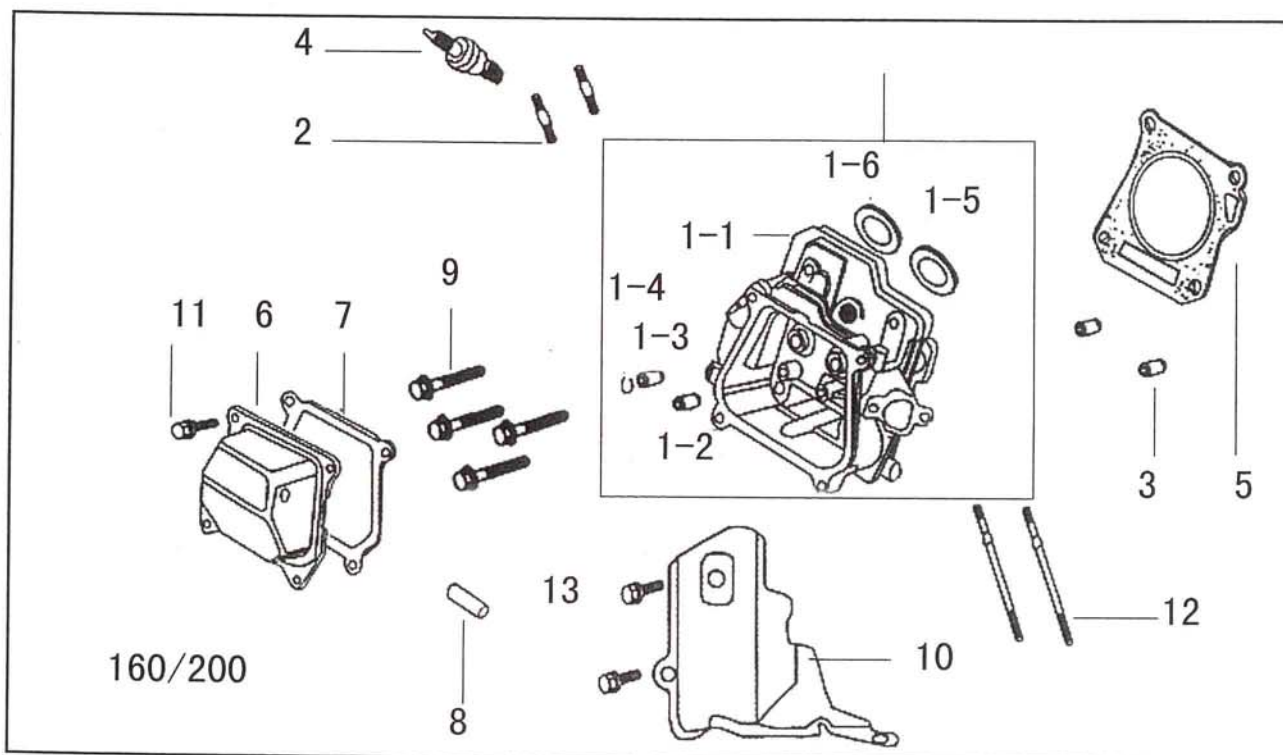

4. Cylinder Head & Cylinder Cover Assy									
	CODE			DESCRIPTION			QUANTITIES		
	160	240	340	160	240	340	160	240	340
	200	270	390	200	270	390	200	270	390
401	16004100 20004100	24004100	34004100	cylinder head comp			1		
4011	16004101 20004101	24004101	34004101	cylinder head			1		
4012	16004102	24004102	34004102	in-valve guide			1		
4013	16004103	24004103		ex-valve guide			1		
4014	16004104	24004104		valve guide clip			1		
4015	16004105	24004105	34004105	intake valve seat			1		
4016	16004106	24004106	34004106	exhaust valve seat			1		
402	LZA08020	LZA08032		stud bolt			2		
				AM8×20	AM8×32				
403	XA1016	XA1220		dowel pin			2		
				φ10×16	φ12×20				
404	16004200	24004200		spark plug			1		
				T4197J	F7TC				
405	16004001	24004001 27004001	34004001 39004001	cylinder head gasket			1		
406	16004300	24004300		head cover comp			1		
407	16004002	24004002		head cover packing			1		
408	16004003	24004003		breather tube assy			1		
409	16004004	24004004		head cover bolt			4		
				M8×60	M10×80				
410	16004005	24004005	34004005	lead wind cover			1		
411	LSB06012	24004006		screw M6×12	head cover boit ass		4	1	
412	16004007	24004007	34004007	stud bolt			2		
413	LSB06012			flange boitM6×12			2	1	
414	LZA08024			stud boltAM8×24			2		
415	16004008	24004008	34004008	stud bolt			2	2	2



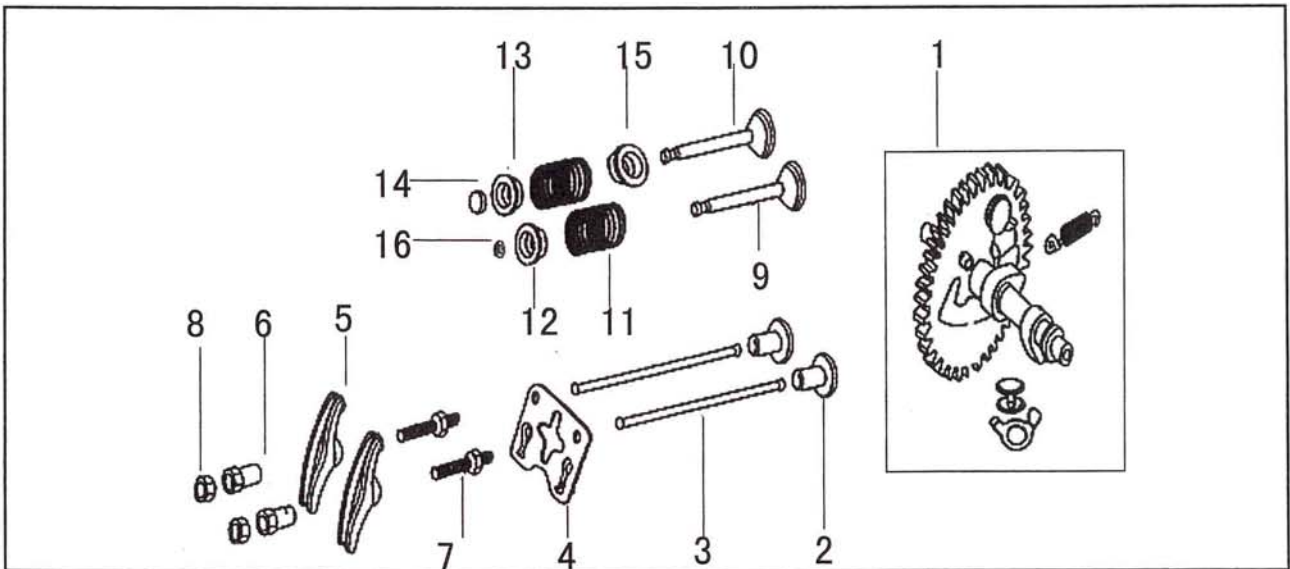

5. Combination of Camshaft & Valve Rocker									
	CODE			DESCRIPTION			QUANTITIES		
	160	240	340	160	240	340	160	240	340
	200	270	390	200	270	390	200	270	390
501	16005100 20005100	24005100	34005100 39005100	camshaft assy			1		
502	16005001 20005001	24005001		valve tappet			2		
503	16005002	24005002	34005002	push rod			2		
504	16005003	24005003		push rod guide plate			1		
505	16005201	24005201		valve rocker			2		
506	16005202			rocker pivot pin			2		
507	16005203			pivot bolt			2		
508	16005204			pivot adjusting nut			2		
509	16005004	24005004	34005004	in-take valve			1		
510	16005005	24005005	34005005	exhaust valve			1		
511	16005006	24005006		valve spring			2		
512	16005007	24005007		in-valve spring seat			1		
513	16005008	24005008		ex-valve spring seat			1		
514	16005009	24005009		valve rotatr			1		
515		24005010		spring retainer exhaust valve					1
516			34005011	guide oil seal					1

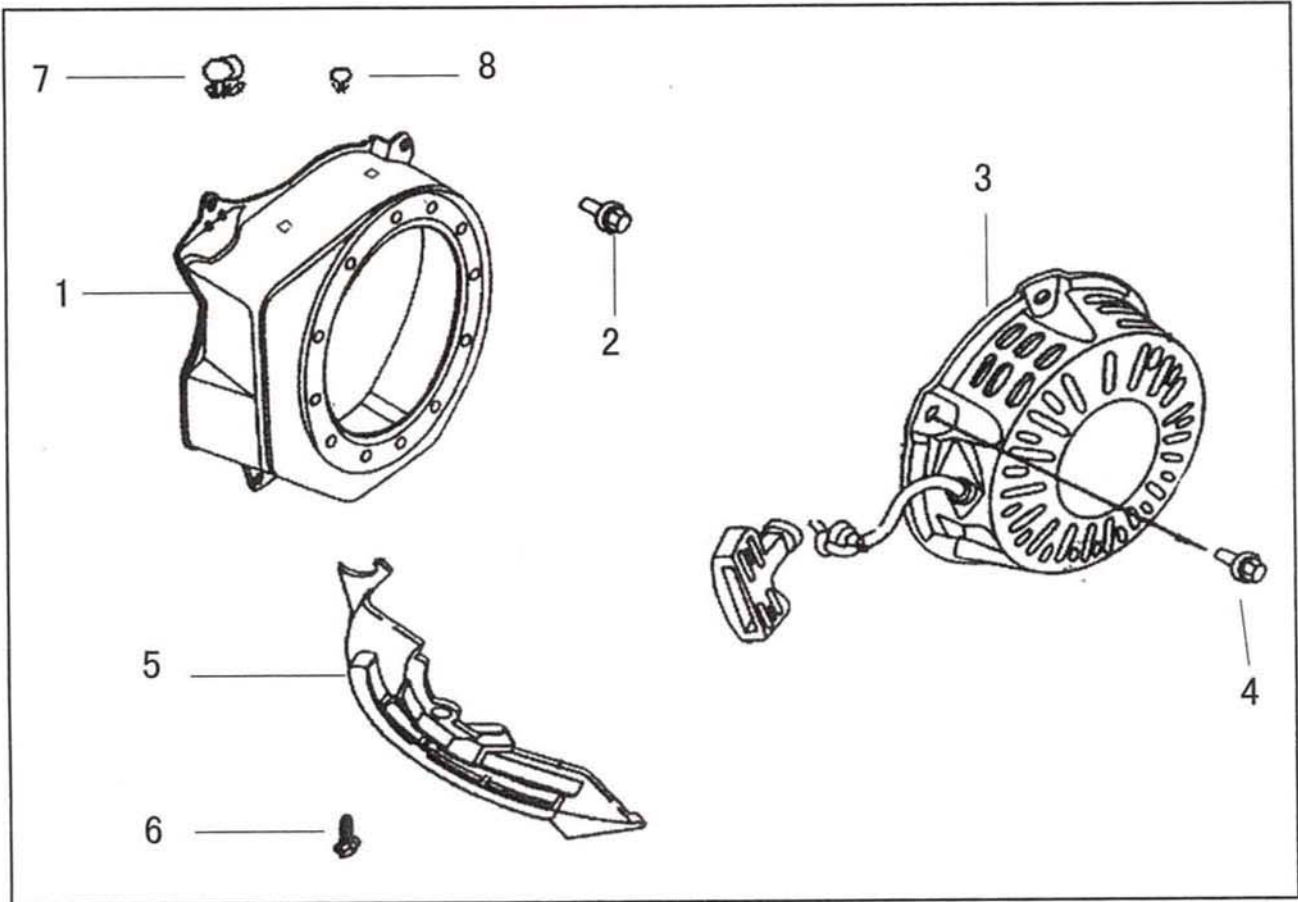

6. Kick Starter									
	CODE			DESCRIPTION			QUANTITIES		
	160	240	340	160	240	340	160	240	340
	200	270	390	200	270	390	200	270	390
601	16006100	24006100	34006100	fan hood			1		
602	LSB06012			flange boit M6×12			4	5	
603	16006200	24006200	34006200	starter rolls assy			1		
604	LSB06008	LSB06010		flange boit		3			
				M6×8	M6×10				
605	16006001	/			shroud comp		1	/	
606	LSB06012	/			screw M6×12		2	/	
607	/		24006001	Swallow clip			/		2
608	/		24006002	Twin clip			/		1
601-1	1066100E	/			fan hood		1	/	
605-1	1606001E	/			shroud comp		1	/	

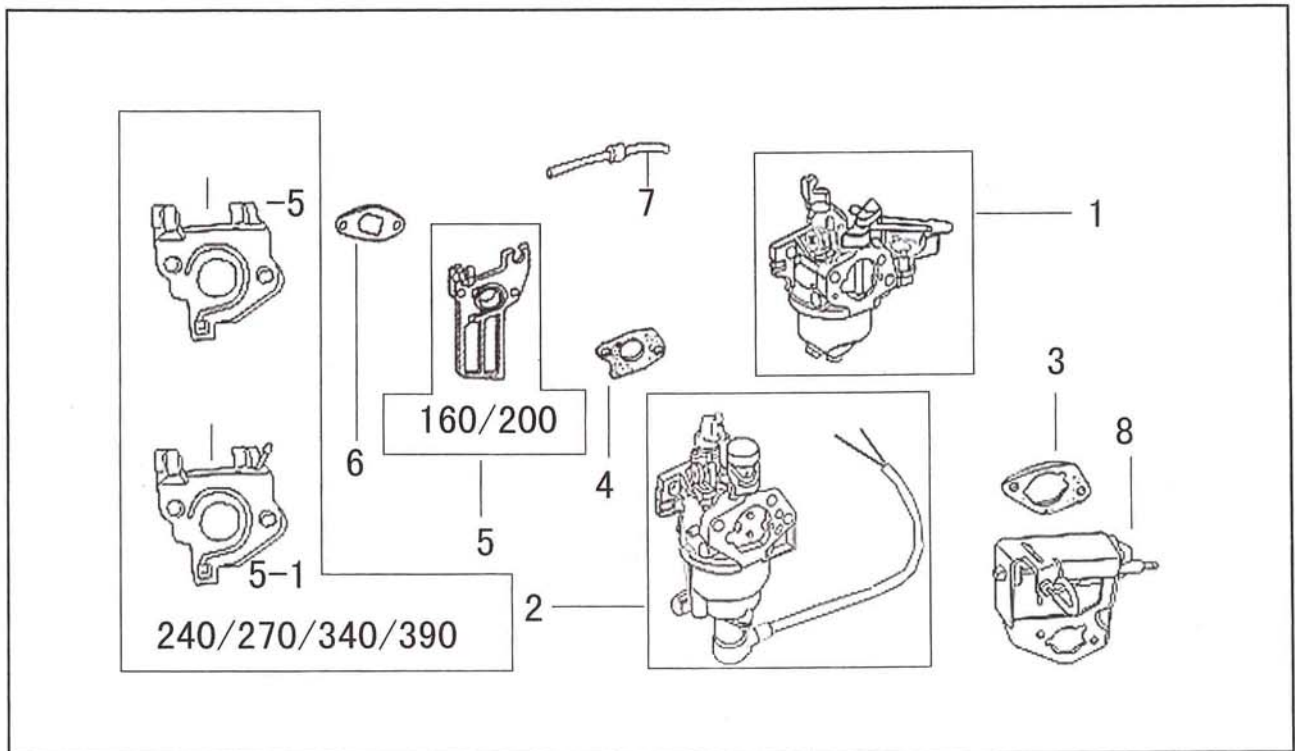

7. Carburetor Assy									
	CODE			DESCRIPTION			QUANTITIES		
	160	240	340	160	240	340	160	240	340
	200	270	390	200	270	390	200	270	390
701	16007100	24007100	34007100	carburetor Assy			1		
	20007100	27007100	39007100						
702	16007200	24007200	34007200	carburetor Assy					
	20007200	27007200	39007200						
703	16007001	24007001	34007001	air cheaner gesket			1		
			39007001						
704	16007002	24007002	34007002	carburetor gasket			1		
			39007002						
7041	16007003	24007003	34007003	connecting block			1		
			39007003						
705		24007300	34007300	connecting block					
			39007300						
706	16007004	24007004	34007004	inlet gasket			1		
707		24007400		check valve assy					1
708		24007500		manual chke assy					1

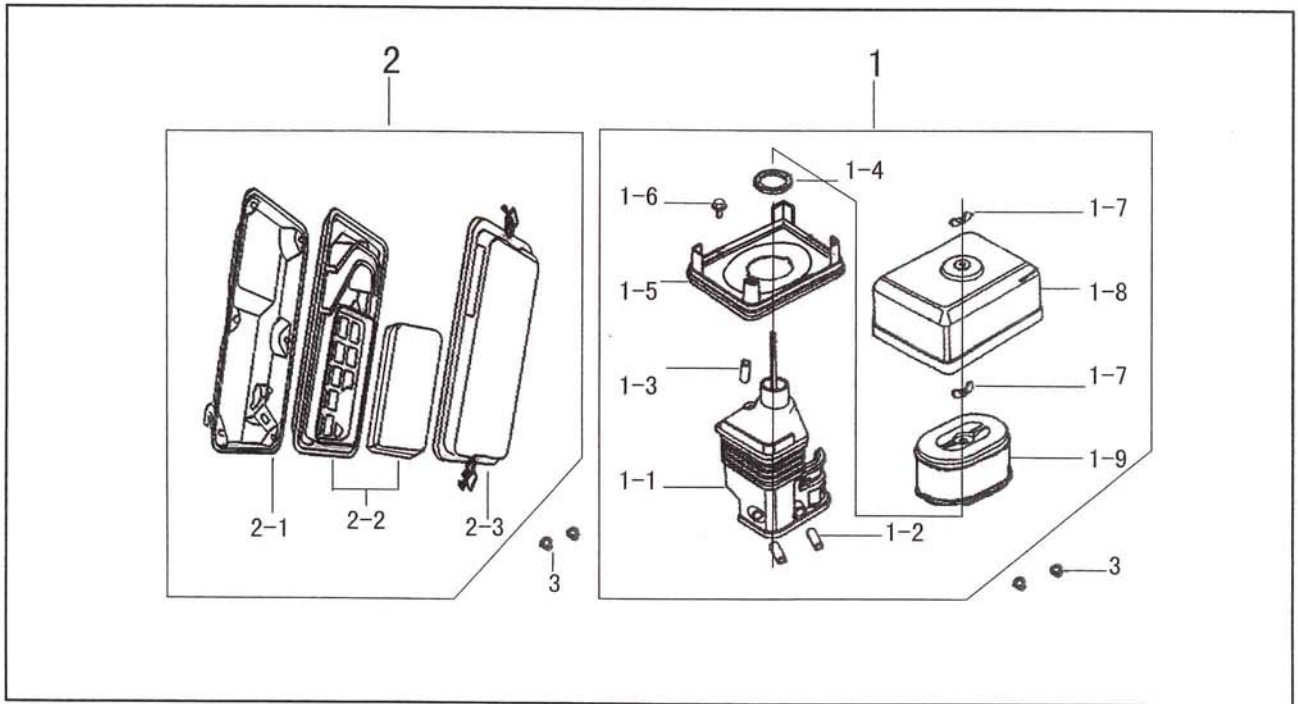

8. Air Cleaner Assy									
	CODE			DESCRIPTION			QUANTITIES		
	160	240	340	160	240	340	160	240	340
	200	270	390	200	270	390	200	270	390
801	16008100	24008100	34008100	Air cleaner Assy					
802	16008200	24008200	34008200	Air cleaner Assy					
8011	16008101	24008101		Air cleaner elbow comp			1		
8012	16008102	24008102		Air cleaner collar A			2		
8013	16008103	24008103		Air cleaner collar B			1		
8014	16008104	24008104		Elbow packing			1		
8015	16008105	24008105	34008105	Air cleaner base			1		
8016	LSB04010			Bolt M4×14			2		
8017	LMD06			Cover nut M6			2		
8018	16008106	24008106		Air cleaner cover			1		
8019	16008107	24008107		Air cleaner element			1		
8021	16008201	24008201		Air cleaner elbow comp			1		
8022	16008202	24008202		Air cleaner element			1		
8023	16008204	24008204		Air cleaner cover			1		
803	LMB06			Nut M6			2		

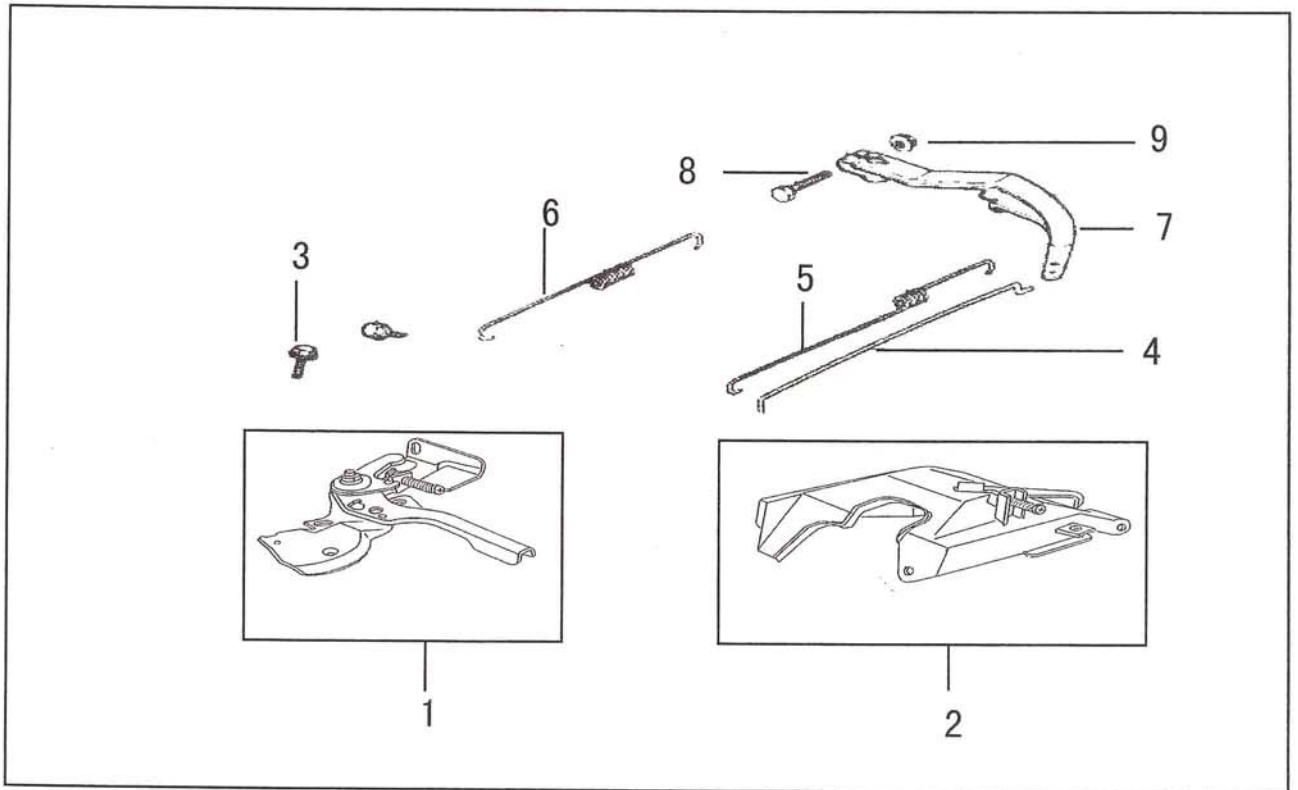

9. Regulating Control System									
	CODE			DESCRIPTION			QUANTITIES		
	160	240	340	160	240	340	160	240	340
	200	270	390	200	270	390	200	270	390
901	16009100	24009100	34009100	speed control assy					
902	16009200	24009200	34009200	speed control assy					
903	LSB06012			flange boit M6×12			2		
904	16009001	24009001	34009001	governor rod			1		
905	16009002	24009002	34009002	throttle return spring			1		
906	16009003	24009003	34009003	governor spring			1		
907	16009004	24009004	34009004	regulating arm			1		
908	16009005			governor arm boltM6×21			1		
909	LMBO			bolt M6			1		

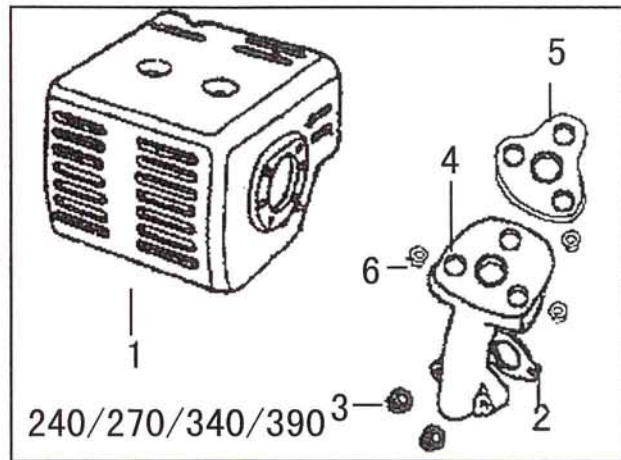
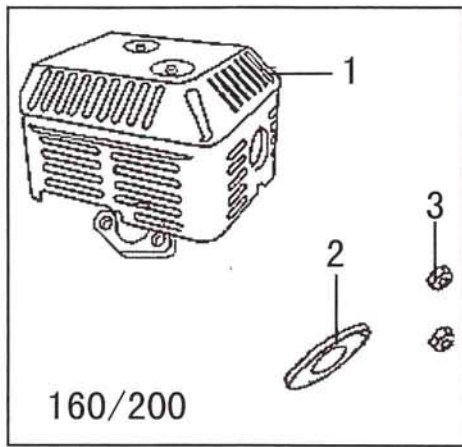

10. Muffler Assy									
	CODE			DESCRIPTION			QUANTITIES		
	160	240	340	160	240	340	160	240	340
	200	270	390	200	270	390	200	270	390
1001	16010100	24010100	34010100	muffler Assy			1		
1002	16010001	24010001		muffler gasket			1		
1003	LMB08			bolt M8			2		
1004	/	24010002		exhaust valve tube			/	1	
1005	/	24010003		mufflet gasket			/	1	
1006	/	LMB08		bolt M8			/	3	

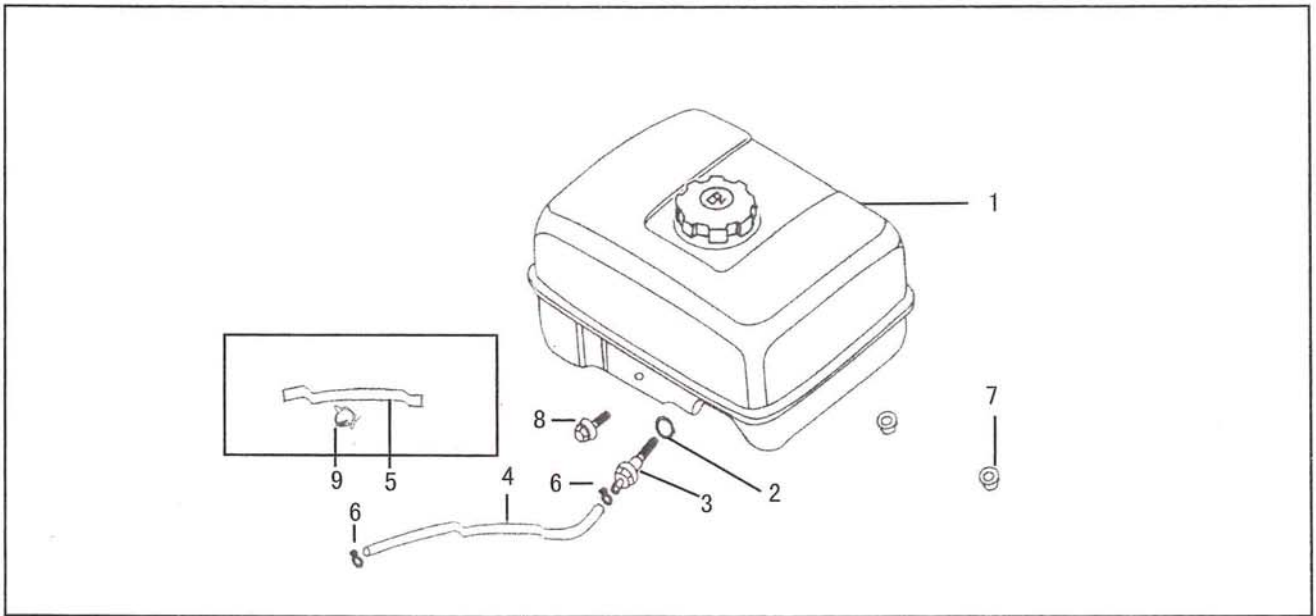

11. Fuel tank Assy									
	CODE			DESCRIPTION			QUANTITIES		
	160	240	340	160	240	340	160	240	340
	200	270	390	200	270	390	200	270	390
1101	16011100	24011100	34011100	fuel tank Assy			1		
1102	16011002			gasket			1		
1103	16011003	24011003		fuel tank joint			1		
1104	16011004	24011004	34011004	fuel tube			1		
				4.5×140	4.5×150	4.5×160			
1105		24011005		supporter rubber pipe				1	
1106	16011006			tube clip			2		
1107	LMB06	LMB08		bolt			2		
				M6	M8				
1108	LSB06022	LSB08022		screw			1	2	
				M6×22	M8×22				
1109		24011007	34011007	oil tube clarnp				1	

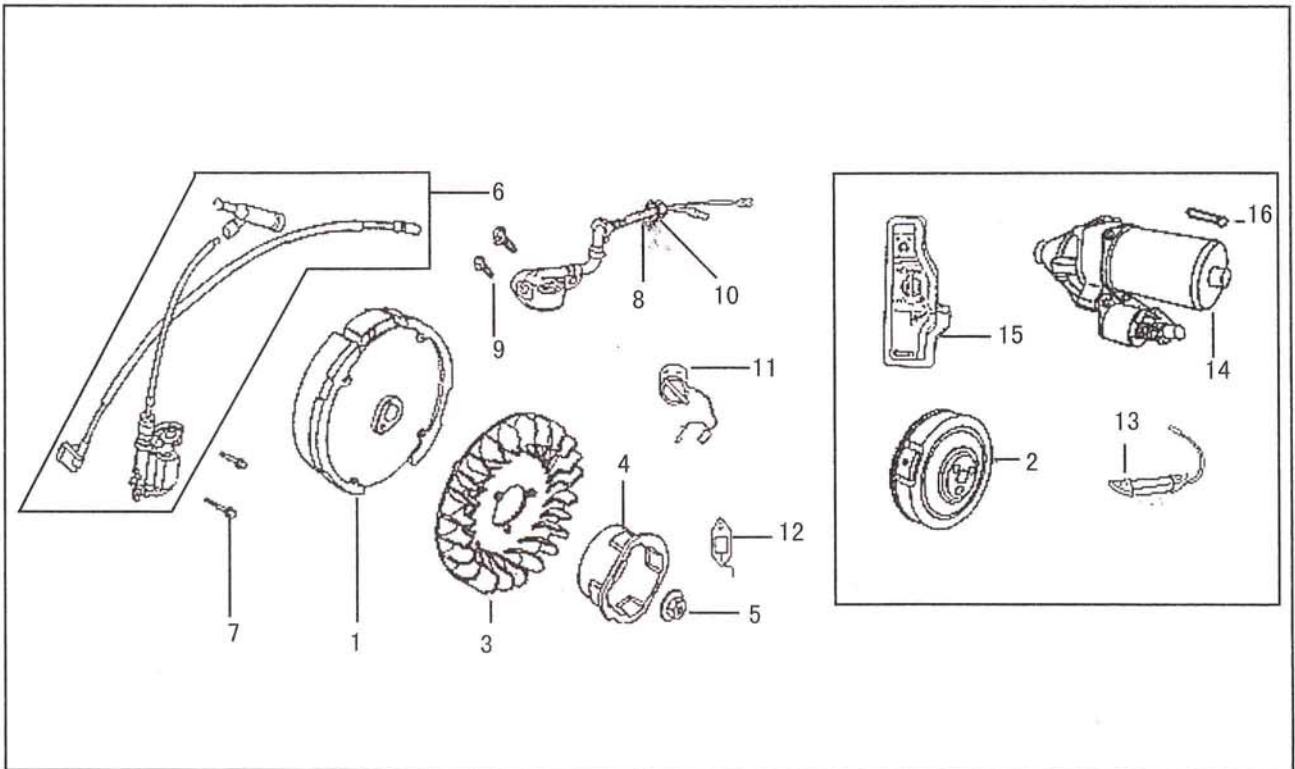

12. Flywheel Assy									
	CODE			DESCRIPTION			QUANTITIES		
	160	240	340	160	240	340	160	240	340
	200	270	390	200	270	390	200	270	390
1201	16012100	24012100	34012100	flywheel comp			1		
1202	16012100E	24012100E	34012100E	flywheel comp					
1203	16012001	24012001	34012001	cooling fan			1		
1204	16012002	24012002	34012002	starter pulley			1		
1205	16012003	24012003		flywheel special nut			1		
				M14×1.5	M16×1.5				
1206	16012004	34012004		ignition coil			1		
1207	LSB06028			flange boit M6×28			2		
1208	16012005	24012005		oil sensor			1		
1209	LSB06014			flange boit M6×14			2		
1210	LMB10			special nut M10			1		
1211	16012006			engine stop switch assy			1		
1212	16012007			diode			1		
1213	24012008			Charging coil			1		
1214	16012400	24012400	34012400	Starting motor assem			1		
1215	16012500	24012500		Control clawp assem			1		
1216	XA0810			Starting motor dowel pin			2		





13.		Emblem								
	CODE			DESCRIPTION			QUANTITIES			
	160	240	340	160	240	340	160	240	340	
	200	270	390	200	270	390	200	270	LT390	
1301	16013001	24013001	34013001	Model label			1			
	20013001	27013001	39013001							
1302	16013002			Emblem.choke lever			1			
1303	16013003			Emblem, adding			1			
1304	16013005			Emblem, maintenance of air cleaner			1			
1305	16013006			Emblem, Note: add oil before using			1			
1306	16013008			Emblem, tortoise and rabbit			1			
1307	16013009			Emblem, maintenance of air cleaner			1			

14.

Principle Diagram of Electricity

