

KHF15015I

Serial number:

Code:



Electrical connection: **400 V - 50 Hz - 3 ~**

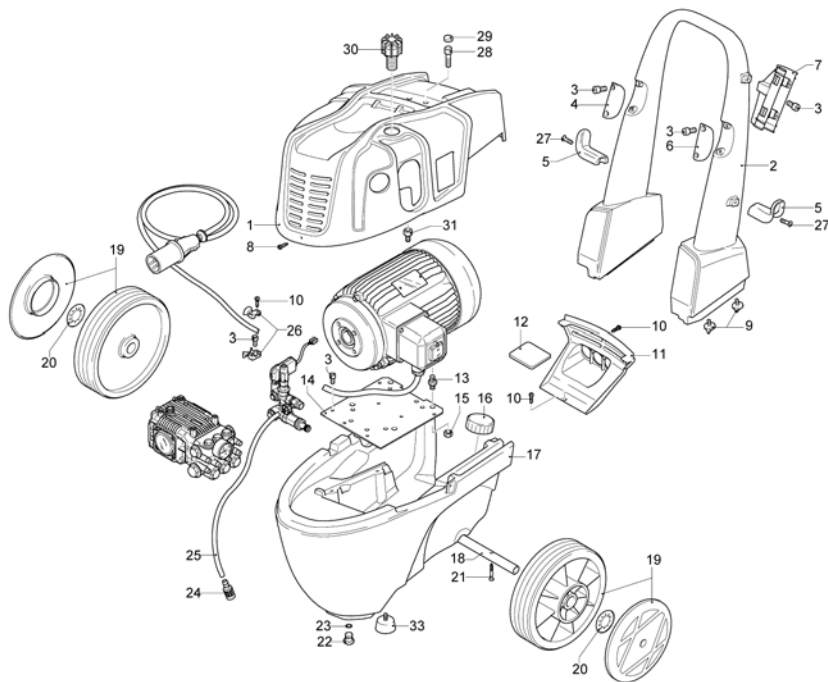

Pos.	Code	Description	Q.ty
1	2360637	Blue casing	1
2	2360020	Handle	1
3	2360360	Screw	9
4	2360300	Plug	1
5	2360090	Hook	2
6	2360170	Plug	1
7	2360100	Support	1
8	2100300	Screw	3
9	2360270	Knob	4
10	2000110	Screw	4
11	2360040	Black casing	1
12	2360370	Gasket	1
13	2360340	Stud bolt	4
14	2360050	Plate	1
15	380240	Ring	4
16	1680930	Plug	1
17	2360010	Base	1
18	2360560	Axle	1
19	2360571	Wheel	2
20	380620	Washer	2
21	1470220	Screw	2
22	1682420	Plug	1
23	2000240	O-ring	1
24	2000230	Filter	1
25	1270960	Detergent hose	1
26	2360110	Clamp	1
27	2100300	Screw	2
28	850250	Screw	2
29	1270910	Plug	2
30	2360760	Knob	1
31	2360670	Stud bolt	2
33	2360780	Vibration damper	2

KHF15015I

Serial number:

Code:



Electrical connection:

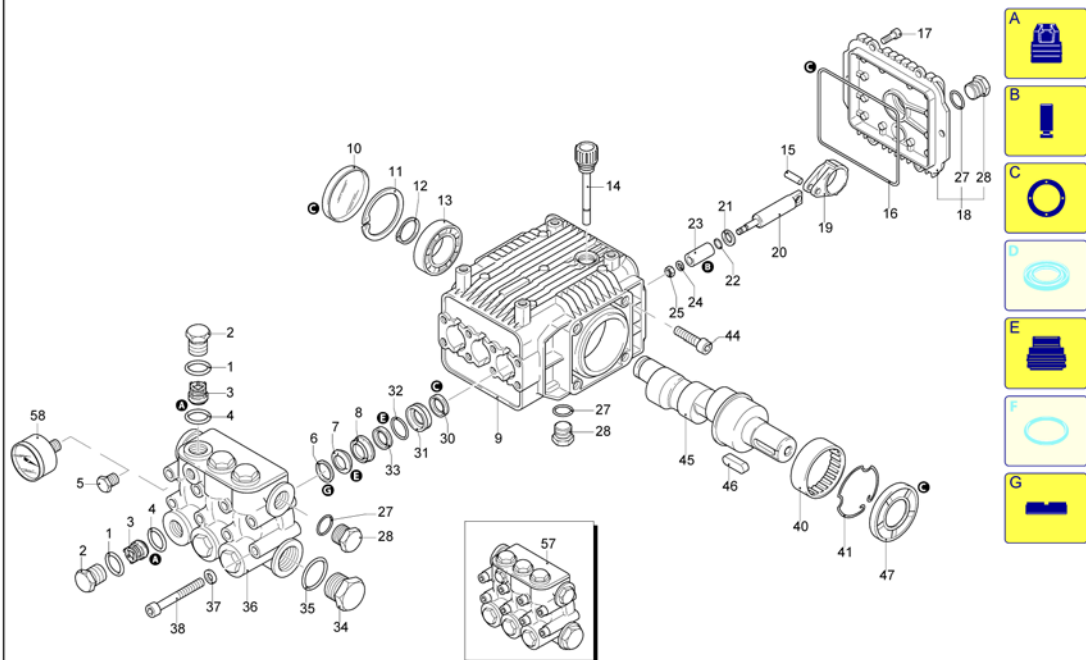

Pos.	Code	Description	Q.ty
1	960160	O-ring	6
2	1260162	Plug	6
3	1269050	Valve	6
4	880830	O-ring	6
5	620301	Plug	1
6	1780140	Ring	3
7	1260220	Water seal	3
8	1780110	Piston guide	3
9	1780010	Pump body	1
10	1266740	Oil seal	1
11	1260790	Ring	1
12	1780550	Ring	1
13	1780490	Bearing	1
14	1682420	Plug	1
15	1780050	Pin	3
16	1780510	O-ring	1
17	1200430	Screw	6
18	1789010	Cover	1
19	1780040	Connecting-rod	3
20	1780060	Pin	3
21	480480	O-ring	3
22	1260091	Plate	3
23	1780080	Piston	3
24	1260100	Washer	3
25	1260110	Nut	3
27	740290	O-ring	3
28	1980740	Plug	3
30	1260460	Oil seal	3
31	1780120	Piston guide	3
32	770260	O-ring	3
33	1260450	Water seal	3
34	820361	Plug	1
35	180101	O-ring	1
36	1780020	Head	1
37	1381550	Washer	8
38	1322730	Screw	8
40	1321190	Bearing	1
41	1321080	Ring	1
44	180030	Screw	4
45	1780180	Shaft	1
46	1380520	Key	1
47	1260750	Oil seal	1
57	1789202	Head assembly	1
58	3232	Pressure gauge	1
A	1864	Valve kit	1
B	2746	Piston kit	1
C	2786	Oil seal kit	1
E	2747	Water seal kit	1
G	2745	Support ring kit	1

KHF15015I

Serial number:

Code:



Electrical connection:

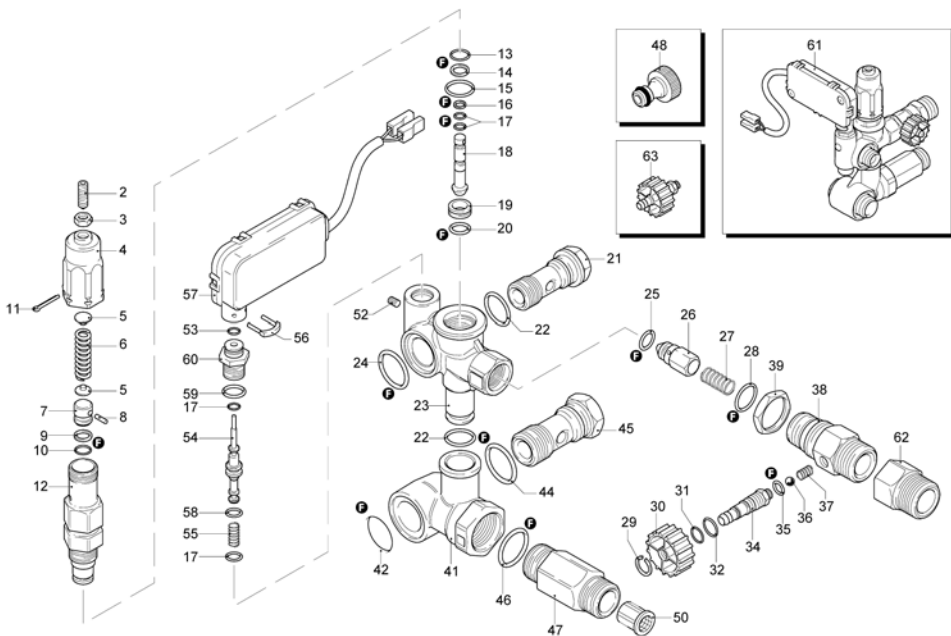

Pos.	Code	Description	Q.ty
2	392840	Screw	1
3	1980300	Nut	1
4	2500540	Insert	1
5	1980220	Wobble plate	2
6	1271070	Spring	1
7	1080041	Piston	1
8	1080070	Pin	1
9	1080401	Ring	1
10	1080250	O-ring	1
11	2500550	Split pin	1
12	1980210	Piston guide	1
13	740290	O-ring	1
14	800560	O-ring	1
15	880830	O-ring	1
16	1271170	Ring	1
17	1080190	O-ring	4
18	1271160	Piston	1
19	2460420	Seat	1
20	1080250	O-ring	1
21	1540270	Screw	1
22	390080	O-ring	2
23	1540660	Valve body	1
24	1140450	O-ring	1
25	1460430	O-ring	1
26	1540170	Shutter	1
27	1080091	Spring	1
28	394280	O-ring	1
29	1560660	Ring	1
30	2360650	Knob	1
31	480560	O-ring	1
32	800560	O-ring	1
34	1560650	Hose tail	1
35	480480	O-ring	1
36	1250280	Ball	1
37	1560520	Spring	1
38	1540580	Fitting	1
39	1540300	Nut	1
41	1540280	Suction fitting	1
42	1540630	O-ring	1
44	880270	O-ring	1
45	2260420	Screw	1
46	480440	O-ring	1
47	1560900	Fitting	1
48	40393	Fitting	1
50	1340280	Filter	1
52	1981190	Screw	1
53	1260820	O-ring	1
54	1540881	Pin	1
55	1981320	Spring	1
56	2022200	Fork	1
57	2029758	TSS box assembly	1
58	660190	O-ring	1
59	880840	O-ring	1
60	1540870	Fitting	1
61	22078	Valve	1
62	1123960	Fitting	1
63	1569210	IDR assembly	1
F	2812	Gasket kit	1

KHF15015I

Serial number:

Code:



Electrical connection:

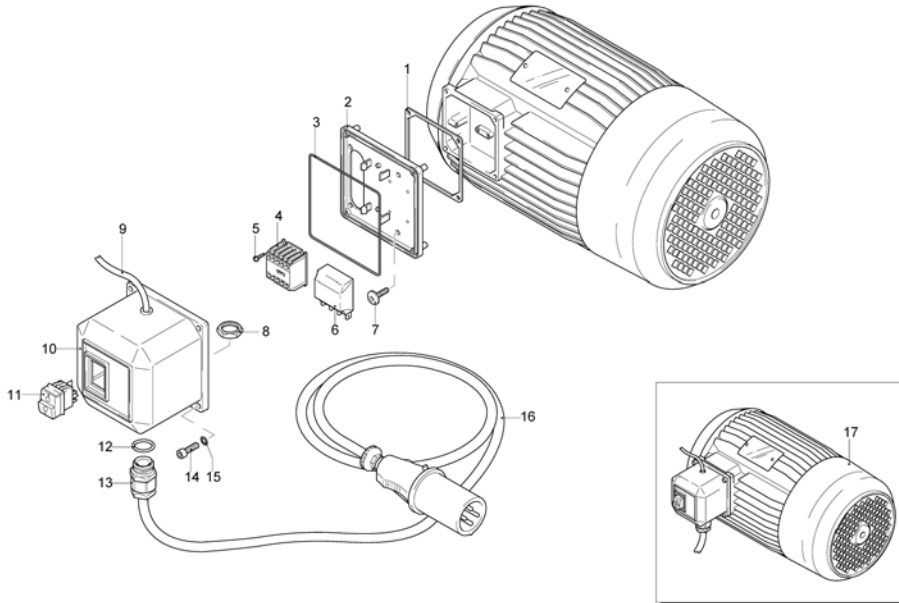

Pos.	Code	Description	Q.ty
1	1700110	O-ring	1
2	1700080	Plate	1
3	1940410	O-ring	1
4	1700740	Mini-contactor	1
5	1261570	Screw	4
6	2360590	Box	1
7	1460460	Screw	4
8	1700590	Nut	1
9	2180650	Cable	1
10	1700930	Cover	1
11	2360730	Switch	1
12	880270	O-ring	1
13	1382380	Cable gland	1
14	1261560	Screw	4
15	1080190	O-ring	4
16	1700640	Cable	1
17	44121	Motor	1

KHF15015I

Serial number:

Code:



Electrical connection:

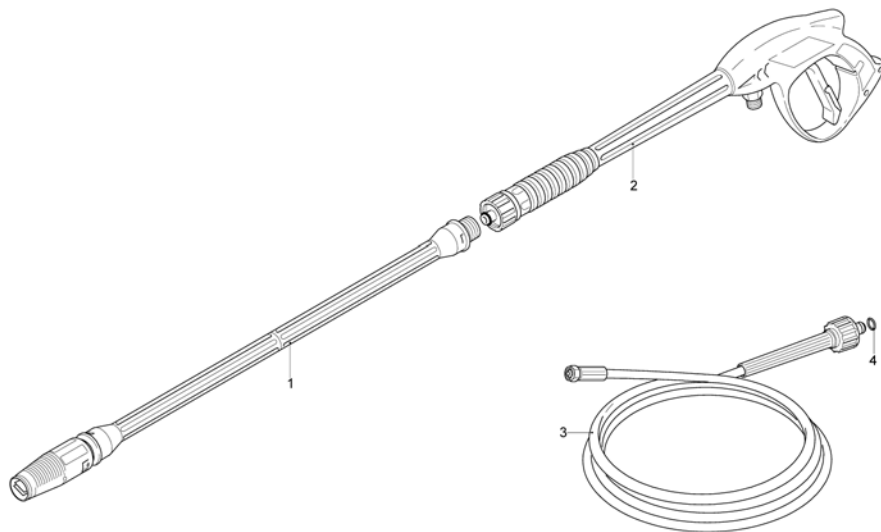

Pos.	Code	Description	Q.ty
1	40039	Lance+lance head	1
2	40171	Gun	1
3	1271960	High pressure hose	1
4	2000770	O-ring	1