

KGE1000

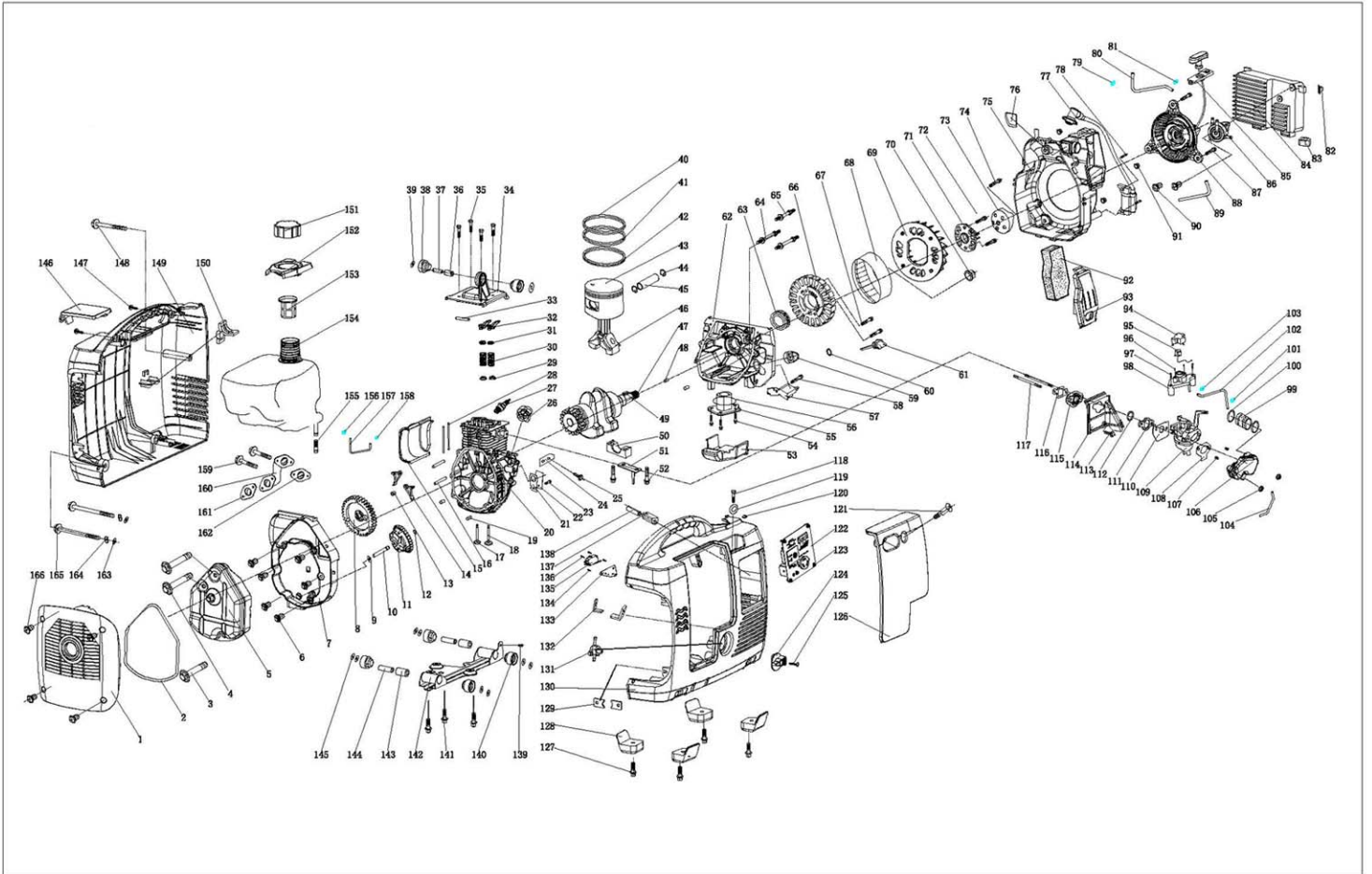

CATALOG

NO	Description	Qty	NO	Description	Qty	NO	Description	Qty	NO	Description	Qty
1	Muffler cover	1	45	Piston pin	1	89	Fuel pipe	1	133	Travel switch retaining plate	1
2	Muffler cover sealing ring	1	46	Connecting rod	1	90	Slotted round head screw M5*12	2	134	Slotted round head screw ST3.2*8	2
3	Hexagon flange bolt M6*40	1	47	Crankshaft	1	91	Hexagon flange nut M5	3	135	Position switch	1
4	Hexagon flange bolt M6*45	2	48	Dowel pin	1	92	Air filter core	1	136	Special slotted round head screw M3*15	2
5	Muffler	1	49	Woodruff key	1	93	Air filter cover	1	137	Fuel tank side vibration absorber pad	1
6	Hexagon flange bolt M5*20	6	50	Connecting rod cover	1	94	Stepper motor protecting cover	1	138	Sleeving 12.5*1*68	2
7	Gear cover	1	51	Stirring oil board	1	95	Stepper motor	1	139	Slotted round head screw M5*10	1
8	Camshaft	1	52	Connection rod bolt	1	96	Slotted round head screw M3*5	2	140	Bracket vibration absorber pad	4
9	Plain washer $\varnothing 4 \times 9 \times 0.8$	2	53	Crankcase base seal cover	1	97	Slotted round head screw M4*8	2	141	Hexagon flange bolt M6*12	3
10	Stirring oil gear shaft	1	54	Hexagon flange bolt M5*16	4	98	Stepper motor bracket	1	142	Vibration damper bracket	1
11	Stirring oil gear	1	55	Oil sensor	1	99	Air filter pipe	1	143	Sleeving 12.5*1*63	2
12	Clip	1	56	Oil sensor O-ring	1	100	Air filter pipe clip	2	144	Sleeving 10*1.5*87	2
13	Shifting bush	1	57	Trigger	1	101	Fuel pipe clip ($\varnothing 8$)	1	145	Plain washer $\varnothing 10 \times 25 \times 2$	8
14	Shifting yoke	2	58	Hexagon flange bolt M5*12	1	102	Fuel pipe	1	146	Spark plug maintenance cover	1
15	Muffler housing	1	59	Oil filler	1	103	Fuel pipe clip ($\varnothing 7$)	1	147	Slotted round head screw M6*20	2
16	Shifting pin	2	60	O-ring	1	104	Air filter pipe	1	148	Hexagon flange bolt M6*17.5	1
17	Exhaust valve	1	61	Oil dipstick	1	105	Hexagon flange nut M5	2	149	Back cover	1
18	Intake valve	1	62	Crankcase cover	1	106	Air filter connector	1	150	Fuel tank bottom vibration absorber pad	1
19	Gear cover pin	2	63	Oil seal 17*27*5	1	107	Bushing	2	151	Fuel tank cap	1
20	Crankcase	1	64	Special stud bolt M5*86	2	108	Carburetor gasket	1	152	Fuel tank cap vibration absorber pad	1
21	Breather valve	1	65	Special stud bolt M5*55	1	109	Carburetor	1	153	Fuel inlet strainer	1
22	Inhibiting plate of breather valve	1	66	Stator unit	1	110	Insulator seal	1	154	Fuel tank	1
23	Slotted round head screw M3*5	1	67	Hexagon flange bolt M5*25	2	111	Insulator (small)	1	155	Fuel discharge strainer	1
24	Retaining plate	1	68	Rotor unit	1	112	Insulator O-ring	1	156	Fuel pipe clip ($\varnothing 10$)	1
25	Hexagon flange bolt M5*12	1	69	Fan	1	113	Hexagon flange bolt M6*12	1	157	Fuel pipe	1
26	Wire net	1	70	Hexagon flange nut M10	1	114	Carburetor housing	1	158	Fuel pipe clip ($\varnothing 7$)	1
27	Spark plug	1	71	Starting coupling	1	115	Insulator (big)	1	159	Hexagon flange bolt M5*20	2
28	Push-rod	2	72	Hexagon flange bolt M6*16	2	116	Intake port seal	1	160	Muffler angel branch	1
29	Valve oil seal	2	73	Driving coupling	1	117	Stud bolt AM5*91	2	161	Muffler gasket (big)	1
30	Valve spring	2	74	Hexagon flange bolt M6*12	1	118	Slotted round head screw M5*10	1	162	Muffler gasket (small)	1
31	Valve-spring retainer	2	75	Fan cover	1	119	Plain washer $\varnothing 5 \times 10.5 \times 1$	1	163	Plain washer $\varnothing 6 \times 13.5 \times 2$	3
32	Valve rocker arm	2	76	Fan cover cap	1	120	Split washer	1	164	Spring washer M6	3
33	Rocker arm pin	1	77	T.C.I	1	121	Special bolt M6*18	1	165	Hexagon flange bolt M6*105	2
34	Cylinder head cover	1	78	Slotted round head screw ST4.8*24	2	122	Control panel unit	1	166	Hexagon flange bolt M5*20	4
35	Hexagon flange bolt M5*20	4	79	Fuel pipe clip $\varnothing 8$	1	123	Slotted round head screw M5*10	4			
36	Sleeving 12.5*1*21	1	80	Fuel pipe	1	124	Oil switch knob	1			
37	Sleeving 10*1.5*41	1	81	Fuel pipe clip $\varnothing 7$	1	125	Slotted round head screw M5*16	1			
38	Cylinder head cover vibration absorber pad	1	82	Side vibration absorber pad	1	126	Maintenance cover	1			
39	Plain washer $\varnothing 10 \times 25 \times 2$	2	83	Inverter vibration absorber pad	2	127	Hexagon flange bolt M6*12	4			
40	Piston ring I	1	84	Inverter	1	128	Generator vibration absorber pad	4			
41	Piston ring II	1	85	Recoil starter bracket	1	129	Special nut	2			
42	Oil ring unit	1	86	Fuel vacuum pump	1	130	Front housing	1			
43	Piston	1	87	Hexagon flange bolt M5*12	3	131	Fuel switch	1			
44	Piston stopper	2	88	Recoil starter unit	1	132	Muffler cover retaining plate	2			