



DESPIECE TÉCNICO
HIDROLIMPIADORA
KH200CI



Idropulitrice KH200CI 15-200 50Hz

Hochdruck Reiniger KH200CI 15-200 50Hz

High Pressure Washer KH200CI 15-200 50Hz

Hidrolimpiadora KH200CI 15-200 50Hz

Nettoyeuse haute Pression KH200CI 15-200 50Hz

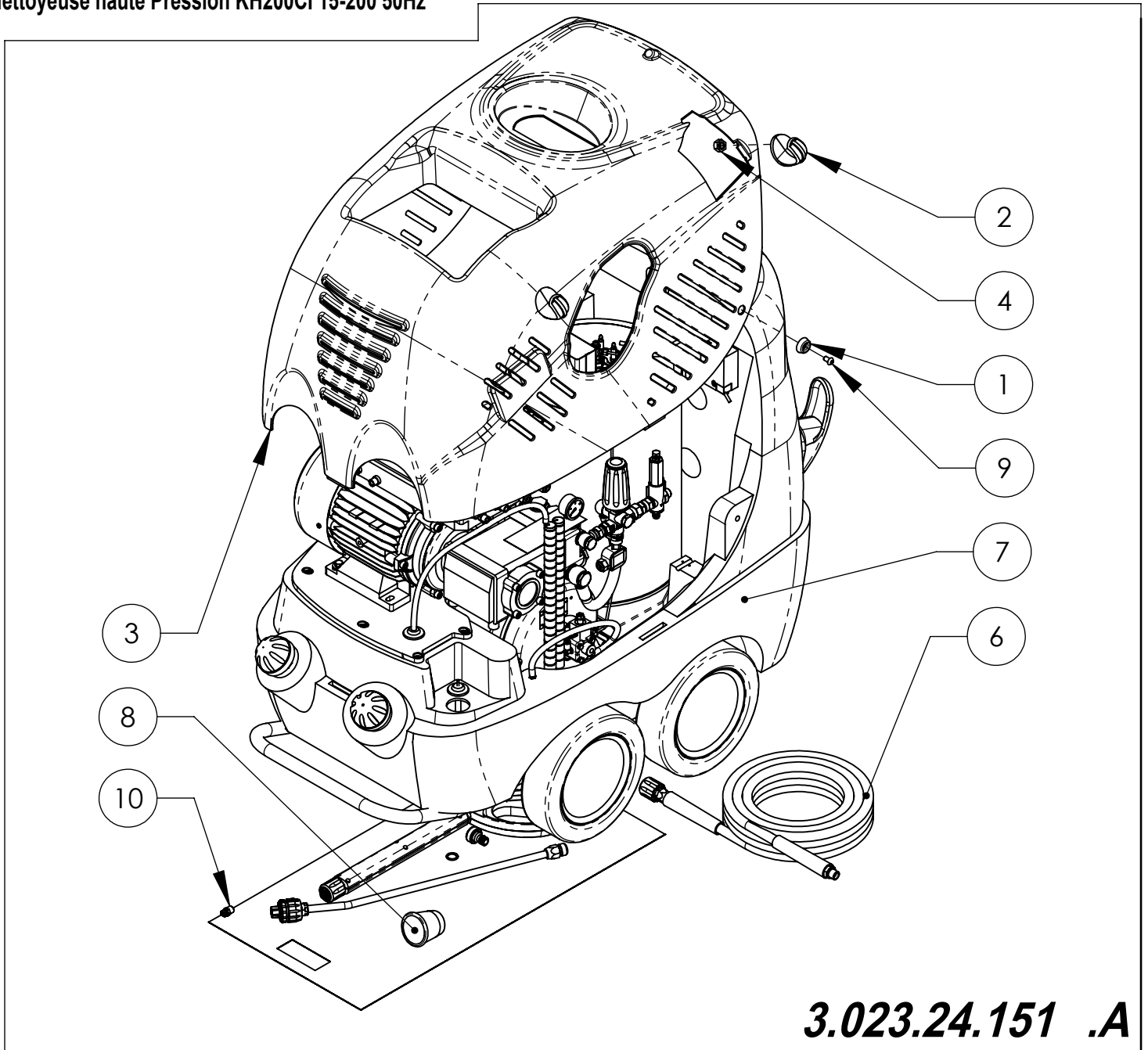

3.023.24.151 .A

3	1	1.014.14.048	Scocca rossa	Red cover	Rot abdeckung	Tapa rojo	Copot rouge
3	1	1.014.14.049	Scocca gialla	Yellow cover	Gelb abdeckung	Tapa jaune	Copot amarillo
3	1	1.014.14.052	Scocca verde	Green cover	Grün abdeckung	Tapa verde	Copot vert

Pos.	Q.tà	Cod.	ITALIANO	ENGLISH	DEUTSCH	ESPAÑOL	FRANCAIS
1	2	1.003.04.016	Rondella ø30	Washer ø30	Unterlegscheibe ø30	Arandela ø30	Rondelle ø30
2	2	1.011.04.049	Supporto porta lancia G1/4	lance holder G1/4	Lanzehalter G1/4	Sostenedor de la lanza G1/4	Support de lance G1/4
3	1	1.014.14.046	Scocca Blu	Blue Cover	Blauer Abdeckung	Tapa Azul	Copot Bleus
4	2	1.015.32.008	Ghiera G1/4"	Ferrule G1/4"	Zwinge G1/4"	Abrazadera G1/4"	Embout G1/4"
5	1	1.087.04.150	Etichetta	Label	Etikett	Etiqueta	Étiquette
6	1	2.006.24.038	Tubo 3/8 400Bar R2 10m M22 - G3/8-M	Pipe 3/8 400Bar R2 10m M22 - G3/8-M	Rohr 3/8 400Bar R2 10m M22 - G3/8-M	Tubo 3/8 400Bar R2 10m M22 - G3/8-M	Tuyau 3/8 400Bar R2 10m M22 - G3/8-M
7	1	2.049.24.075	Idro Premontato KH200CI	Preassembled idro KH200CI 15-200	Vormontierung idro KH200CI 15-200	Preensamblado idro KH200CI 15-200	Préassemblé idro KH200CI 15-200
8	1	3.045.04.002	15-200 BASIC Kit accessori K/PH2/3/3050	BASIC Accessories kit K/PH2/3/3050	BASIC Kit Zubehör K/PH2/3/3050	BASIC Kit accesorios K/PH2/3/3050	BASIC Kit accessoires K/PH2/3/3050
9	2	4.002.14.021	Vite M8x14 ISO7380	Screw M8x14 ISO7380	Schrauben M8x14 ISO7380	Tornillo M8x14 ISO7380	Vis M8x14 ISO7380
10	1	4.027.02.034	Ugello 15045	Nozzle 15045	Duse 15045	Boquilla 15045	Buse 15045

Idro Premontato KH200CI 15-200
Preassembled idro KH200CI 15-200
Vormontierung idro KH200CI 15-200
Preensablado idro KH200CI 15-200
Préassemblé idro KH200CI 15-200

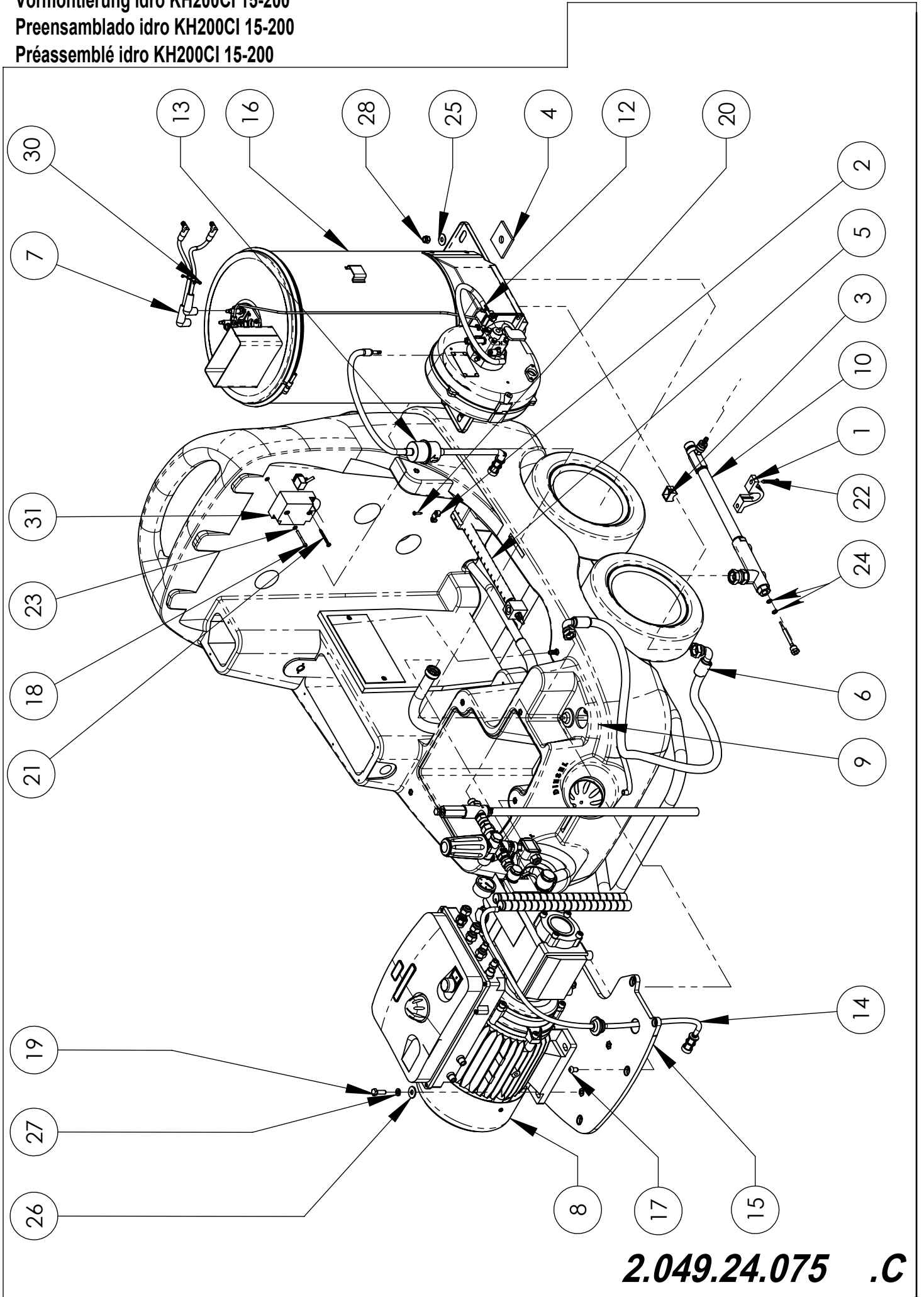

2.049.24.075 .C

Pos.	Q.tà	Cod.	ITALIANO	ENGLISH	DEUTSCH	ESPAÑOL	FRANCAIS
1	1	1.011.04.043	Supporto	Support	Halter	Soporte	Support
2	1	1.045.04.006	Fascetta ø11.3	Clamp ø11.3	Klemme ø11.3	Faja ø11.3	Petit bande ø11.3
3	1	1.081.04.001	Forcella	Fork	Gabel	Horquilla	Fourche
4	4	1.094.04.016	Isolante termico 55x55	Thermal insulator	Waermeschutzstoff	Aislador termal	Isolateur thermique
5	1	1.164.04.003	Guaina L=230	Insulator L=230	Isolator L=230	Aislador L=230	Isolateur L=230
6	1	2.006.24.065	Tubo TUBO 3\8 400B L950 3\8-1\2	Pipe TUBO 3\8 400B L950 3\8-1\2	Rohr TUBO 3\8 400B L950 3\8-1\2	Tubo TUBO 3\8 400B L950 3\8-1\2	Tuyau TUBO 3\8 400B L950 3\8-1\2
7	2	2.020.04.033	Cavo elettrodi	Electrodes cable	Elektrode kabel	Cable electrodos	Cable electrodos
8	1	2.034.04.054	Motopompa + Quadro elettrico KH200CI	Motorpump + Electric pannel KH200CI	Motorpumpe + Schalttafel KH200CI	Motobomba + Cuadro eléctrico KH200CI	Motopompe + Cadre électrique KH200CI
9	1	2.040.04.014	Serbatoio premontato KH200CI	Preassembled tank KH200CI	Vormontierung tank KH200CI	Preensamblado tanque KH200CI	Préassemblé réservoir KH200CI
10	1	2.048.04.006	Collettore KH200CI DBP	Collector KH200CI DBP	Kollektor KH200CI DBP	Colector KH200CI DBP	Collecteur KH200CI DBP
11	1	2.074.04.009	Tubo ø12xø17x540	Pipe ø12xø17x540	Rohr ø12xø17x540	Tubo ø12xø17x540	Tuyau ø12xø17x540
12	1	2.074.04.010	Tubo ø6xø9 L450	Pipe ø6xø9 L450	Rohr ø6xø9 L450	Tubo ø6xø9 L450	Tuyau ø6xø9 L450
13	1	2.074.04.011	Tubo aspirazione gasolio KH200CI	Gas oil suction pipe KH200CI	Saugrohr gas oel KH200CI	Tubo de aspiración gasoleo KH200CI	Tube d'aspiration gas oil KH200CI
14	1	2.074.04.016	Tubo aspirazione L1500	Suction pipe L1500	Saugrohr L1500	Tubo de aspiración L1500	Tube d'aspiration L1500
15	1	2.105.04.001	Piastra MEC112	Plate MEC112	Platte MEC112	Placa MEC112	Plat MEC112
16	1	3.026.04.035	Caldia 15L 50Hz KH200CI	Boiler 15L 50Hz KH200CI	Kessel 15L 50Hz KH200CI	Caldera 15L 50Hz KH200CI	Chaudière 15L 50Hz KH200CI
17	5	4.002.14.021	Vite M8x14 ISO7380	Screw M8x14 ISO7380	Schrauben M8x14 ISO7380	Tornillo M8x14 ISO7380	Vis M8x14 ISO7380
18	1	4.002.14.030	Vite M4x40 UNI 5931	Screw M4x40 UNI 5931	Schrauben M4x40 UNI 5931	Tornillo M4x40 UNI 5931	Vis M4x40 UNI 5931
19	4	4.002.44.014	Vite M8x25 UNI5739	Screw M8x25 UNI5739	Schrauben M8x25 UNI5739	Tornillo M8x25 UNI5739	Vis M8x25 UNI5739
20	2	4.002.92.001	Vite autofilettante 3.5x19	Self-tapping Screw 3.5x19	Selbschneidendeschraube 3.5x19	Tornillo autoblocante 3.5x19	Vis autofiletant 3.5x19
21	1	4.002.94.019	Vite autofilettante 3.9x45 AB D7982	Self-tapping Screw 3.9x45 AB D7982	Selbschneidendeschraube 3.9x45 AB D7982	Tornillo autoblocante 3.9x45 AB D7982	Vis autofiletant 3.9x45 AB D7982
22	2	4.002.94.027	Vite autofilettante 6.3X25 ISO7049	Self-tapping Screw 6.3X25 ISO7049	Selbschneidendeschraube 6.3X25 ISO7049	Tornillo autoblocante 6.3X25 ISO7049	Autofiletant 6.3X25 ISO7049
23	1	4.008.04.001	Rondella M4 UNI6592	Washer M4 UNI6592	Unterlegscheibe M4 UNI6592	Arandela M4 UNI6592	Rondelle M4 UNI6592
24	2	4.008.14.005	Rondella ø11.5x7.1x1	Washer ø11.5x7.1x1	Unterlegscheibe ø11.5x7.1x1	Arandela de cobre ø11.5x7.1x1	Rondelle ø11.5x7.1x1
25	2	4.008.22.001	Rondella M8 UNI6593	Washer M8 UNI6593	Unterlegscheibe M8 UNI6593	Arandela M8 UNI6593	Rondelle M8 UNI6593
26	4	4.008.24.002	Rondella ø8.5x24x2.5 6593	Washer ø8.5x24x2.5 6593	Unterlegscheibe ø8.5x24x2.5 6593	Arandela ø8.5x24x2.5 6593	Rondelle ø8.5x24x2.5 6593
27	4	4.008.54.004	Rondella di sicurezza UNI1751 M8	Safety washer UNI1751 M8	Sicherheits Scheibe UNI1751 M8	Arandela de seguridad UNI1751 M8	Rondelle de sûreté UNI1751 M8
28	2	4.009.14.001	Dado M8 UNI7473	Nut M8 UNI7473	Mutter M8 UNI7473	Dado M8 UNI7473	Ecrou M8 UNI7473
29	5	4.022.04.006	Fascetta 4.8x190	Clamp 4.8x190	Klemme 4.8x190	Faja 4.8x190	Petit bande 4.8x190
30	1	4.022.04.016	Fascetta 2x ø5.1/ø7.6	Clamp 2x ø5.1/ø7.6	Klemme 2x ø5.1/ø7.6	Faja 2x ø5.1/ø7.6	Petit bande 2x ø5.1/ø7.6
31	1	4.030.04.010	Trasformatore 20mA 230V	Transformer 20mA 230V	Stromwandler 20mA 230V	Transformador 20mA 230V	Transformateur 20mA 230V

Serbatoio premontato KH200CI
Preassembled tank KH200CI
Preensamblado tanque KH200CI
Vormontierung tank KH200CI
Préassemblé réservoir KH200CI

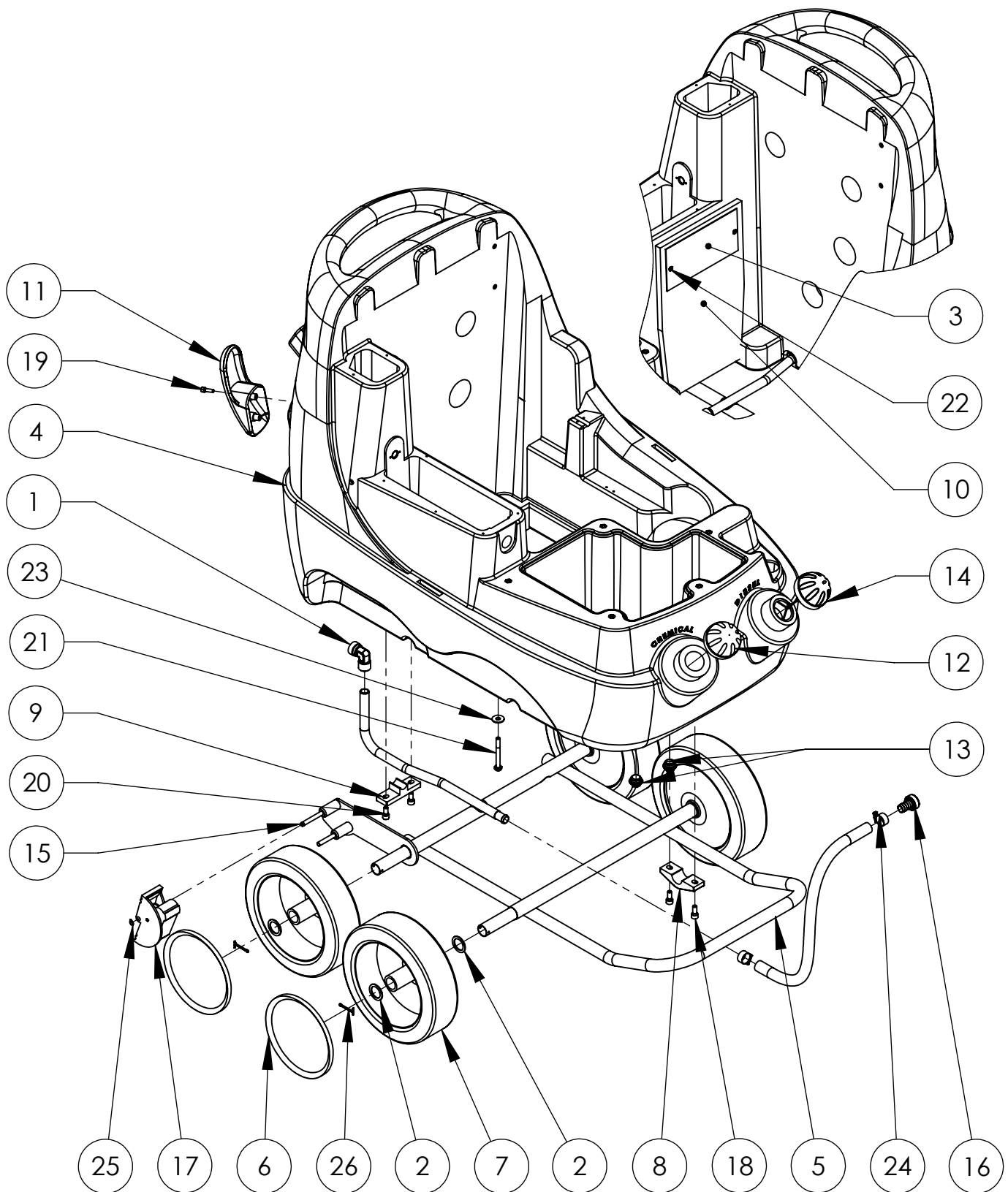

2.040.04.014 .F

Pos.	Q.à	Cod.	ITALIANO	ENGLISH	DEUTSCH	ESPAÑOL	FRANCAIS
1	1	1.001.14.013	Raccordo	Connection	Leiste	Filete	Filet
2	7	1.003.04.006	Rondella ø25.5xø35x2	Washer 25.5x35x2	Unterlegscheibe 25.5x35x2	Arandela 25.5x35x2	Rondelle 25.5x35x2
3	1	1.008.04.035	Piastra	Plate	Platte	Placa	Plat
4	1	1.033.04.016	Serbatoio KH200CI	Tank KH200CI	Tank KH200CI	Tanque KH200CI	Reservoir KH200CI
5	1	1.044.44.064	Tubo aspirazione ø16 L=650	Suction pipe ø16 L=650	Saugrohr ø16 L=650	Tubo de aspiración ø16 L=650	Tube d'aspiration ø16 L=650
6	2	1.085.04.015	Coprizzo	Hub Cap	Nabe Haus	Casquillo del cubo	Enjoliveur de roue
7	4	1.086.04.018	Ruota ø260 - ø25	Wheel ø260 - ø25	Rad ø260 - ø25	Rueda ø260 - ø25	Roue ø260 - ø25
8	4	1.089.04.023	Staffa	Stirrup	Buegel	Estribo	Étrier
9	1	1.089.04.034	Staffa	Stirrup	Buegel	Estribo	Étrier
10	1	1.094.04.023	Isolante termico (200x370)	Thermal insulator (200x370)	Waermeschutzstoff (200x370)	Aislador termal (200x370)	Isolateur thermique (200x370)
11	2	1.126.04.001	Gancio	Hook	Haken	Gancho	Crochet
12	1	2.013.04.013	Tappo grigio ø73	Grey cap ø73	Graue Kappe ø73	Casquillo Gris ø73	Couvercle gris ø73
13	2	2.013.04.020	Tappo 1/2 Gas	Plug 1/2 Gas	Deckel 1/2 Gas	Tapón 1/2 Gas	Bouchon 1/2 Gas
14	1	2.013.04.023	Tappo rosso	Red cap	Rote Kappe	Casquillo Rojo	Couvercle rouge
15	1	2.015.04.016	Telaio macchina KH200CI	Machine frame KH200CI	Maschinesrahmen KH200CI	Estructura máquina KH200CI	Chassis de la machine KH200CI
16	1	2.021.02.003	Attacco rapido	Quick coupling	Schnelle Kupplung	Ataque rapido	Connection rapide
17	1	2.052.04.002	Freno	Brake	Bremse	Freno	Frein
18	8	4.002.14.005	Vite M8x20 UNI5931	Screw M8x20 UNI5931	Schrauben M8x20 UNI5931	Tornillo M8x20 UNI5931	Vis M8x20 UNI5931
19	4	4.002.14.020	Vite M6x20 UNI5931	Screw M6x20 UNI5931	Schrauben M6x20 UNI5931	Tornillo M6x20 UNI5931	Vis M6x20 UNI5931
20	2	4.002.14.026	Vite M8X18 UNI 5931	Screw M8X18 UNI 5931	Schrauben M8X18 UNI 5931	Tornillo M8X18 UNI 5931	Vis M8X18 UNI 5931
21	2	4.002.44.009	Vite M8x70 UNI5737	Screw M8x70 UNI5737	Schrauben M8x70 UNI5737	Tornillo M8x70 UNI5737	Vis M8x70 UNI5737
22	2	4.002.94.030	Vite autofilettante UNI 6955 5x25 ZEB	Self-tapping Screw UNI 6955 5x25 ZEB	Selbschneidendeschraube UNI 6955 5x25 ZEB	Tornillo autoblocante UNI 6955 5x25 ZEB	Vis autofiletant UNI 6955 5x25 ZEB
23	2	4.008.24.002	Rondella ø8.5x24x2.5 6593	Washer ø8.5x24x2.5 6593	Unterlegscheibe ø8.5x24x2.5 6593	Arandela ø8.5x24x2.5 6593	Rondelle ø8.5x24x2.5 6593
24	2	4.022.04.020	Fascetta Ø16-27 H12 AISI304	Clamp Ø16-27 H12 AISI304	Klemme Ø16-27 H12 AISI304	Faja Ø16-27 H12 AISI304	Petit bande Ø16-27 H12 AISI304
25	1	4.025.04.009	Seeger A8 UNI 7435	Seeger A8 UNI 7435	Seeger A8 UNI 7435	Seeger A8 UNI 7435	Seeger A8 UNI 7435
26	4	4.044.04.004	Copiglia ø3.2x36 UNI1336	Spit-pin ø3.2x36 UNI1336	Splint ø3.2x36 UNI1336	Chaveta ø3.2x36 UNI1336	Goupille ø3.2x36 UNI1336

Kit accessori KH200CI

Accessories kit KH200CI

Kit accessoires KH200CI

Kit Zubehör KH200CI

Kit accessorios KH200CI

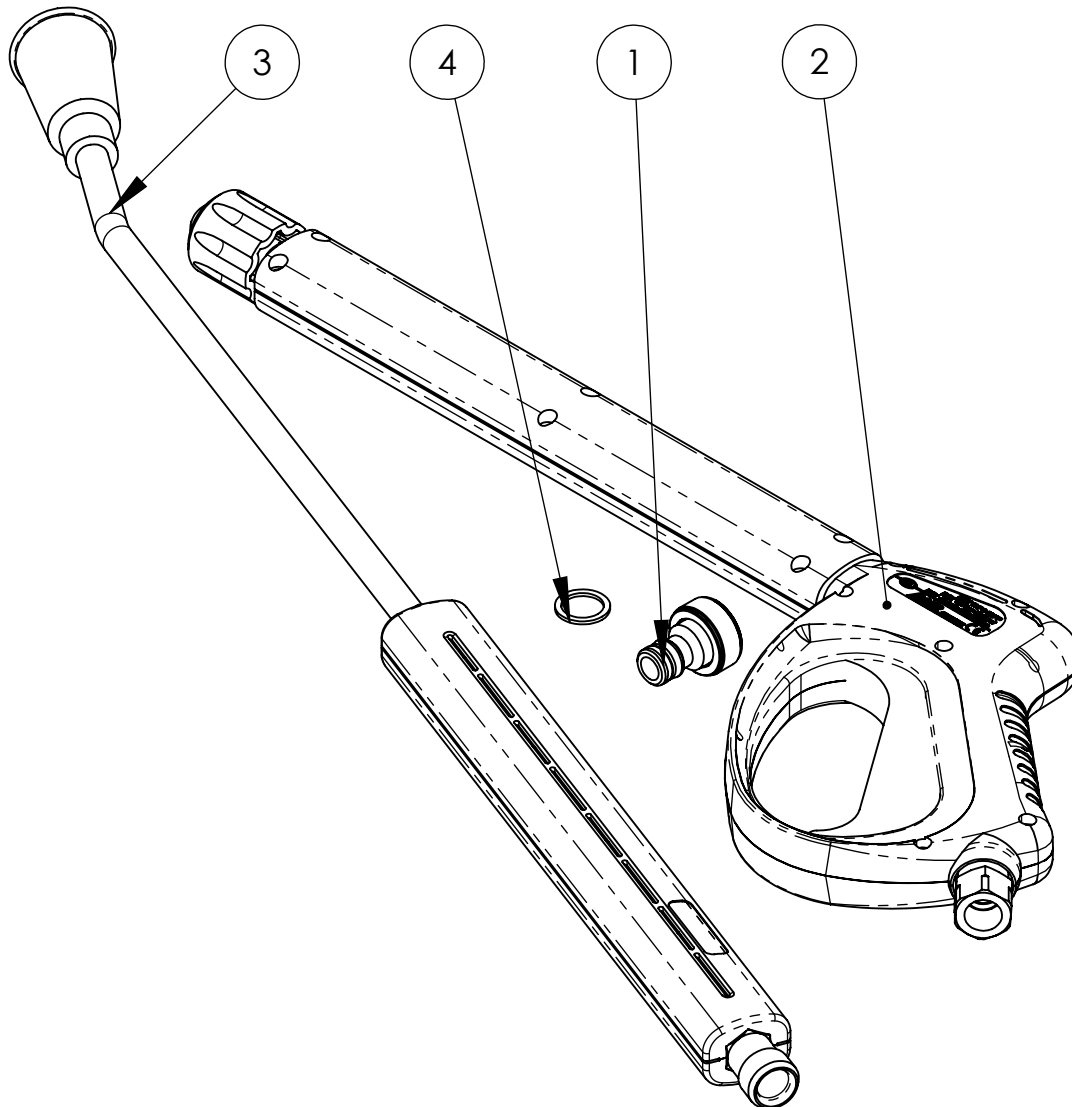

3.045.04.003 .A

Pos.	Q.tà	Cod.	ITALIANO	ENGLISH	DEUTSCH	ESPAÑOL	FRANCAIS
1	1	2.021.02.001	Innesto rapido	Quick coupling	Schnelle kupplung	Enchufe rapido	Raccord rapid
2	1	3.021.22.003	Pistola + Impugnatura "LASER" G3/8" F Sweevel	Trigger Gun + Grip "LASER" G3/8" F Sweevel	Pistole + Handgriff "LASER" G3/8" F Sweevel	Pistola + Empunadura "LASER" G3/8" F Sweevel	Pistolet + Branche "LASER" G3/8" F Sweevel
3	1	3.022.12.034	Lancia SC10 L=700 M22x1.5	Lance SC10 L=700 M22x1.5	Lanze SC10 L=700 M22x1.5	Lanza SC10 L=700 M22x1.5	Lance SC10 L=700 M22x1.5
4	1	4.008.12.001	Rondella Rame G3/8	Copper washer G3/8	Kupferunterlegsscheibe G3/8	Arandela de cobre G3/8	Rondelle cuivre G3/8

Caldaia 15L 50Hz KH200CI

Boiler 15L 50Hz KH200CI

Chaudière 15L 50Hz KH200CI

Kessel 15L 50Hz KH200CI

Caldera 15L 50Hz KH200CI

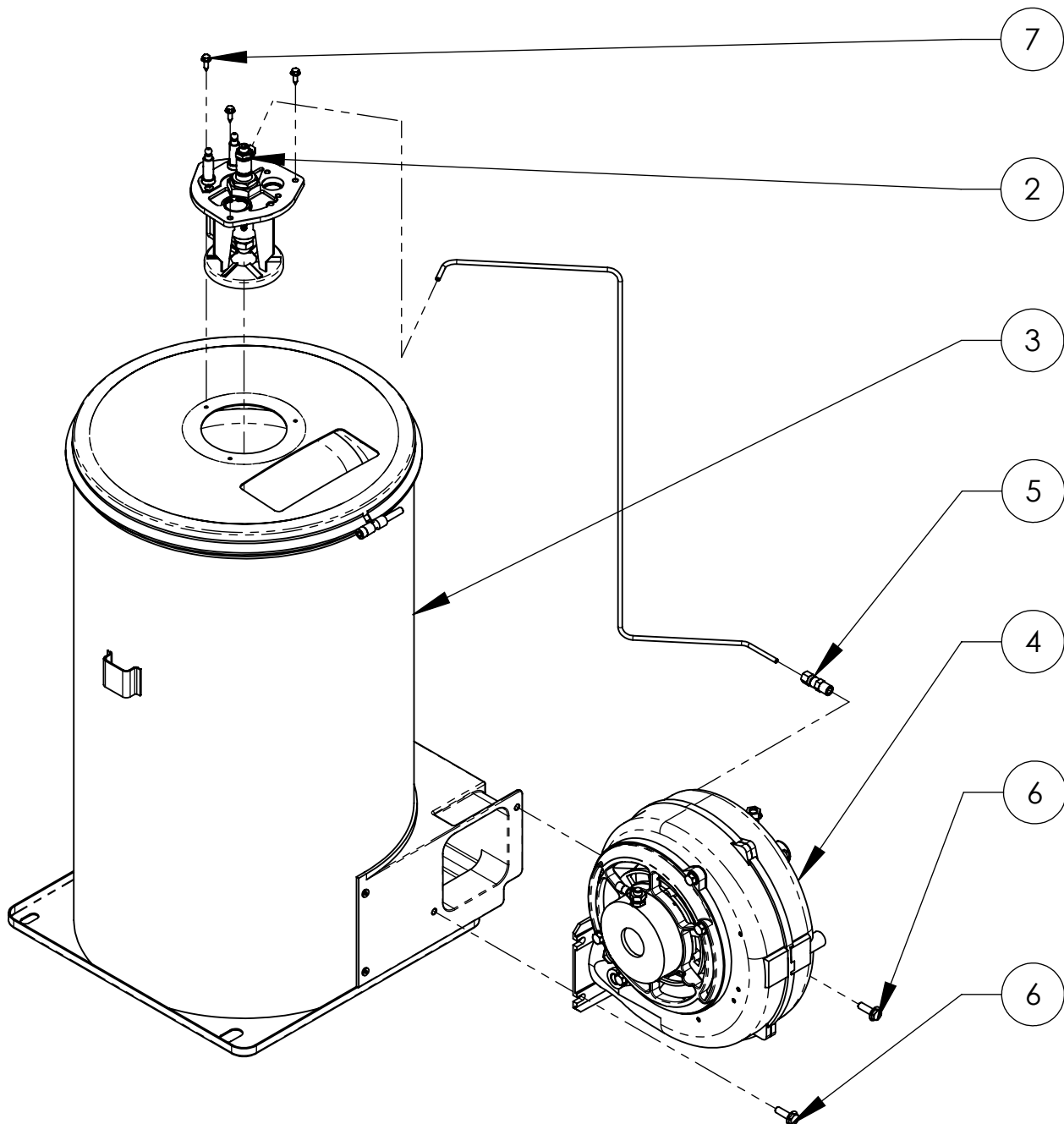

3.026.04.035 .C

Pos.	Q.tà	Cod.	ITALIANO	ENGLISH	DEUTSCH	ESPAÑOL	FRANCAIS
1	1	1.044.54.007	Tubo	Pipe	Rohr	Tubo	Tuyau
2	1	2.012.04.026	Coperchio elettrodi KH200CI	Electrodes cover KH200CI	Elektrodendeckel KH200CI	Tapòn electrodos KH200CI	Couvercle électrodes KH200CI
3	1	2.041.04.016	Caldaia	Boiler	Kessel	Caldera	Chaudière
4	1	3.038.02.019	Convogliatore 230V 1F2P50Hz SX KH200CI	Conveyor 230V 1F2P50Hz SX KH200CI	Foerderer 230V 1F2P50Hz SX KH200CI	Convoyador 230V 1F2P50Hz SX KH200CI	Convoyeur 230V 1F2P50Hz SX KH200CI
5	1	3.050.04.001	Raccordo	Connection	Leiste	Filete	Filet
6	2	4.002.92.011	Vite M6x20 UNI 8111	Screw M6x20 UNI 8111	Schrauben M6x20 UNI 8111	Tornillo M6x20 UNI 8111	Vis M6x20 UNI 8111
7	3	4.002.94.017	Vite autofilettante 3.9x13	Self-tapping Screw 3.9x13	Selbschneidendeschraube 3.9x13	Tornillo autoblocante 3.9x13	Vis autofiletant 3.9x13

Caldaja
Boiler **Kessel**
Chaudière **Caldera**

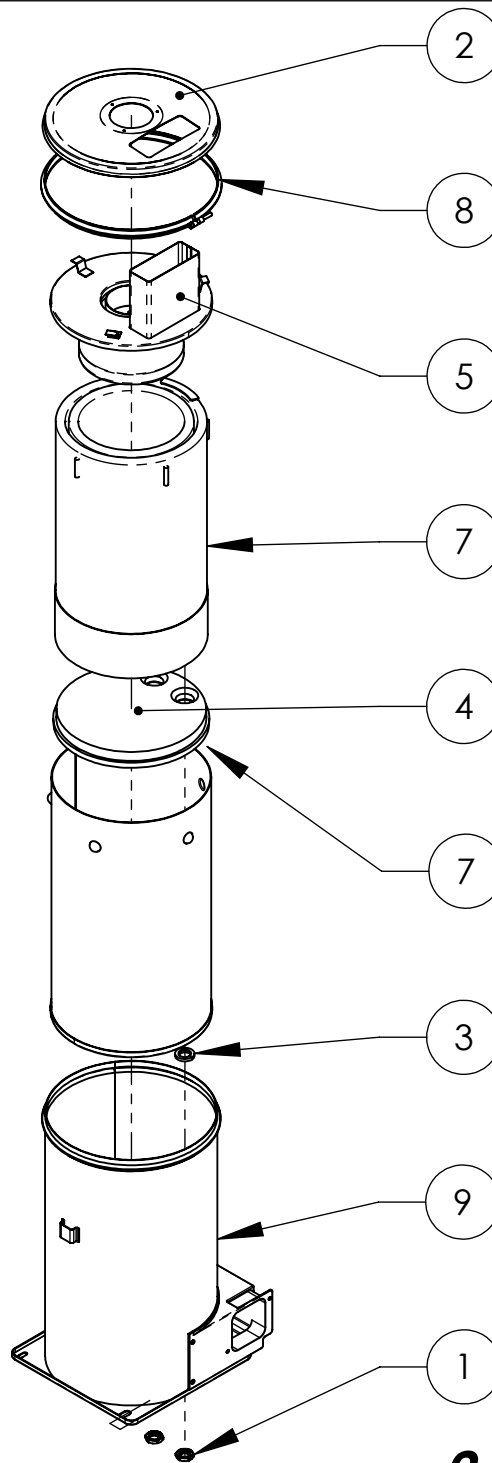

2.041.04.016 .D

<i>Pos.</i>	<i>Q.tà</i>	<i>Cod.</i>	<i>ITALIANO</i>	<i>ENGLISH</i>	<i>DEUTSCH</i>	<i>ESPAÑOL</i>	<i>FRANCAIS</i>
1	2	1.015.24.002	Ghiera	Ferrule	Zwinge	Abrazadera	Embout
2	1	1.054.04.006	Coperchio	Cover	Deckel	Tapa	Couvercle
3	2	1.060.04.018	Distanziale	Spacer	Distanzstueck	Distanciador	Entretoise
4	1	1.094.04.005	Isolante termico 20-25L	Thermal insulator 20-25L	Waermeschutzstoff 20-25L	Aislador termal 20-25L	Isolateur termique 20-25L
5	1	2.012.04.013	Coperchio W 20L	Cover W 20L	Deckel W 20L	Tapa W 20L	Couvercle W 20L
6	1	2.023.04.010	Camicia interna 25L	Internal jacket 25L	Innerer Mantel 25L	Camisa interior 25L	Chemise interne 25L
7	1	2.029.04.008	Serpentina 25L	Coil 25L	Schlange 25L	Serpentin 25L	Serpentin 25L
8	1	2.056.04.001	Fascetta ø317	Clamp ø317	Klemme ø317	Faja ø317	Petit bande ø317
9	1	2.111.04.002	Camicia esterna KH200Cl	External jacket KH200Cl	Äusserer Mantel KH200Cl	Camisa externa KH200Cl	Chemise externe KH200Cl

Coperchio elettrodi KH200CI

Electrodes cover KH200CI
Couvercle électrodes KH200CI

Elektrodendeckel KH200CI
Tapón electrodos KH200CI

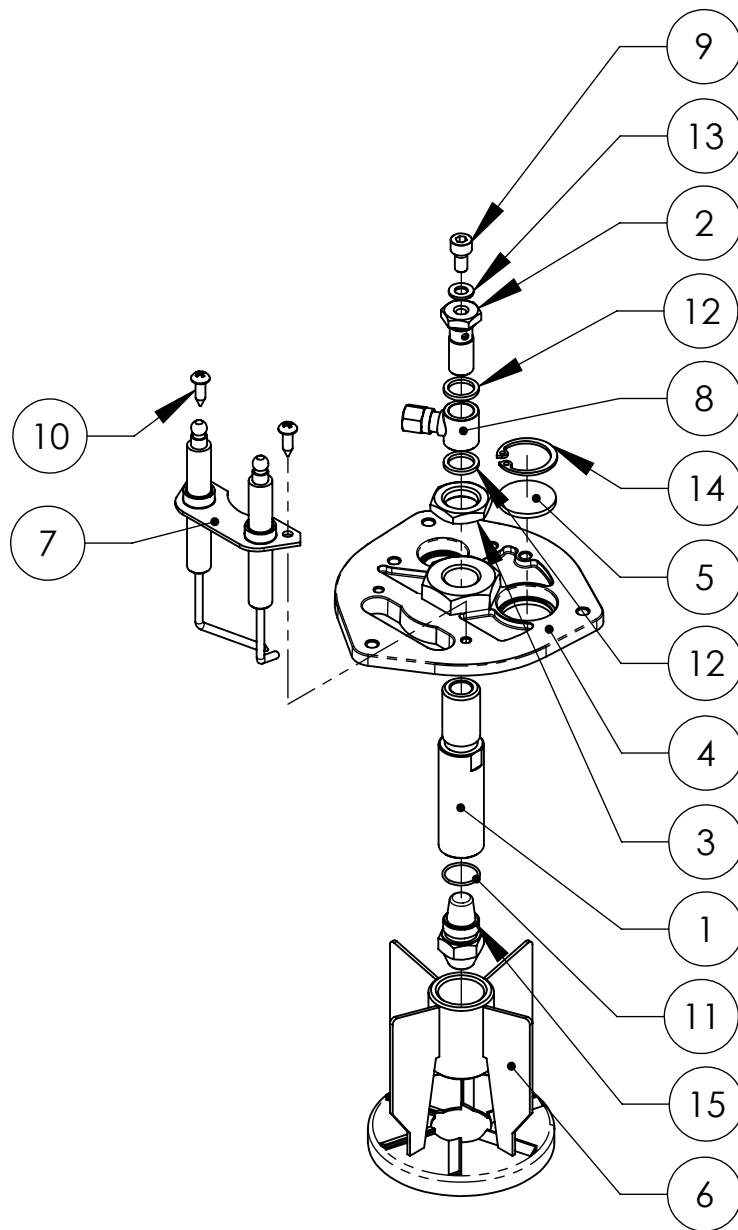

2.012.04.026 .C

Pos.	Q.ta	Cod.	ITALIANO	ENGLISH	DEUTSCH	ESPAÑOL	FRANCAIS
1	1	1.001.04.006	Raccordo 9/19 - G1/8	Connection 9/19 - G1/8	Leiste 9/19 - G1/8	Filete 9/19 - G1/8	Filet 9/19 - G1/8
2	1	1.012.14.012	Tappo FORATO G1/8+CONTR.PRESS.M5	Cap FORATO G1/8+CONTR.PRESS.M5	Deckel FORATO G1/8+CONTR.PRESS.M5	Tapón FORATO G1/8+CONTR.PRESS.M5	Bouchon FORATO G1/8+CONTR.PRESS.M5
3	1	1.015.24.003	Ghiera	Ferrule	Zwinge	Abrazadera	Embout
4	1	1.074.04.011	Flangia	Flange	Flansch	Borde	Bride
5	1	1.102.04.001	Vetrino	Glass	Glass	Vidrio	Vèrre
6	1	2.009.04.002	Deflettore Work	Deflector Work	Deflektor Work	Deflector Work	Défecteur Work
7	1	2.032.04.004	Elettrodi	Electrodes	Elektrode	Electrodos	Electrodes
8	1	3.050.34.001	Raccordo	Connection	Leiste	Filete	Filet
9	1	4.002.14.022	Vite M5x10 UNI5931	Screw M5x10 UNI5931	Schrauben M5x10 UNI5931	Tornillo M5x10 UNI5931	Vis M5x10 UNI5931
10	2	4.002.94.005	Vite autofilettante 3.9x13	Self-tapping Screw 3.9x13	Gewindeschneidschraube 3.9x13	Tornillo Self-tapping 3.9x13	Vies Autofilettante 3.9x13
11	1	4.005.14.004	OR 0130-1	O-ring 0130-1	O-ring 0130-1	OR 0130-1	Joint torique 0130-1
12	2	4.008.12.005	Rondella Rame G1/8	Copper washer G1/8	Kupferunterlegsscheibe G1/8	Arandelade cobre G1/8	Rondelle cuivre G1/8
13	1	4.008.14.003	Rondella Rame M5	Copper washer M5	Kupferunterlegsscheibe M5	Arandela de cobre M5	Rondelle cuivre M5
14	1	4.025.04.002	Seeger	Seeger	Seeger	Seeger	Seeger
15	1	4.027.14.002	Ugello 1.50 (60°S)	Nozzle 1.50 (60°S)	Duse 1.50 (60°S)	Boquilla 1.50 (60°S)	Buse 1.50 (60°S)

Convogliatore 230V 1F2P50Hz SX KH200CI

Conveyor 230V 1F2P50Hz SX KH200CI

Foerderer 230V 1F2P50Hz SX KH200CI

Convoyeur 230V 1F2P50Hz SX KH200CI

Convoyador 230V 1F2P50Hz SX KH200CI

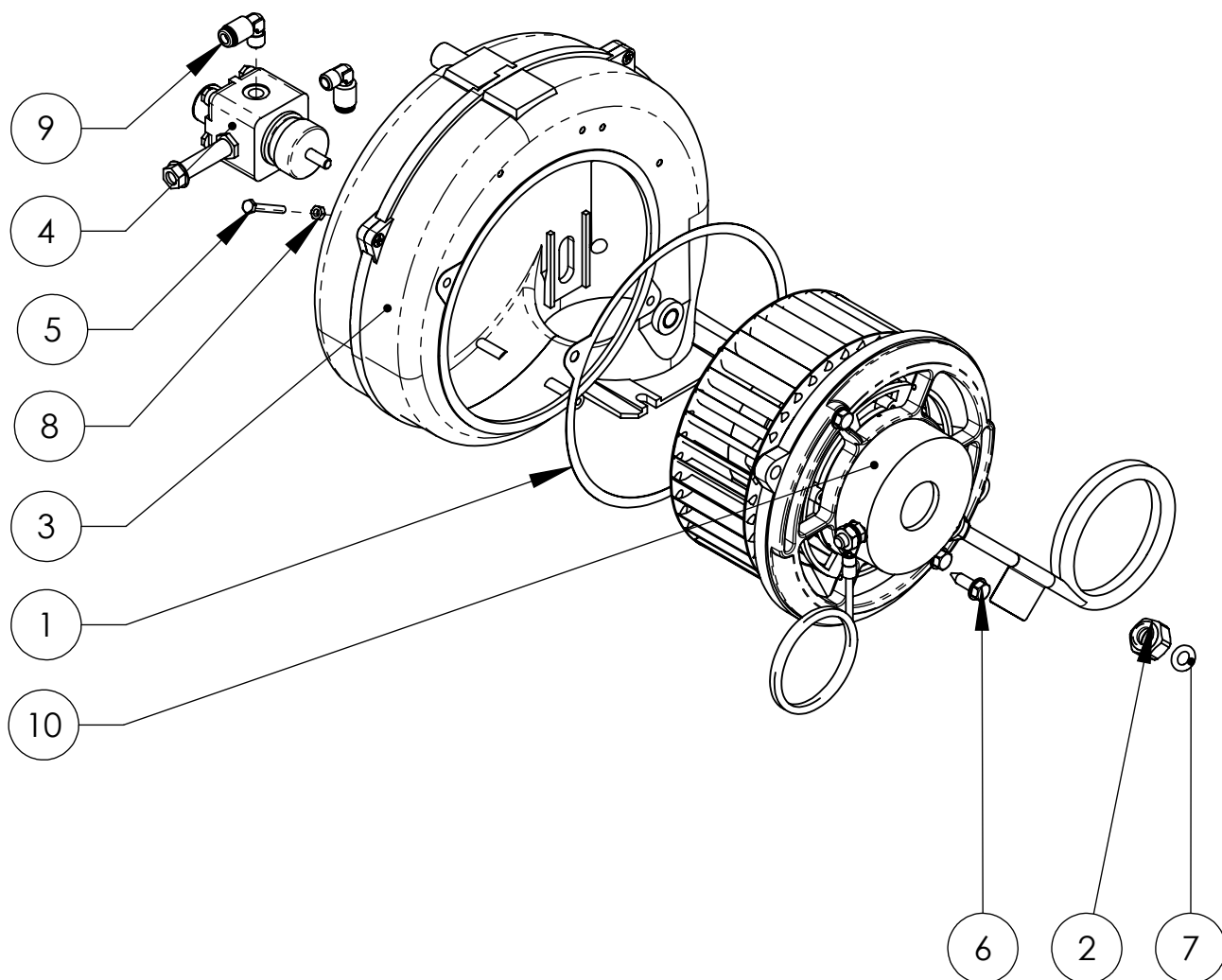

3.038.02.019 .A

Pos.	Q.tà	Cod.	ITALIANO	ENGLISH	DEUTSCH	ESPAÑOL	FRANCAIS
1	1	1.006.22.002	Guarnizione	Gasket	Dichtung	Guarnición	Garniture
2	1	1.015.32.011	Ghiera	Ferrule	Zwinge	Abrazadera	Embout
3	1	2.017.22.001	Carter Montato	Assembled Guard	Montiertes Gehäuse	Ensamblado Carter	Carter assemblé
4	1	3.015.24.006	Pompa gasolio	Diesel pump	Heizölpumpe	Bomba gasóleo	Pompe gasoil
5	3	4.002.44.012	Vite M4x30 UNI5739	Screw M4x30 UNI5739	Schrauben M4x30 UNI5739	Tornillo M4x30 UNI5739	Vis M4x30 UNI5739
6	2	4.002.94.012	Vite autofilettante 6.3x20 AB 6950	Self-tapping Screw 6.3x20 AB 6950	Selbschneidendeschraube 6.3x20 AB 6950	Tornillo autobloccante 6.3x20 AB 6950	Vis autofiletant 6.3x20 AB 6950
7	1	4.005.22.028	OR 0080-35	O-ring 0080-35	O-ring 0080-35	OR 0080-35	Joint torique ORM 0080-35
8	3	4.009.02.006	Dado M4 UNI5588	Nut M4 UNI5588	Mutter M4 UNI5588	Dado M4 UNI5588	Ecrou M4 UNI5588
9	2	4.012.04.013	Raccordo a L G1/4	L Connection G1/4	Leiste L G1/4	Filete L G1/4	Filet L G1/4
10	1	9.014.02.006	Motore Elettrico 230V 50Hz	Electric Motor 230V 50Hz	Elektromotor 230V 50Hz	Motor Eléctrico 230V 50Hz	Moteur électrique 230V 50Hz

Motopompa + Quadro elettrico KH200CI
Motorpump + Electric pannel KH200CI
Motorpumpe + Schalttafel KH200CI
Motobomba + Cuadro eléctrico KH200CI
Motopompe + Cadre électrique KH200CI

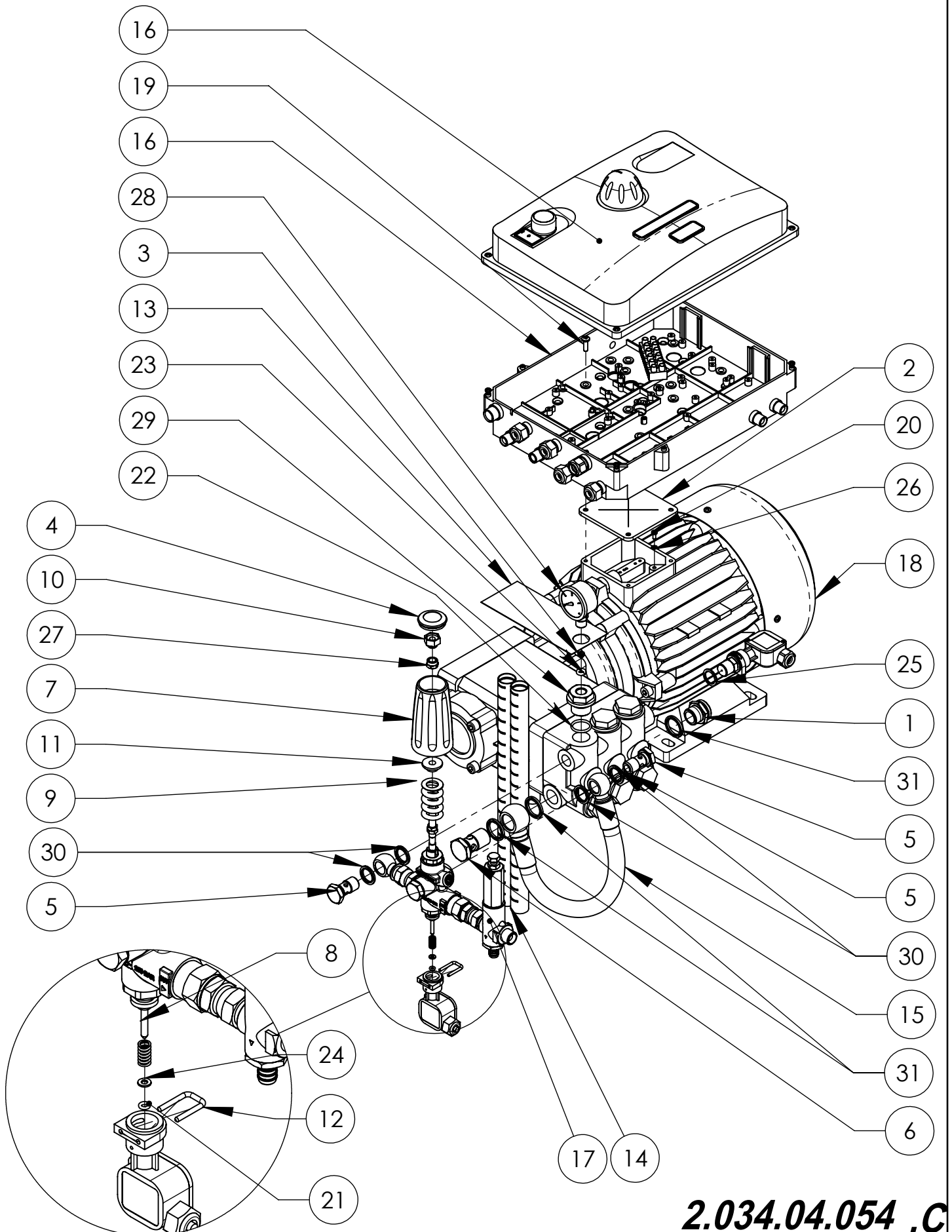

2.034.04.054 .C

Pos.	Q.tà	Cod.	ITALIANO	ENGLISH	DEUTSCH	ESPAÑOL	FRANCAIS
1	1	1.001.02.007	Raccordo G3/4 - G1/2	Connection G3/4 - G1/2	Leiste G3/4 - G1/2	Filete G3/4 - G1/2	Filet G3/4 - G1/2
2	1	1.006.14.005	Guarnizione 86x86	Gasket 86x86	Dichtung 86x86	Guarnición 86x86	Garniture 86x86
3	1	1.007.24.003	Otturatore	Shutter	Obturator	Verschluss	Obturateur
4	1	1.012.02.005	Tappo	Cap	Deckel	Tapón	Bouchon
5	2	1.012.14.003	Tappo 3/8	Cap 3/8	Deckel 3/8	Tapón 3/8	Bouchon 3/8
6	1	1.012.14.004	Tappo G1/2	Cap G1/2	Deckel G1/2	Tapón G1/2	Bouchon G1/2
7	1	1.021.02.012	Manopla	Knob	Griff	Pomo	Poignée
8	1	1.025.12.010	Molla P115	Spring P115	Feder P115	Muelle P115	Ressort P115
9	1	1.025.22.001	Molla Blu	Blue Spring	Blauer Feder	Muelle Azul	Ressort Bleus
10	1	1.036.02.001	Inserto M8	Insert M8	Einsatz M8	Inserto M8	Insert M8
11	1	1.072.02.004	Premimolla	Spring clamp	Federdrücker	Prensamuelle	Presse-ressort
12	1	1.081.02.001	Forcella	Fork	Gabel	Horquilla	Fourche
13	1	1.087.04.283	Etichetta	Label	Etiket	Etiqueta	Étiquette
14	2	1.164.04.004	Guaina	Insulator	Isolator	Aislador	Isolateur
15	1	2.006.24.009	Tubo 40Bar L300	Pipe 40Bar L300	Rohr 40Bar L300	Tubo 40Bar L300	Tuyau 40Bar L300
16	1	2.031.04.149	Quadro elettrico KH200CI	Electric pannel KH200CI	Schalltafel KH200CI	Cuadro eléctrico KH200CI	Cadre électrique KH200CI
17	1	2.100.04.004	Gruppo valvola KH200C	Valve Unit KH200CI	Vantflagggregat KH200CI	Ensemble clapet KH200CI	Grupo Válvula KH200CI
18	1	3.006.12.059	Motopompa 400V 50Hz HC506	Motorpump 400V 50Hz HC506	Motorpumpe 400V 50Hz HC506	Motobomba 400V 50Hz HC506	Motopompe 400V 50Hz HC506
19	1	4.002.72.008	Vite M5x16 UNI 7687-77	Screw M5x16 UNI 7687-77	Schrauben M5x16 UNI 7687-77	Tornillo M5x16 UNI 7687-77	Vis M5x16 UNI 7687-77
20	1	4.002.94.016	Vite M3.5x8 UNI8112	Screw M3.5x8 UNI8112	Schrauben M3.5x8 UNI8112	Tornillo M3.5x8 UNI8112	Vis M3.5x8 UNI8112
21	1	4.005.22.003	OR 2015	O-ring 2015	O-Ring 2015	OR 2015	Joint torique 2015
22	1	4.005.22.026	OR 3081	O-ring 3081	O-Ring 3081	OR 3081	Joint torique 3081
23	1	4.005.24.013	Guarnizione OR ø4.34X3.53	Gasket OR ø4.34X3.53	Dichtung OR ø4.34X3.53	Guarnición OR ø4.34X3.53	Garniture OR ø4.34X3.53
24	1	4.008.02.002	Rondella ø4.3xø8x0.5 (OT)	Washer ø4.3xø8x0.5 (OT)	Unterlegscheibe ø4.3xø8x0.5 (OT)	Arandela M4.3xø8x0.5 (OT)	Rondelle ø4.3xø8x0.5 (OT)
25	1	4.008.12.001	Rondella Rame G3/8	Copper washer G3/8	Kupferunterlegsscheibe G3/8	Arandela de cobre G3/8	Rondelle cuivre G3/8
26	1	4.008.54.001	Rondella di sicurezza UNI8842 M4	Safety washer UNI8842 M4	Sicherheits Scheibe UNI8842 M4	Arandela de seguridad UNI8842 M4	Rondelle de sûreté UNI8842 M4
27	1	4.009.12.001	Dado M8 UNI7474	Nut M8 UNI7474	Mutter M8 UNI7474	Dado M8 UNI7474	Ecrou M8 UNI7474
28	1	4.020.04.006	Manometro 0-300Bar G1/4 ø40	Pressure gauge 0-300Bar G1/4 ø40	Druckmesser 0-300Bar G1/4 ø40	Manómetro 0-300Bar G1/4 ø40	Manomètre 0-300Bar G1/4 ø40
29	1	4.036.04.005	Tappo M24x1.5 / G1/4	Cap M24x1.5 / G1/4	Deckel M24x1.5 / G1/4	Tapón M24x1.5 / G1/4	Bouchon M24x1.5 / G1/4
30	4	4.070.04.001	Guarnizione G3/8	Gasket G3/8	Dichtung G3/8	Guarnición G3/8	GarnitureG3/8
31	3	4.070.04.002	Guarnizione G1/2	Gasket G1/2	Dichtung G1/2	Guarnición G1/2	GarnitureG1/2

Gruppo valvola KH200CI

Valve Unit KH200CI
Grupo Válvula KH200CI

Vantlaggregat KH200CI
Ensemble clapet KH200CI

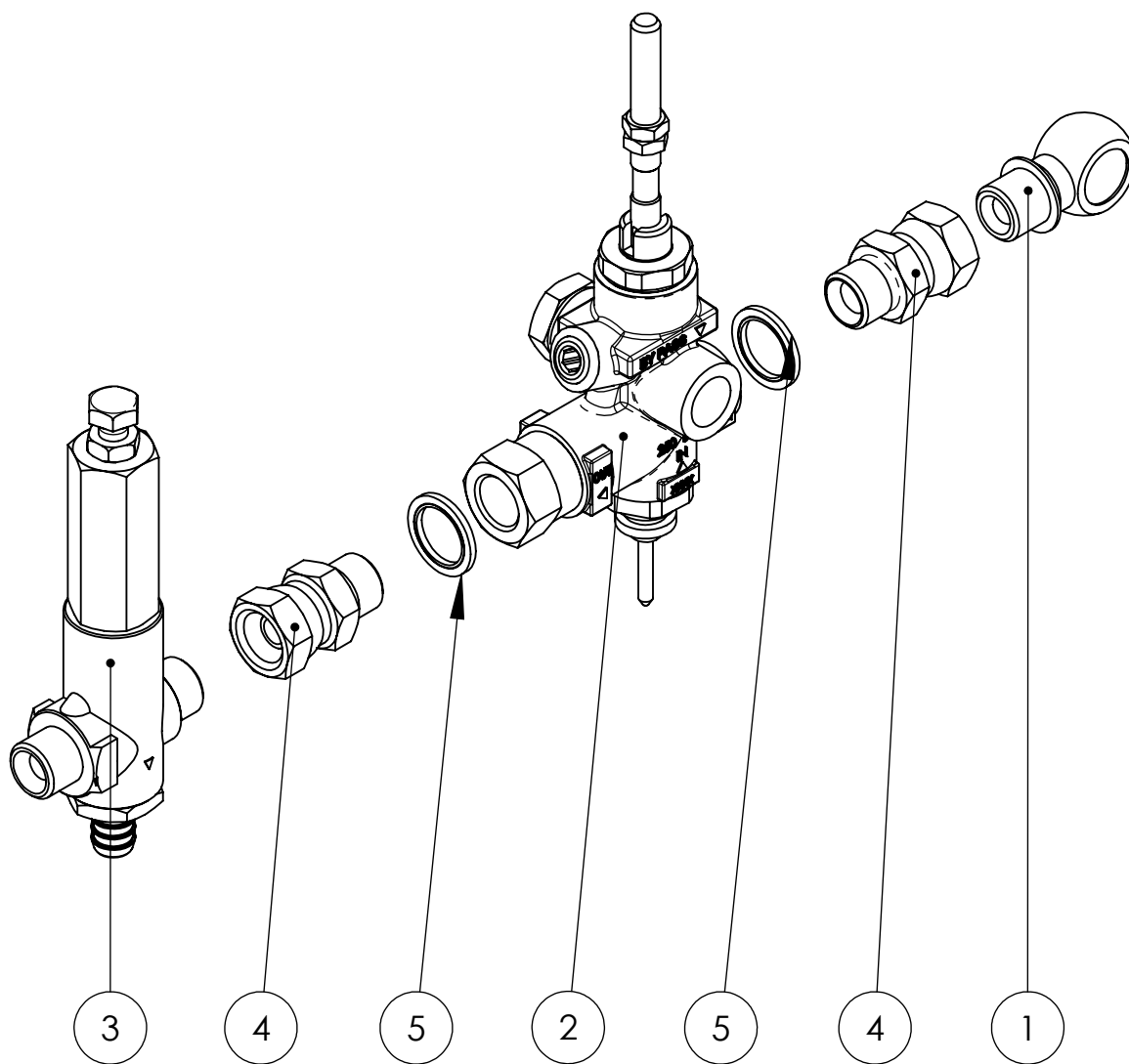

2.100.04.004 .C

<i>Pos.</i>	<i>Q.ta</i>	<i>Cod.</i>	<i>ITALIANO</i>	<i>INGLESE</i>	<i>DEUTSCH</i>	<i>ESPAÑOL</i>	<i>FRANCAIS</i>
1	1	1.001.34.008	Raccordo G3/8 L33	Connection G3/8 L33	Leiste G3/8 L33	Filete G3/8 L33	Filet G3/8 L33
2	1	2.003.34.014	Valvola di regolazione Pressione G3/8 F-F (TS)	Pressure unloader valve G3/8 F-F (TS)	Druckregelventile G3/8 F-F (TS)	Válvula reguladores de presion G3/8 F-F (TS)	Valve regulateur de presion G3/8 F-F (TS)
3	1	3.003.22.005	Valvola di sicurezza G3/8 MM	Safety pressure valve G3/8 MM	Max druck Einstellungsventile G3/8 MM	Valvula de seguridad G3/8 MM	Soupage de presion maximal G3/8 MM
4	2	4.012.04.002	Raccordo G3/8	Connection G3/8	Leiste G3/8	Filete G3/8	Filet G3/8
5	2	4.070.04.001	Guarnizione G3/8	Gasket G3/8	Dichtung G3/8	Guarnición G3/8	Garniture G3/8

Valvola di regolazione Pressione G3/8 F-F (TS)

Pressure unloader valve G3/8 F-F (TS)

Druckregelventile G3/8 F-F (TS)

Valve regulateur de pression G3/8 F-F (TS)

Válvula reguladores de presión G3/8 F-F (TS)

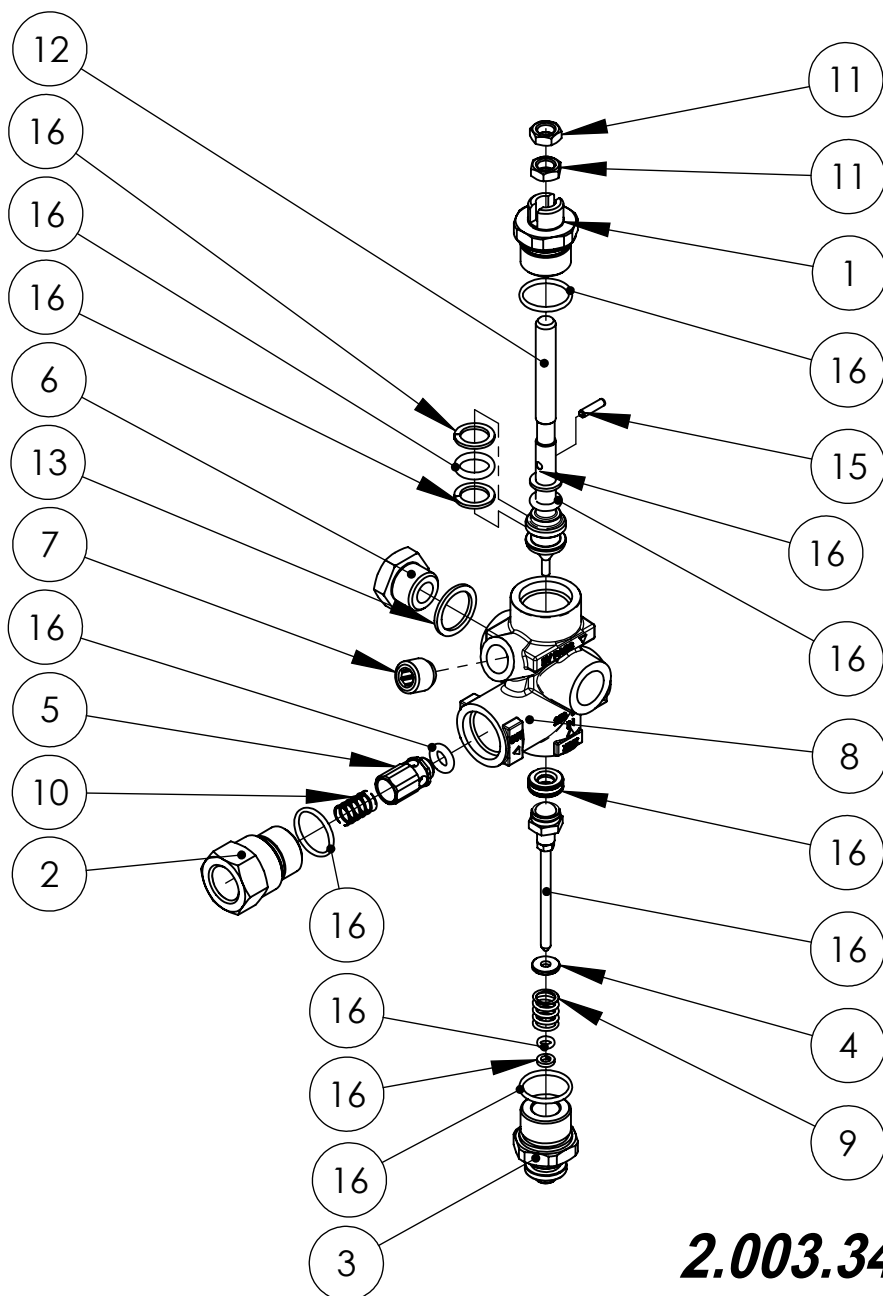

2.003.34.014 .F

Pos.	Q.tà	Cod.	ITALIANO	ENGLISH	DEUTSCH	ESPAÑOL	FRANCAIS
1	1	1.001.02.002	Raccordo M20x3/8	Connection M20x3/8	Leiste M20x3/8	Filete M20x3/8	Filet M20x3/8
2	1	1.001.02.003	Raccordo Entrata M20x1.5 - G3/8"	Intake connection M20x1.5 - G3/8"	Eingangsverbindung M20x1.5 - G3/8"	Racor entrada M20x1.5 - G3/8"	Raccord d'entrée M20x1.5 - G3/8"
3	1	1.001.02.024	Raccordo	Connection	Leiste	Filete	Filet
4	1	1.003.02.004	Rondella ø4x11x1.5	Washer ø4x11x1.5	Unterlegscheibe ø4x11x1.5	Arandela ø4x11x1.5	Rondelle ø4x11x1.5
5	1	1.007.02.001	Otturatore	Shutter	Obturador	Verschluss	Obturateur
6	1	1.012.12.001	Tappo G3/8"	Cap G3/8"	Deckel G3/8"	Tapón G3/8"	Bouchon G3/8"
7	1	1.012.42.002	Tappo G1/4	Cap G1/4	Deckel G1/4	Tapón G1/4	Bouchon G1/4
8	1	1.020.22.004	Corpo VBR	Body VBR	Körper VBR	Cuerpo VBR	Corps VBR
9	1	1.025.12.002	Molla 15x1.4	Spring 15x1.4	Feder 15x1.4	Muelle 15x1.4	Ressort 15x1.4
10	1	1.025.12.003	Molla ø0.7xøe9xh21	Spring ø0.7xøe9xh21	Feder ø0.7xøe9xh21	Muelle ø0.7xøe9xh21	Ressort ø0.7xøe9xh21
11	2	1.035.02.001	Dado M8	Nut M8	Mutter M8	Dado M8	Ecrou M8
12	1	1.037.02.001	Stelo VRB	Stem VRB	Spindel VRB	Vastago VRB	Tige VRB
13	1	4.008.12.001	Rondella Rame G3/8	Copper washer G3/8	Kupferunterlegsscheibe G3/8	Arandela de cobre G3/8	Rondelle cuivre G3/8
14	1	4.008.12.003	Rondella Rame G1/4	Copper washer G1/4	Kupferunterlegsscheibe G1/4	Arandela de cobre G1/4	Rondelle cuivre G1/4
15	1	4.011.12.001	Spina	Plug	Stecker	Enchufe	Prise
16	1	9.003.02.007	Kit Tenute TOTALSTOP	Spare seals kit TOTALSTOP	Kit Dichtungen TOTALSTOP	Kit cierres TOTALSTOP	Kit joints détanchéité TOTALSTOP

Valvola di sicurezza G3/8 MM

Safety pressure valve G3/8 MM

Max druck Einstellungsventile G3/8 MM

Soupape de pression maximal G3/8 MM

Válvula de seguridad G3/8 MM

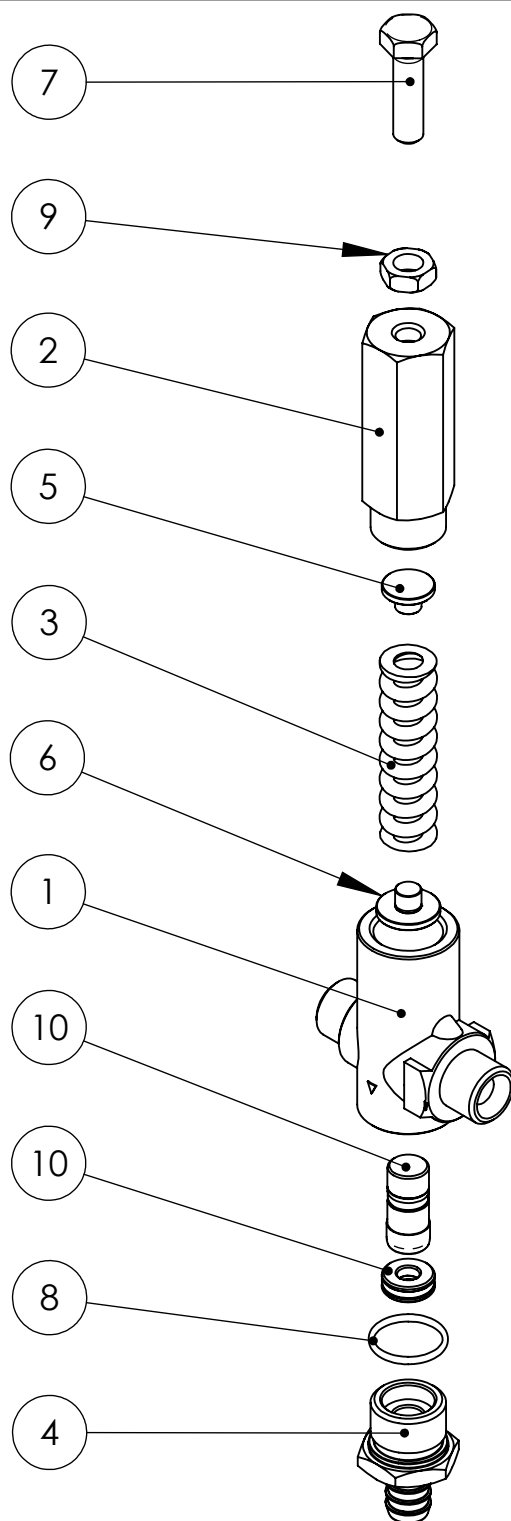

3.003.22.005 .B

<i>Pos.</i>	<i>Q.tà</i>	<i>Cod.</i>	<i>ITALIANO</i>	<i>ENGLISH</i>	<i>DEUTSCH</i>	<i>ESPAÑOL</i>	<i>FRANCAIS</i>
1	1	1.020.22.021	Corpo G3/8-MM	Body G3/8-MM	Körper G3/8-MM	Cuerpo G3/8-MM	Corps G3/8-MM
2	1	1.021.02.011	Manopola Valvola di sicurezza	Safety pressure valve Knobs	Max druck Einstellungsventile Griff	Pomo Valvula de seguridad	Poignée de Soupape de pression maximal
3	1	1.025.22.007	Molla ø15.6 - F=3.8 - L=57	Spring ø15.6 - F=3.8 - L=57	Feder ø15.6 - F=3.8 - L=57	Muelle ø15.6 - F=3.8 - L=57	Ressort ø15.6 - F=3.8 - L=57
4	1	1.049.02.007	Portagomma ø12xM20x1.5 M	Hose fitting ø12xM20x1.5 M	Schlauchhalter ø12xM20x1.5 M	Portamanguera ø12xM20x1.5 M	Raccord pour tuyau ø12xM20x1.5 M
5	1	1.072.02.011	Premimolla	Spring clamp	Federdrücker	Prensamuelle	Presse-ressort
6	1	1.072.02.012	Premimolla	Spring clamp	Federdrücker	Prensamuelle	Presse-ressort
7	1	4.002.42.003	Vite M8x30 UNI5739	Screw M8x30 UNI5739	Schrauben M8x30 UNI5739	Tornillo M8x30 UNI5739	Vis M8x30 UNI5739
8	1	4.005.21.011	OR 2068	O-ring 2068	O-ring 2068	OR 2068	Joint torique 2068
9	1	4.009.04.003	Dado M8 UNI5589	Nut M8 UNI5589	Mutter M8 UNI5589	Dado M8 UNI5589	Ecrou M8 UNI5589
10	1	9.005.02.004	Kit Tenute	Spare seals kit	Kit Dichtungen	Kit cierres	Kit joints détachéité

Quadro elettrico KH200CI

Electric pannel KH200CI

Cadre électrique KH200CI

Schalttafel KH200CI

Cuadro eléctrico KH200CI

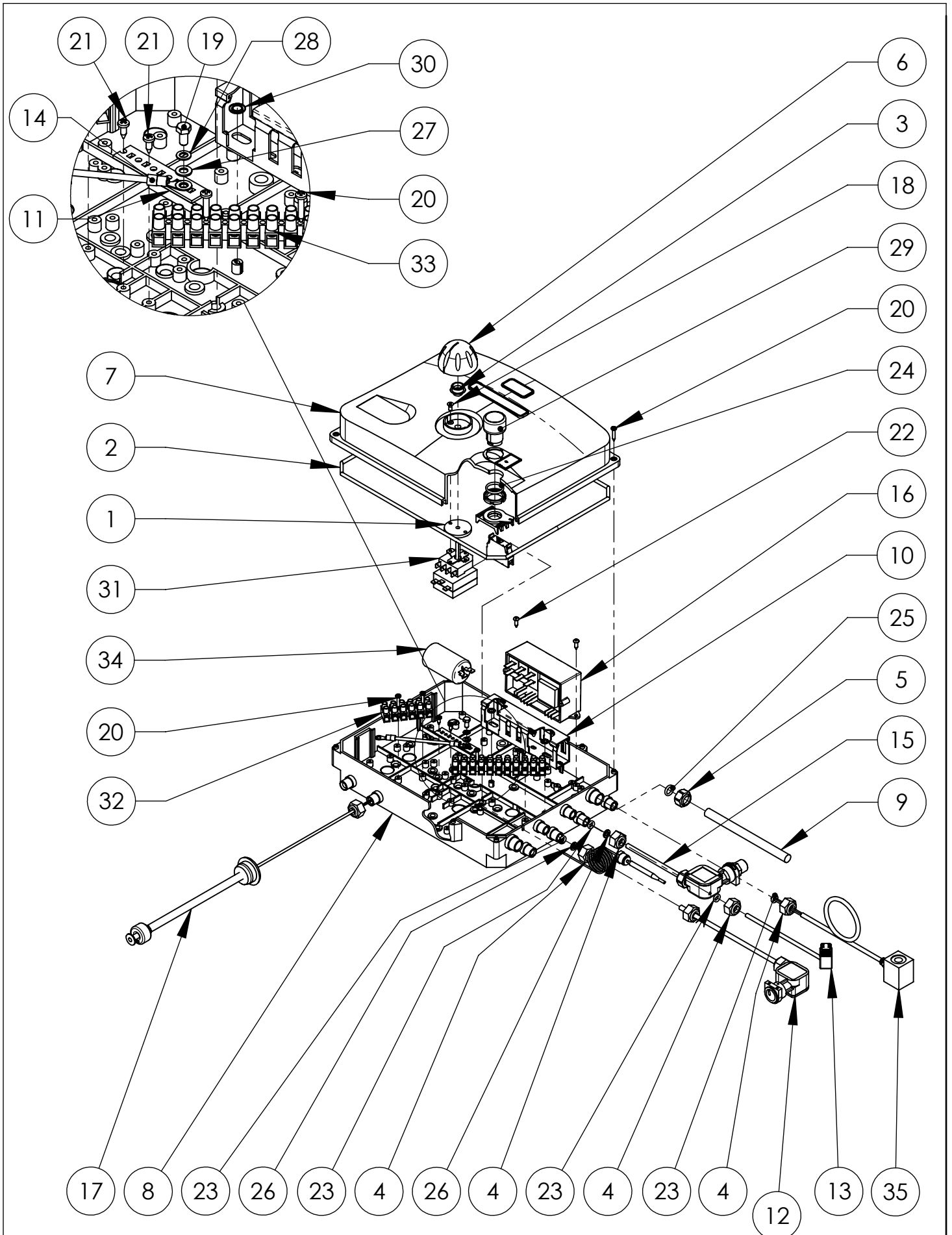

<i>Pos.</i>	<i>Q.tà</i>	<i>Cod.</i>	<i>ITALIANO</i>	<i>ENGLISH</i>	<i>DEUTSCH</i>	<i>ESPAÑOL</i>	<i>FRANCAIS</i>
1	1	1.006.14.001	Guarnizione ø36	Gasket ø36	Dichtung ø36	Guarnición ø36	Garniture ø36
2	1	1.006.14.004	Guarnizione ø4x1020	Gasket ø4x1020	Dichtung ø4x1020	Guarnición ø4x1020	Garniture ø4x1020
3	1	1.006.14.012	Guarnizione	Gasket	Verzierung	Guarnición	Garniture
4	4	1.015.32.008	Ghiera G1/4"	Ferrule G1/4"	Zwinge G1/4"	Abrazadera G1/4"	Embout G1/4"
5	1	1.015.32.012	Ghiera G3/8 - ø13	Ferrule G3/8 - ø13	Zwinge G3/8 - ø13	Abrazadera G3/8 - ø13	Embout G3/8 - ø13
6	1	1.021.04.006	Manopla	Knob	Griff	Pomo	Poignée
7	1	1.054.04.022	Coperchio	Cover	Deckel	Tapa	Couvercle
8	1	1.078.04.035	Scatola BASIC	Box BASIC	Kasten BASIC	Caja BASIC	Boite BASIC
9	1	1.088.04.036	Cavo elettrico ø4x2.5 L=6000	Power cable ø4x2.5 L=6000	Energie kabel ø4x2.5 L=6000	Cable eléctrico ø4x2.5 L=6000	Cable électrique ø4x2.5 L=6000
10	1	1.110.04.003	Canaletta T1 25x40 G L140	Groove T1 25x40 G L140	Nut T1 25x40 G L140	Surco T1 25x40 G L140	Cannelure T1 25x40 G L140
11	1	1.128.04.003	Morsetto L=68	Clamp L=68	Klemme L=68	Prensita de sujeción L=68	Colier de serrage L=68
12	1	2.008.04.003	Pressostato S2 KH200CI	pressure gauge S2 KH200CI	Druckschalter S2 KH200CI	Presostato S2 KH200CI	Pressostat S2 KH200CI
13	1	2.020.04.038	Cavo	Cable	Kabel	Cable	Cable
14	1	2.020.14.045	Cavo elettrico 2.5 GV L=280	Power cable 2.5 GV L=280	Energie kabel 2.5 GV L=280	Cable eléctrico 2.5 GV L=280	Cable électrique 2.5 GV L=280
15	1	3.013.02.005	Pressostato 3/8	pressure gauge 3/8	Druckschalter 3/8	Presostato 3/8	Pressostat 3/8
16	1	3.024.02.008	Scheda elettronica MCC1	Electronic Board MCC1	ElektronischeKarte MCC1	Tarjeta electrónico MCC1	Carte électronique MCC1
17	1	3.030.02.010	Livellostato KH200CI	Leveller KH200CI	KH200CI	Nivelador KH200CI	Niveleur KH200CI
18	2	4.002.22.001	Vite M4x10 UNI5933	Screw M4x10 UNI5933	Schrauben M4x10 UNI5933	Tornillo M4x10 UNI5933	Vis M4x10 UNI5933
19	1	4.002.44.011	Vite M5x10 UNI5739	Screw M5x10 UNI5739	Schrauben M5x10 UNI5739	Tornillo M5x10 UNI5739	Vis M5x10 UNI5739
20	6	4.002.92.001	Vite autofilettante 3.5x19	Self-tapping Screw 3.5x19	Selbschneidendeschraub e 3.5x19	Tornillo autoblocante 3.5x19	Vis autofiletant 3.5x19
21	2	4.002.92.003	Vite autofilettante 3.5x10 AB	Self-tapping Screw 3.5x10 AB	Selbschneidendeschraub e 3.5x10 AB	Tornillo autoblocante 3.5x10 AB	Vis autofiletant 3.5x10 AB
22	2	4.002.94.005	Vite autofilettante 3.9x13	Self-tapping Screw 3.9x13	Gewindeschneidschraub e 3.9x13	Tornillo Self-tapping 3.9x13	Vies Autofilettante 3.9x13
23	4	4.005.22.009	OR 3024	O-ring 3024	O-ring 3024	OR 3024	Joint torique 3024
24	1	4.005.22.025	OR 3075	O-ring 3075	O-Ring 3075	OR 3075	Joint torique 3075
25	1	4.005.24.001	OR 112	O-ring 112	O-Ring 112	OR 112	Joint torique 112
26	2	4.008.02.001	Rondella 6.4x11x1.6 DIN433 UNI6592 ZEB	Washer 6.4x11x1.6 DIN433 UNI6592 ZEB	Unterlegscheibe 6.4x11x1.6 DIN433 UNI6592 ZEB	Arandela 6.4x11x1.6 DIN433 UNI6592 ZEB	Rondelle 6.4x11x1.6 DIN433 UNI6592 ZEB
27	1	4.008.04.005	Rondella M5 UNI6592	Washer M5 UNI6592	Unterlegsscheibe M5 UNI6592	Arandela M5 UNI6592	Rondelle M5 UNI6592
28	1	4.008.54.002	Rondella di sicurezza UNI8842 M5	Safety washer UNI8842 M5	Sicherheits Scheibe UNI8842 M5	Arandela de seguridad UNI8842 M5	Rondelle de sûreté UNI8842 M5
29	1	4.018.04.013	Interruttore BASIC	Switch BASIC	Schalter BASIC	Interruptor BASIC	Interrupteur BASIC
30	2	4.025.04.008	Seeger KS 6	Seeger KS 6	Seeger KS 6	Seeger KS 6	Seeger KS 6
31	1	4.031.04.003	Termostato 30/150°	Thermostat 30/150°	Thermostat 30/150°	Termostato 30/150°	Thermostat 30/150°
32	1	4.033.04.026	Morsetto 6mm 6P	Clamp 6mm 6P	Klemme 6mm 6P	Prensita de sujeción 6mm 6P	Colier de serrage 6mm 6P
33	1	4.033.04.034	Morsettiera 6mmq 11p	Terminal Block 6mmq 11p	Klemmleisten 6mmq 11p	Tableros de bornes 6mmq 11p	Plaques à bornes 6mmq 11p
34	1	4.035.02.017	Condensatore 8mf 450V	Condenser 8mf 450V	Kondensator 8mf 450V	Condensador 8mf 450V	Condenseur 8mf 450V
35	1	4.040.04.001	Bobina	Solenoid	Bandspule	Bobina	Bobine

Motopompa 400V 50Hz HC506

Motorpump 400V 50Hz HC506

Motopompe 400V 50Hz HC506

Motorpumpe 400V 50Hz HC506

Motobomba 400V 50Hz HC506

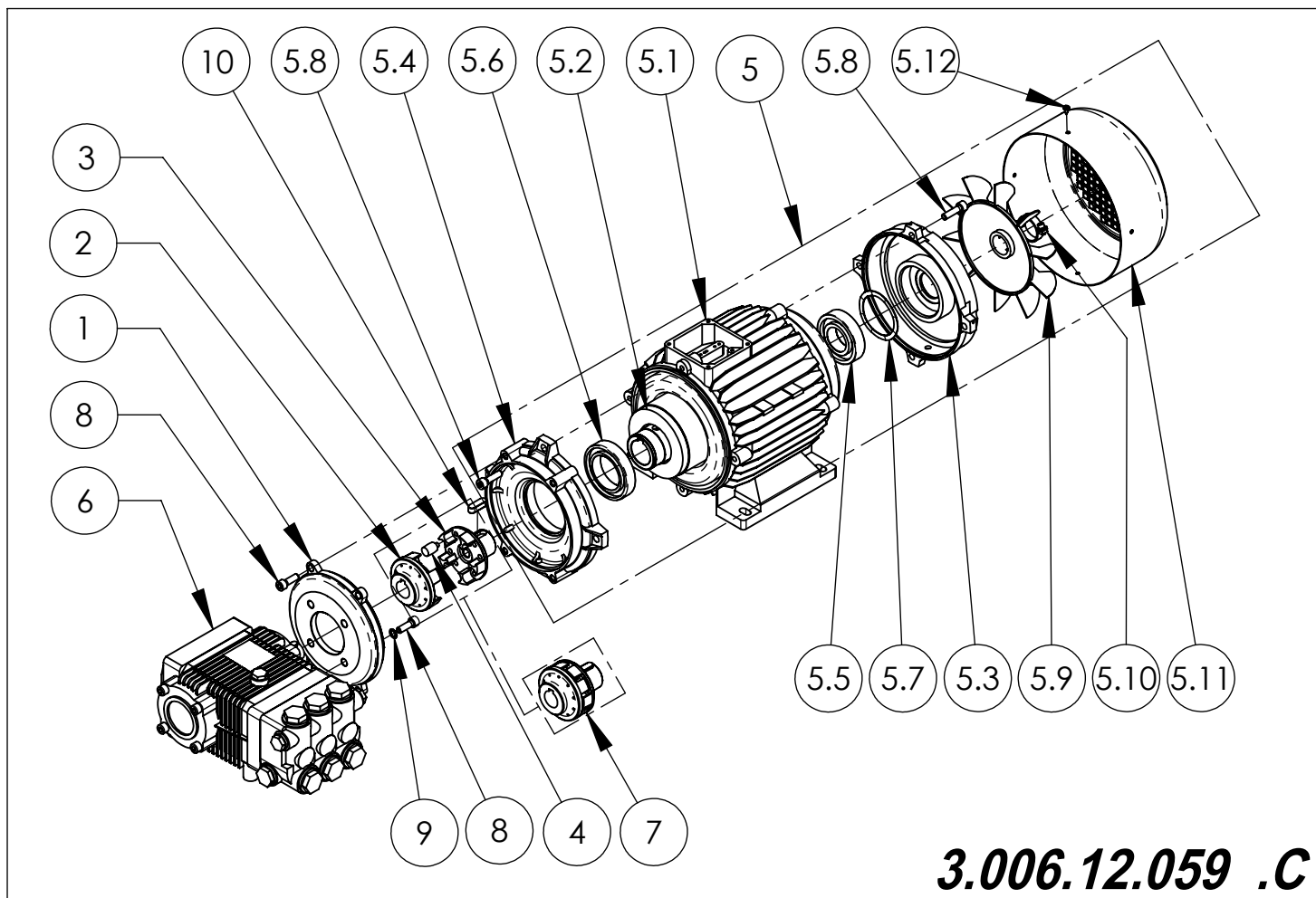

Pos.	Q.tà	Cod.	ITALIANO	ENGLISH	DEUTSCH	ESPAÑOL	FRANCAIS
1	1	1.074.02.034	Flangia M112	Flange M112	Flansch M112	Borde M112	Bride M112
2	1	1.131.02.005	Mozzo G112 (ø24)	Hub G112 (ø24)	Nabe G112 (ø24)	Cubo G112 (ø24)	Moyeu G112 (ø24)
3	1	1.131.02.006	Mozzo G112 (ø35)	Hub G112 (ø35)	Nabe G112 (ø35)	Cubo G112 (ø35)	Moyeu G112 (ø35)
4	10	1.157.02.001	Ammortizzatore	Cushion	Dämpfer	Amortiguador	Amortisseur
5	1	3.002.12.033	Motore Elettrico M112 400V 50Hz 3F	Electric Motor M112 400V 50Hz 3F	Elektromotor M112 400V 50Hz 3F	Motor Eléctrico M112 400V 50Hz 3F	Moteur électrique M112 400V 50Hz 3F
5.1	1	2.017.02.023	Carter Montato M112 50Hz 3F (G)	Assembled Guard M112 50Hz 3F (G)	Montiertes Gehäuse M112 50Hz 3F (G)	Ensamblado Cáter M112 50Hz 3F (G)	Carter assemblé M112 50Hz 3F (G)
5.2	1	2.014.02.046	Rotore MEC112	Rotor MEC112	Rotor MEC112	Rotor MEC112	Rotor MEC112
5.3	1	1.074.02.007	Flangia Mec112 P	Flange Mec112 P	Flansch Mec112 P	Borde Mec112 P	Bride Mec112 P
5.4	1	1.074.02.035	Flangia M112 A-G	Flange M112 A-G	Flansch M112 A-G	Borde M112 A-G	Bride M112 A-G
5.5	1	4.016.02.006	SKF 6207-2Z C3 35x72x17	Bearing 35x72x17	Kugellager 35x72x17	Rodamiento 35x72x17	Roulement 35x72x17
5.6	1	4.016.02.011	SKF 6010 ZZ C3 (50x80x16)	Bearing 50x80x16	Kugellager 50x80x16	Rodamiento 50x80x16	Roulement 50x80x16
5.7	1	4.049.12.003	Anello UNI6207 58x71.8x0.6	Ring UNI6207 58x71.8x0.6	Ring UNI6207 58x71.8x0.6	Anillo UNI6207 58x71.8x0.6	Bague UNI6207 58x71.8x0.6
5.8	8	4.002.12.004	Vite M8x30 UNI5931	Screw M8x30 UNI5931	Schrauben M8x30 UNI5931	Tornillo M8x30 UNI5931	Vis M8x30 UNI5931
5.9	1	1.073.02.003	Ventola M112	Impeller M112	Antereiber M112	Impledor M112	Roue à aubes M112
5.10	1	1.045.02.006	Fascetta Ventola FA100	Clamp Impeller FA100	Klemme Antereiber FA100	Faja Impledor FA100	Petit bande Roue à aubes FA100
5.11	1	1.046.02.012	Protezione M112	Protection M112	Scuhtz M112	Protección M112	Protection M112
5.12	4	4.002.94.015	Vite autofilettante 3.9x9.5	Self-tapping Screw 3.9x9.5	Selbschneidendeschraube 3.9x9.5	Tornillo autoblocante 3.9x9.5	Vis autofiletant 3.9x9.5
6	1	3.015.12.043	Pompa HC506I MR	Pump HC506I MR	Pump HC506I MR	Bomba HC506I MR	Pompe HC506I MR
7	1	3.055.02.002	Giunto ø24-ø35	Coupling ø24-ø35	Kupplung ø24-ø35	Acoplamiento ø24-ø35	Accouplement ø24-ø35
8	8	4.002.11.002	Vite M8x25 UNI5931	Screw M8x25 UNI5931	Schrauben M8x25 UNI5931	Tornillo M8x25 UNI5931	Vis M8x25 UNI5931
9	4	4.008.52.002	Rondella di sicurezza UNI8842 M8	Safety washer UNI8842 M8	Sicherheits Scheibe UNI8842 M8	Arandela de seguridad UNI8842 M8	Rondelle de sûreté UNI8842 M8
10	1	4.021.02.005	Chiavetta 10x8x30 UNI6604-A	Key 10x8x30 UNI6604-A	Keil 10x8x30 UNI6604-A	Chaveta 10x8x30 UNI6604-A	Clavette 10x8x30 UNI6604-A



KRÜGER TECHNOLOGY S.L.
B-82526583
Polígono Agustinos C/G Parcela B2
31013 Pamplona (Navarra) - ESPAÑA
+34 948 343 393 - info@kruger.es - www.kruger.es