

Pos.	Cod.	Descrizione	Description	Descripción	N°
01	1.001.04.031	Raccordo	Connection	Racor	1
02	1.001.14.012	Raccordo	Connection	Racor	1
03	1.001.24.013	Raccordo "T"	"T" connection	Racor "T"	1
04	1.003.04.008	Rondella VBR	VBR washer	Arandela VBR	2
05a	1.006.12.003	Guarnizione copribasetta WSF4000	Gasket WSF4000	Empaquetadura WSF4000	1
05b	1.006.12.009	Guarnizione copribasetta SF5000	Gasket SF5000	Empaquetadura SF5000	1
06	1.011.04.047	Supporto antivibrante	Anti-vibration support	Soporte antivibracion	4
07	1.012.02.005	Tappo VBR	VBR plug	Tapa VBR	1
08	1.012.14.003	Tappo 3/8"G	3/8"G plug	Tapa 3/8"G	2
09	1.012.14.004	Tappo 1/2"G	1/2"G plug	Tapa 1/2"G	2
10	1.012.14.010	Tappo 1/2"GM - 1/4"GF	1/2"GM - 1/4"GF plug	Tapa 1/2"GM - 1/4"GF	1
11	1.015.02.019	Ghiera VBR	VBR ring nut	Abrazadera VBR	1
12	1.015.04.004	Ghiera PG16	PG16 ring nut	Abrazadera PG16	1
13	1.015.04.009	Ghiera	Ring nut	Abrazadera	1
14	1.015.24.002	Ghiera	Ring nut	Abrazadera	1
15	1.021.02.012	Manopola VBR	VBR hand grip	Pomo VBR	1
16	1.025.12.010	Molla pressostato	Pressure gauge spring	Muelle presostato	1
17	1.025.22.001	Molla blu	Blue spring	Muelle azul	1
18	1.036.02.001	Inserto VBR	VBR insert	Lagajo VBR	1
19	1.079.04.005	Copribasetta SF5000			1
20	1.081.02.001	Forcella pressostato	Pressure gauge fork	Horquilla presostato	1

Pos.	Cod.	Descrizione	<i>Description</i>	Descripción	N°
21	1.001.14.024	Raccordo	Connection	Racor	1
22	1.006.11.007	Rondella in nylon	Nylon washer	Arandela de nylon	1
23	4.005.22.026	OR 3081	O-Ring 3081	OR 3081	1
24	4.036.04.005	Tappo VAM	VAM plug	Tapa VAM	1
25	2.021.02.001	Premontato innesto sfera	Preassembled ball coupling	Preensamblado acoplamiento	1
26					
27					
28	1.089.04.003	Staffa manometro	Pressure gauge bracket	Brida manometro	1
29	1.096.04.001	Niples 3/8"G	3/8"G nipples	Niples 3/8"G	1
30	1.096.04.006	Niples 1/2"G	1/2"G nipples	Niples 1/2"G	1
31					
32	1.125.04.002	Copertura	Cover	Bastidor	1
33	2.006.24.052	Tubo manometro	Pressure gauge tube	Tubo manometro	1
34	2.006.24.038	Tubo	By-pass tube	Tubo by-pass	1
35	2.006.24.029	Tubo mandata caldaia	Boiler Intake tube	Tubo caldera	1
36	2.006.24.030	Tubo accumulatore	Accumulator tube	Tubo accumulador	1
37	2.006.24.031	Tubo uscita caldaia	Boiler outake tube	Tubo caldera	1
38	2.006.24.032	Tubo alta pressione pompa	High pressure pump tube	Tubo alta pression bomba	1
39	2.006.24.009	Tubo by-pass	By-pass tube	Tubo by-pass	1
40	2.013.04.015	Tappo 1/4"G	1/4"G plug	Tapa 1/4"G	1
41a	2.018.02.001	Morsettiera WSF4000	Junction box WSF4000	Terminal de connexion WSF4000	1
41b	2.018.02.002	Morsettiera SF5000	Junction box SF5000	Terminal de connexion SF5000	1
42	2.022.04.008	Basamento	Basement	Basamiento	1
43a	2.031.04.089	Quadro elettrico WSF4000	Switchboard WSF4000	Panel mandos WSF4000	1
43b	2.031.04.085	Quadro elettrico SF5000	Switchboard SF5000	Panel mandos SF5000	1
44	2.037.04.005	Serbatoi acqua	Water tank	Tanque agua	1
45	2.048.04.008	Collettore	Manifold	Colector	1
46	2.100.04.002	Gruppo valvole	Valves group	Gruppo valvula	1
47					
48a	3.006.12.059	Motopompa WSF4000	Motopump WSF4000	Motobomba WSF4000	1
48b	3.006.12.054	Motopompa SF5000	Motopump SF5000	Motobomba SF5000	1
49	3.022.12.034	Pistola	Trigger gun	Pistola	1
50	3.021.22.003	Lancia	Lance	Lanza	1
51a	3.026.24.025	Caldaia WSF4000	Boiler WSF4000	Caldera WSF4000	1
51b	3.026.04.024	Caldaia SF5000	Boiler SF5000	Caldera SF5000	1
52	3.032.02.004	Filtro acqua	Water filter	Filtro agua	1
53	3.040.04.002	Accumulatore	Accumulator	Accumulador	1
54	4.002.12.011	Vite M6x18	M6x18 screw	Tornillo M6x18	4
55	4.002.14.005	Vite M8x20	M8x20 screw	Tornillo M8x20	2
56	4.002.14.012	Vite M6x10	M6x10 screw	Tornillo M6x10	4
57	4.002.14.014	Vite M8x16	M8x16 screw	Tornillo M8x16	4
58	4.002.14.037	Vite M6x12	M6x12 screw	Tornillo M6x12	7
59	4.002.44.017	Vite M8x75	M8x75 screw	Tornillo M8x75	2
60	4.002.44.018	Vite M10x35	M10x35 screw	Tornillo m10x35	4
61	4.002.92.009	Vite M5x14	M5x14 screw	Tornillo M5x14	2
62	4.002.94.021	Vite M5x8	M5x8 screw	Tornillo M5x8	1
63					
64	4.004.32.002	Grano	Grub screw	Grano	2
65	4.005.22.003	Rondella pressostato	Pressure gauge washer	Arandela presostato	1
66	4.008.02.001	Rondella	Washer	Arandela	4
67	4.008.02.002	Rondella di rame	Copper washjer	Arandela	1
68	4.008.04.002	Rondella	Washer	Arandela	7
69	4.008.04.004	Rondella	Washer	Arandela	4
70	4.008.14.004	Rondella di rame	Copper washer	Arandela	1
71	4.008.12.002	Rondella di rame	Copper washer	Arandela	1
72	4.008.54.002	Rondella SCHNORR	SCHNORR washer	Arandela SCHNORR	1
73	4.008.54.003	Rondella elastica	Elastic washer	Arandela elastico	4
74	4.009.12.001	Dado	Nut	Tuerca	1
75	4.020.14.002	Manometro	Pressure gauge	Manometro	1
76					
77	4.026.02.002	Pressacavo skintop	Skintop		
78a	4.027.02.007	Ugello WSF4000	Nozzle WSF4000	ToberaWSF4000	1

Pos.	Cod.	Descrizione	<i>Description</i>	Descripción	N°
78b	4.027.02.051	Ugello SF5000	Nozzle SF5000	Tobera SF5000	1
79					
80					
81					
82					
83					
84	4.047.04.005	Inserto M8	M8 insert	Inserto M8	3
85	4.047.04.007	Inserto M10	M10 insert	Inserto M10	4
86	4.070.04.001	Rondella 3/8"G	3/8"G washer	Arandela 3/8"G	4
87	4.070.04.002	Rondella 1/2"G	1/2"G washer	Arandela 1/2"G	5

PROLUNGA – EXTENSION – ALARGADOR

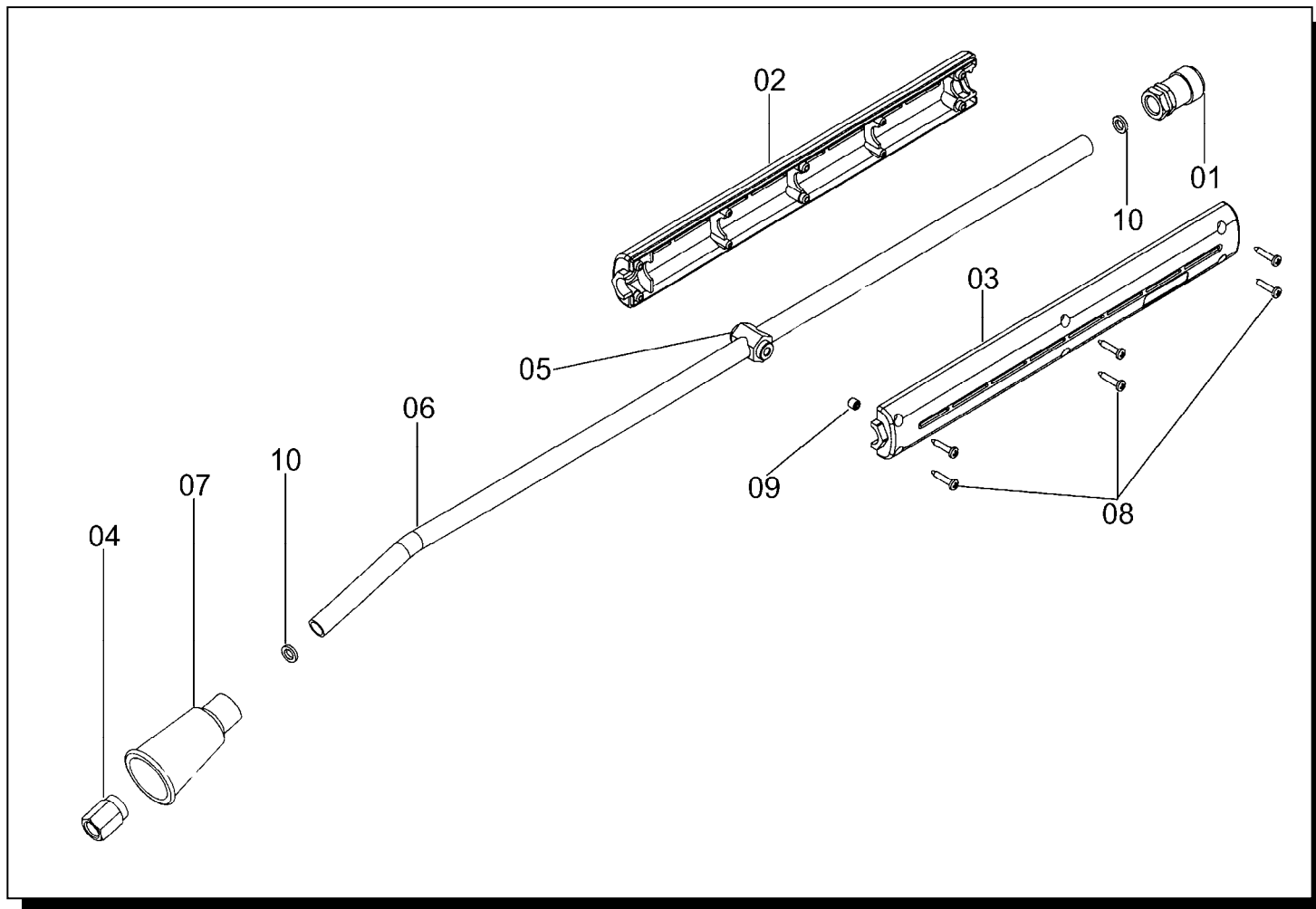

Pos.	Cod.	Descrizione	Description	Descripción	N°
01	1.001.02.046	Raccordo ARF 1/4" G	1/4" G ARF union	Racor ARF 1/4" G	1
02	1.017.02.003	Impugnatura superiore	Upper grip	Empunadura superior	1
03	1.017.02.004	Impugnatura inferiore	Lower grip	Empunadura inferior	1
04	1.019.02.010	Riduzione porta ugello	Nozzleholder reduction gear	Reduccion portatobera	1
05	1.036.02.006	Inserto lancia SC10	Lance insert	Inserto lanza	1
06	1.044.32.005	Tubo inox 13x1,5x700 1/4" G	Inox tube 13x1,5x700 1/4" G	Tubo inox 13x1,5x700 1/4" G	1
07	1.046.02.005	Protezione ugello	Nozze protection	Proteccion tobera	1
08	4.002.92.001	Vite Autofilettante 3,5x19	Self-tapping screw 3,5x19	Tornillo autoblocante 3,5x19	6
09	4.004.12.001	Vite STEI M6x6 UNI5923-67	STEI M6x6 UNI5923-67 screw	Tornillo STEI M6x6 UNI5923-67	1
10	4.008.12.003	Rondella rame 1/4" G	1/4" G copper washer	Arandola 1/4" G	2

PREMONTATO CALDAIA – PREASSEMBLED BOILER – PREENSAMBLADO CALDERA

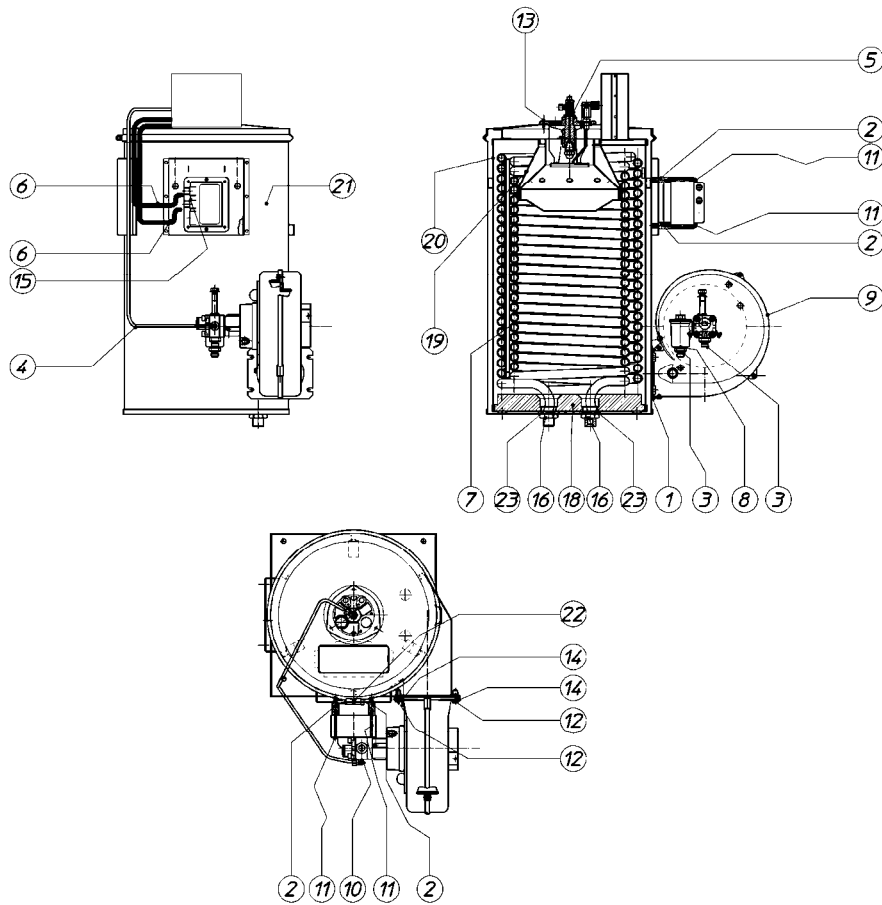

Pos.	Cod.	Descrizione	Description	Descripción	N°
01	1.006.04.001	Guarnizione	Gasket	Empaquetadura	1
02	1.011.04.013	Supporto trasformatore	Transformer support	Soporte transformador	2
03	1.019.04.014	Nipples	Nipples	Nipples	2
04	1.044.54.012	Tubo rame gasolio	Gas oil copper tube	Tubo gasoleo	1
05a	2.012.04.020	Premontato elettrodi WSF4000	Preassembled electrodes WSF4000	Preensamblado electrodos WSF4000	1
05b	2.012.04.019	Premontato elettrodi SF5000	Preassembled electrodes SF5000	Preensamblado electrodos SF5000	1
06	2.020.04.012	Cavo trasformatore	Transformer wire	Cable transformador	2
07	2.029.04.008	Serpentina	Warming	Serpent	1
08	3.032.04.009	Filtro gasolio	Gas-oil filter	Filtro gasoleo	1
09	3.038.02.015	Convogliatore	Conveyor	Transportador	1
10	3.050.14.001	Raccordo tubo gasolio	Gas oil tube connection	Racor tubo gasoleo	1
11	4.002.14.009	Vite M4x50	M4x50 screw	Tornillo M4x50	2
12	4.002.44.001	Vite M6x20	M6x20 screw	Tornillo M6x20	2
13	4.002.94.017	Vite autofilettante 3,9x13	3,9x13 self-tapping screw	Tornillo autobloccante 3,9x13	3
14	4.008.24.001	Rondella	Washer	Arandela	2
15	4.030.04.001	Trasformatore	Transformer	Transformador	1
16	1.015.24.002	Ghiera	Ring nut	Abrazadera	2
17	1.054.04.006	Coperchio	Cover	Tapa	1
18	1.094.04.005	Isolante	Insulator	Aislante	1
19	2.012.04.013	Camino	Chimney	Chimenea	1
20	2.023.04.010	Camicia interna	Internal jacket	Camisa interior	1
21	2.023.04.021	Camicia esterna	External jacket	Camisa esterna	1
22	2.056.04.001	Fascetta	Clamp	Faja	1
23	1.060.04.018	Distanziale 6mm	6mm spacer	Distanciador 6mm	2

PREMONTATO CONVOGLIATORE – PREASSEMBLED CONVEYOR – PREESAMBLADO TRANSPORTADOR

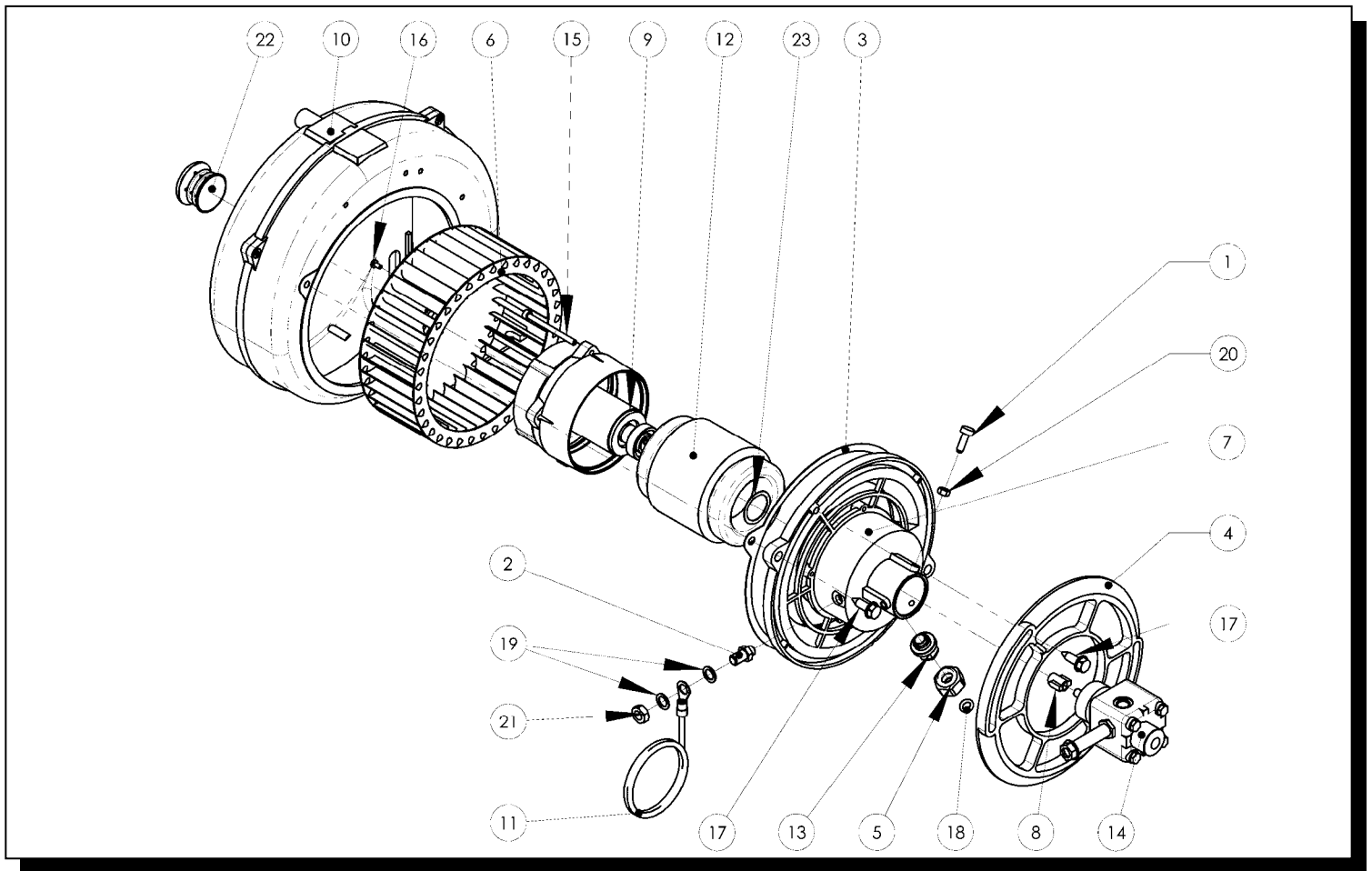

Pos.	Cod.	Descrizione	Description	Descripción	N°
01	1.004.04.001	Vite M5x20	M5x20 screw	Tornillo M5x20	3
02	1.004.22.002	Vite messa a terra	Ground screw	Tornillo de tierra	1
03	1.006.22.002	Guarnizione	Gasket	Empaquetadura	1
04	1.009.02.004	Griglia controllo aria	Air check grate	Rejilla de control aire	1
05	1.015.32.008	Ghiera	Ring nut	Abrazadera	1
06	1.073.02.006	Ventola	Fan	Ventilador	1
07	1.074.02.025	Flangia	Flange	Brida	1
08	1.098.02.001	Giunto	Coupling	Junta	1
09	2.014.02.030	Albero + rotore	Shaft + rotor	Eje + rotor	1
10	2.017.22.001	Carter convogliatore	Conveyor guard	Cartér transportador	1
11	2.020.14.088	Cavo di terra	Ground wire	Cable de tierra	1
12	2.025.22.001	Statore	Stator	Estátor	1
13	2.027.02.004	Pressacavo	Cable clamping	Prensacables	1
14	3.015.24.007	Pompa gasolio	Gas oil pump	Bomba gasoleo	1
15	4.002.12.016	Vite M4x45	M4x45 screw	Tornillo M4x45	4
16	4.002.72.004	Vite M3x6	M3x6 screw	Tornillo M3x6	4
17	4.002.92.007	Vite autofilettante 6,3x16	6,3x16 self-tapping screw	Tornillo autobloccante 6,3x16	2
18	4.005.22.009	OR	O-Ring	OR	1
19	4.008.52.002	Rondella	Washer	Arandela	1
20	4.009.02.001	Dado M5	M5 nut	Tuerca M5	3
21	4.009.04.003	Dado M8	M8 nut	Tuerca M8	1
22	4.036.02.002	Tappo	Plug	Tapa	1
23	4.049.12.005	Anello di compensazione			1

COPERCHIO PORTA ELETTRODI – *ELECTRODES HOLDER* – TAPA PORTAELECTRODOS

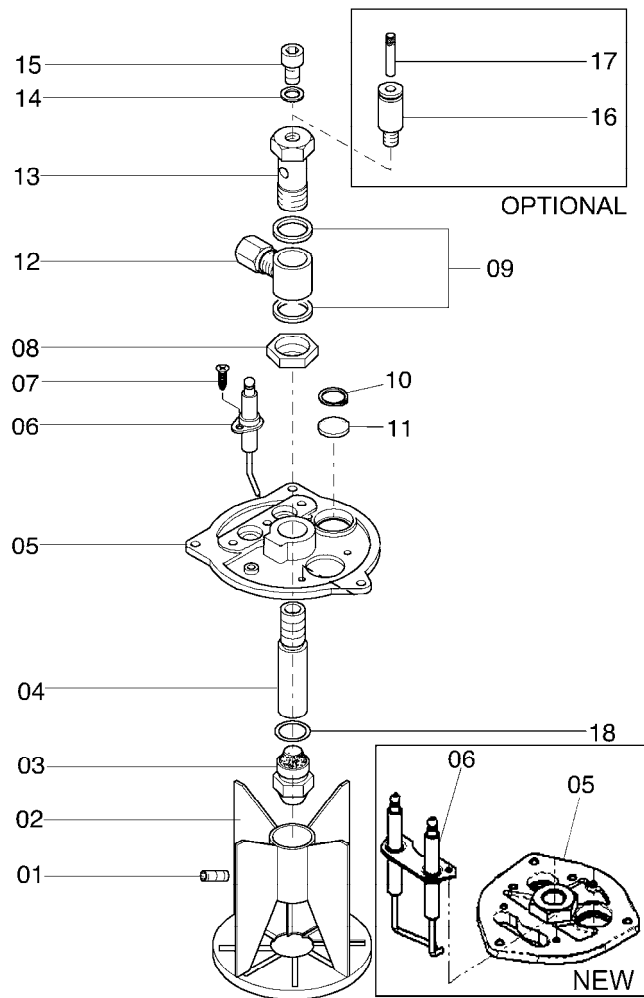

Pos.	Cod.	Descrizione	Description	Descripción	N°
01	4.004.34.001	Grano	Grub nut	Grano	1
02	2.009.04.002	Deflettore	Deflector	Deflector	1
03°	4.027.14.015	Ugello WSF4000	Nozzle WSF4000	Tobera WSF4000	1
03b	4.027.14.011	Ugello SF5000	Nozzle SF5000	Tobera SF5000	1
04	1.001.04.006	Raccordo porta ugello	Nozzle holder	Racor porta tobera	1
05a	1.074.04.003	Flangia elettrodo singolo	Single electrode flange	Brida electrodo singolo	1
05b	1.074.04.011	Flangia doppio elettrodo	Double electrodes flange	Brida dos electrodos	1
06a	2.032.04.003	Elettrodo	Electrode	Electrodo	2
06b	2.032.04.004	Doppio elettrodo	Double electrodes	Electrodos doppio	1
07	4.002.94.005	Vite autofilettante M3,9x13	M3,9x13 self-tapping screw	Tornillo autobloccante M3,9x13	2
08	1.015.24.003	Ghiera	Ring nut	Abrazadera	1
09	4.008.12.005	Rondella rame	Copper washer	Arandela	2
10	4.025.04.002	Seeger	Seeger	Seeger	1
11	1.102.04.001	Vetrino	Glass	Vidrio	1
12	3.050.34.001	Raccordo	Connection	Racor	1
13	1.012.14.012	Tappo	Plug	Tapa	1
14	4.008.14.003	Rondella rame	Copper washer	Arandela	2
15	4.002.14.022	Vite M5x10	M5x10 screw	Tornillo M5x10	1
16	4.012.04.006	Raccordo controllo pressione	Pressure control union	Conector rápido	1
17	4.036.04.007	Tappo	Plug	Tapa	1
18	4.005.14.004	OR	O-Ring	OR	1

PREMONTATO SERBATOIO ACQUA – PREASSEMBLED WATER TANK – PREENSAMBLADO TANQUE AGUA

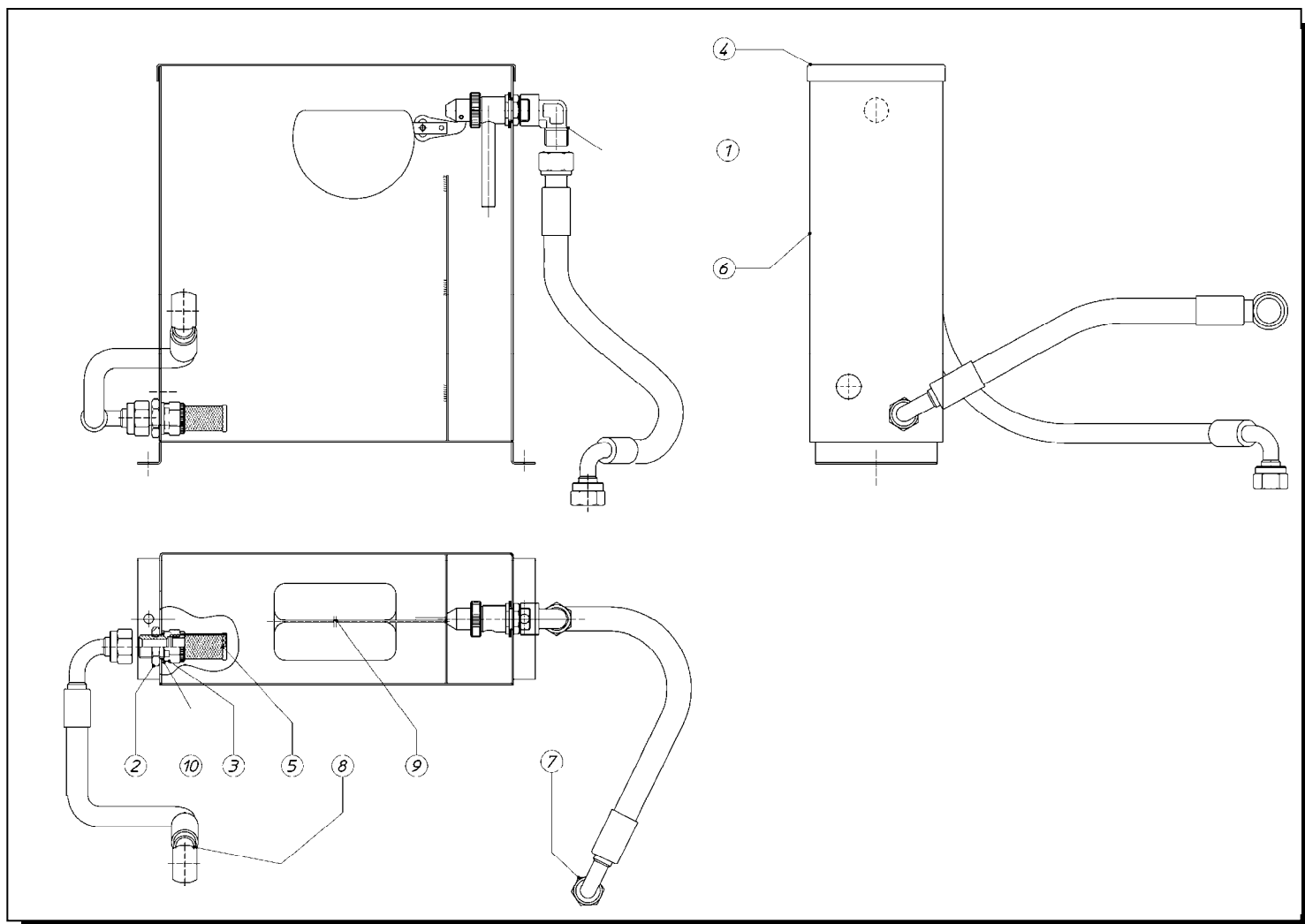

Pos.	Cod.	Descrizione	Description	Descripción	N°
01	1.001.14.011	Raccordo	Connection	Racor	1
02	1.015.24.002	Ghiera	Ring nut	Abrazadera	1
03	1.019.04.013	Riduzione	Reduction	Ridución	1
04	1.054.04.036	Coperchio	Cover	Tapon	1
05	2.011.02.004	Filtro	Filter	Filtro	1
06	2.037.04.003	Serbatoio	Tank	Tanque	1
07	2.074.04.005	Tubo entrata	Intake tube	Tubo entrada	1
08	2.074.04.008	Tubo uscita	Outtake tube	Tubo uscita	1
09	3.027.04.002	Galleggiante	Float	Flottador	1
10	4.070.04.002	Rondella 1/2"G	1/2"G washer	Arandola 1/2"G	1

**PREMONTATO GRUPPO VALVOLA – PREEASSEMBLED VALVE
GROUP – PREENSAMBLADO GRUPOS VÁLVULA**

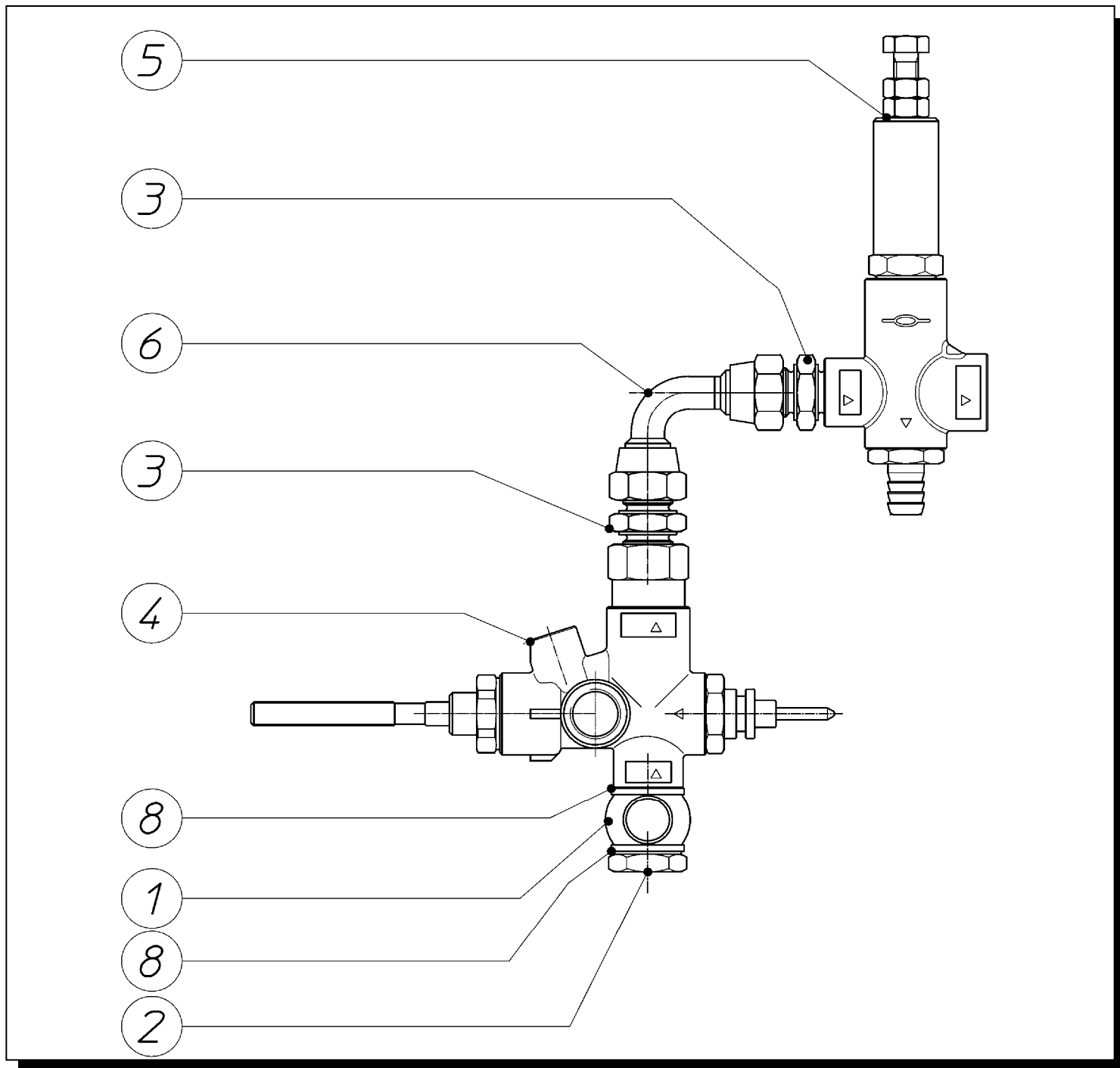

Pos.	Cod.	Descrizione	Description	Descripción	N°
01	1.001.34.005	Occhiello	Eyelet	Argolla	1
02	1.012.14.003	Tappo	Plug	Tapa	1
03	1.096.04.001	Nipples	Nipples	Nipples	2
04	2.00.34.005	Valvola VBR	VBR valve	Válvula VBR	1
05	3.003.22.002	Valvola di sicurezza	Safety valve	Válvula de seguridad	1
06	4.012.04.009	Raccordo	Connection	Racor	1
07					
08	4.070.04.001	Rondella	Washer	Arandela	2

VALVOLA SICUREZZA – SAFETY VALVE – VÁLVULA DE SEGURIDAD

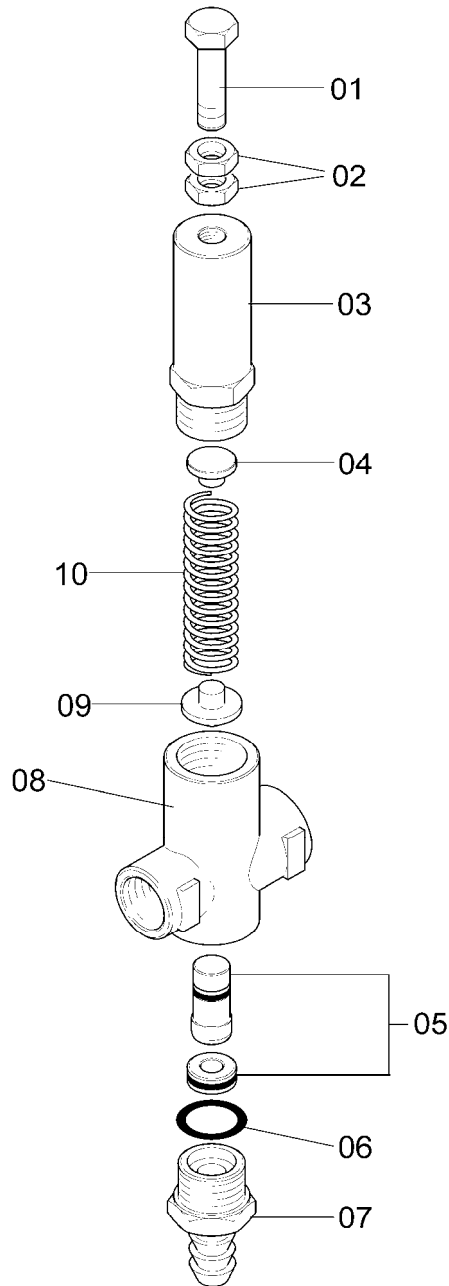

Pos.	Cod.	Descrizione	Description	Descripción	N°
01	4.002.42.003	Vite M8x30	M8x30 screw	Tornillo M8x30	1
02	4.009.04.003	Dado M8	M8 nut	Tuerca M8	2
03	1.021.02.011	Manopola	Grip	Pomo	1
04	1.072.02.011	Premimolla superiore	Upper spring press device	Sujeta-resorte superior	1
05	9.005.02.004	Kit ricambio otturatore	Shutter spare kit	Kit repuestos obturador	1
06	4.005.21.011	Guarnizione	Gasket	Empaquetadura	1
07	1.049.02.007	Portagomma	Tube holder	Portagoma	1
08	1.020.22.014	Corpo valvola di sicurezza	Safety valve body	Cuerpo válvula de seguridad	1
09	1.072.02.012	Premimolla inferiore	Lower spring press device	Sujeta-resorte inferior	1
10	1.025.22.007	Molla valvola di sicurezza	Safety valve spring	Muelle válvula de seguridad	1

VALVOLA BY-PASS – BY-PASS VALVE – VÁLVULA BY-PASS

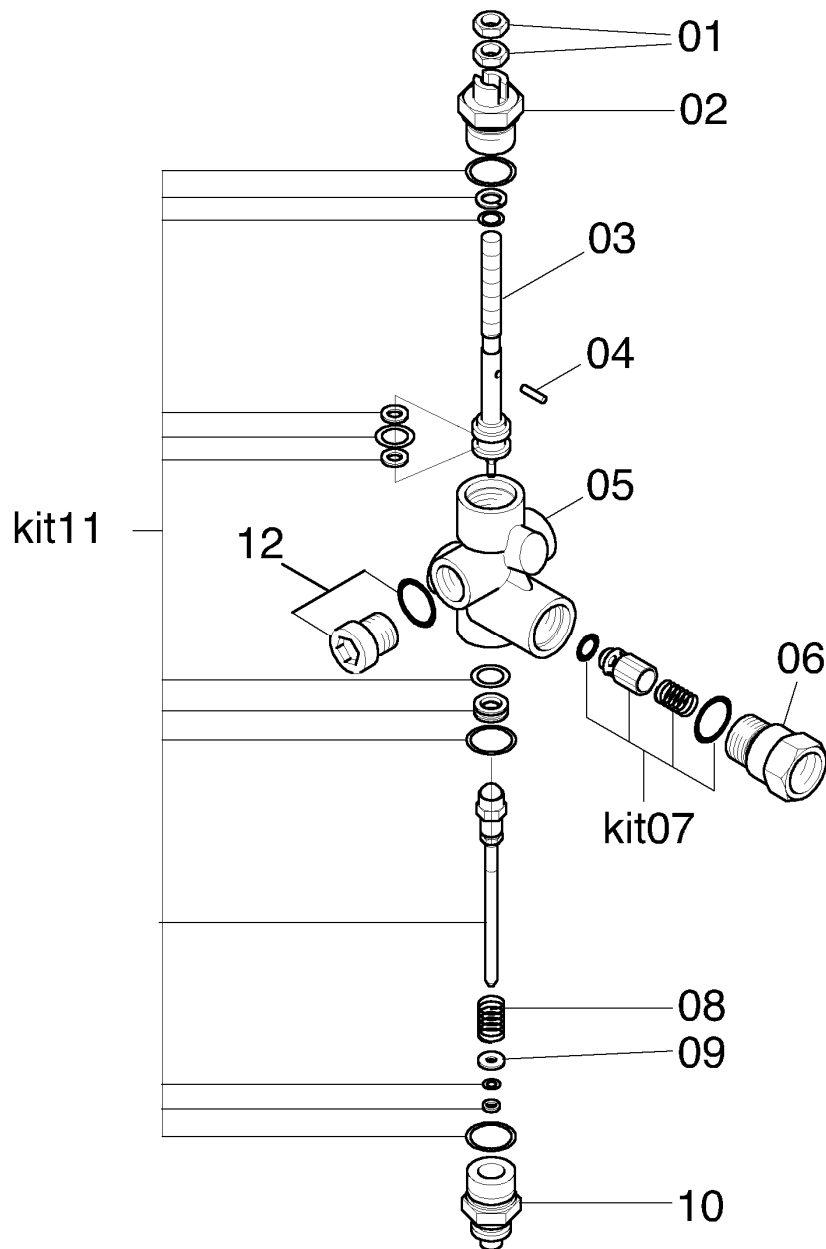

Pos.	Cod.	Descrizione	Description	Descripción	N°
01	1.035.02.001	Dado massima pressione	Max pressure nut	Tuerca maxima presión	2
02	1.001.02.002	Raccordo guida stelo	Stem guide connection	Racor guía de vastago	1
03	1.037.02.001	Stelo VRB	VRB stem	Vastago VRB	1
04	4.011.12.001	Spina elastica	Elastic pin	Espina elástico	1
05	1.020.22.020	Corpo VRB	VRB body	Cuerpo VRB	1
06	1.001.02.003	Raccordo mandata	Delivery connection	Conexión envío	1
07	9.005.02.001	Otturatore mandata	Outlet shutter	Obturador	1
08	1.025.12.002	Molla	Spring	Muelle	1
09	1.003.02.004	Rondella	Washer	Arandela	1
10	1.001.02.024	Raccordo pressostato	Pressure gauge connection	Racor presostato	1
11	9.003.02.007	Kit tenuta Totalstop	Totalstop spare seals kit	Kit cerres Totalstop	
12	2.013.04.016	Tappo	Plug	Tapa	1

PREMONTATO QUADRO ELETTRICO – PREEASSEMBLED SWITCHBOARD – PREENSAMBLADO PANEL MANDOS

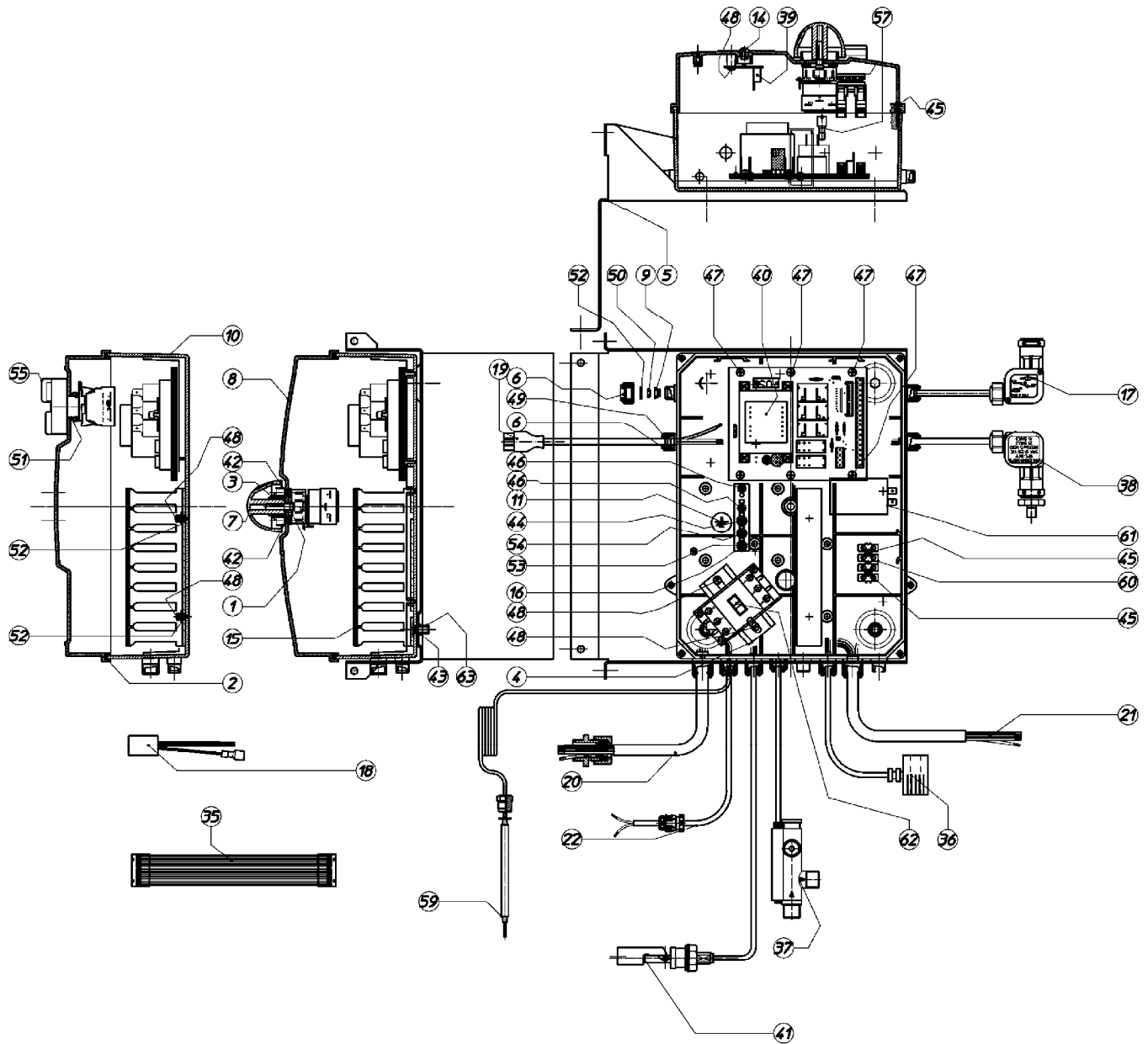

Pos.	Cod.	Descrizione	Description	Descripción	N°
01	1.006.14.001	Guarnizione manopola	Hand grip gasket	Empaquetadura pomo	1
02	1.006.14.004	Guarnizione	Gasket	Empaquetadura	1
03	1.006.14.012	Guarnizione interruttore rotativo	Revolving switch gasket	Empaquetadura interruttore rotante	1
04	1.011.04.033	Supporto con barra SF5000	Support with rod SF5000	Soporte con barra SF5000	1
05	1.011.04.044	Supporto quadro elettrico	Switchboard support	Soporte panel mandos	1
06	1.015.32.008	Ghiera	Ring nut	Abrazadera	2
07	1.021.04.006	Manopola	Hand grip	Pomo	1
08	1.054.04.002	Coperchio	Cover	Tapon	1
09	1.064.04.010	Boccola			1
10	1.078.04.017	Scatola elettrica	Electric box	Caja electrica	1
11					

PREMONTATO QUADRO ELETTRICO – PREEASSEMBLED SWITCHBOARD – PREENSAMBLADO PANEL MANDOS

Pos.	Cod.	Descrizione	Description	Descripción	N°
12					
13					
14	1.002.04.002	Vetro spia	Spy glass	Vidrio spia	1
15	1.110.04.001	Canala cablata	Wired raceway	Canal cableado	1
16	1.128.04.003	Barra messa a terra	Ground bar	Barra de tierra	1
17	2.008.04.001	Pressostato S2	S2 pressure gauge	Presostato S2	1
18	2.011.04.002	Filtro capacitivo	Antinoise filter	Supresor de interferencias	1
19	2.020.04.003	Cavo trasformatore	Transformer wire	Cable transformador	1
20b	2.020.04.041	Cavo elettrico WSF4000	Electric wire WSF4000	Cable eléctrico WSF4000	1
20a	2.020.04.055	Cavo elettrico SF5000	Electric wire SF5000	Cable eléctrico SF5000	1
21a	2.020.04.043	Cavo alimentazione WSF4000	Power wire WSF4000	Cable alimentacion WSF4000	1
21b	2.020.04.056	Cavo alimentazione SF5000	Power wire SF5000	Cable alimentacion SF5000	1
22a	2.020.04.044	Cavo termico WSF4000	Termic wire WSF4000	Cable termico WSF4000	1
21b	2.020.04.057	Cavo termico SF5000	Termic wire SF5000	Cable termico SF5000	1
23					
24					
25					
26					
27					
28					
29					
30					
31					
32					
33					
34					
35	2.020.32.001	Cavo piatto	Multiwire	Connexión electrica multipla	1
36	2.083.04.001	Bobina gasolio	Gas-oil spool	Bobina gasoleo	1
37	2.086.04.002	Flussostato	Flow switch	Flusostato	1
38	3.013.04.002	Pressostato S3	S3 pressure gauge	Presostato S3	1
39	3.024.02.019	Sceda LED	LED card	Ficha LED	1
40	3.024.02.020	Scheda MCC10	MCC10 card	Ficha MCC10	1
41	3.030.02.007	Livellostato	Leveller	Nivelador	1
42	4.002.22.001	Vite M4x10	M4x10 screw	Tornillo M4x10	2
43	4.002.24.003	Vite M6x16	M6x16 screw	Tornillo M6x16	4
44	4.02.44.011	Vite M5x10	M5x10 screw	Tornillo M5x10	3
45	4.002.92.001	Vite autofilettante 3,5x19	3,5x19 self-tapping screw	Tornillo autobloccante 3,5x19	6
46	4.002.92.003	Vite autofilettante 3,5x10	3,5x10 self-tapping screw	Tornillo autobloccante 3,5x10	2
47	4.002.94.005	Vite autofilettante 3,9x13	3,9x13 self-tapping screw	Tornillo autobloccante 3,9x13	8
48	4.002.94.015	Vite autofilettante 3,9x9,5	3,9x9,5 self-tapping screw	Tornillo autobloccante 3,9x9,5	6
49	4.005.22.009	OR 3024	O-Ring 3024	OR 3024	1
50	4.005.22.012	OR 2-105	O-ring 2-105	OR 2-105	1
51	4.005.22.025	OR 3075	O-Ring 3075	OR 3075	1
52	4.008.02.001	Rondella	Washer	Arandela	3
53	4.008.04.005	Rondella	Washer	Arandela	3
54	4.008.54.002	Rondella SCHNORR	SCHNORR washer	Arandela SCHNORR	3
55	4.018.04.008	Interruttore doppio pulsante	Double control switch	Interruptor dos mandos	1
56					
57					
58					
59	4.031.04.003	Termostato	Thermostat	Termostato	1
60	4.033.04.002	Morsettiera	Junction box	Terminal de connexion	1
61	4.035.04.002	Condensatore	Condenser	Condensador	1
62	4.042.04.008	Teleruttore SF5000	Magnetic switch SF5000	Teleruptor SF5000	1
63	4.047.04.012	Inserto	Insert	Inserto	4

COMPRESSIVO MOTOPOMPA – MOTORPUMP LAYOUT – ESQUEMA GENERAL MOTOBOMBA

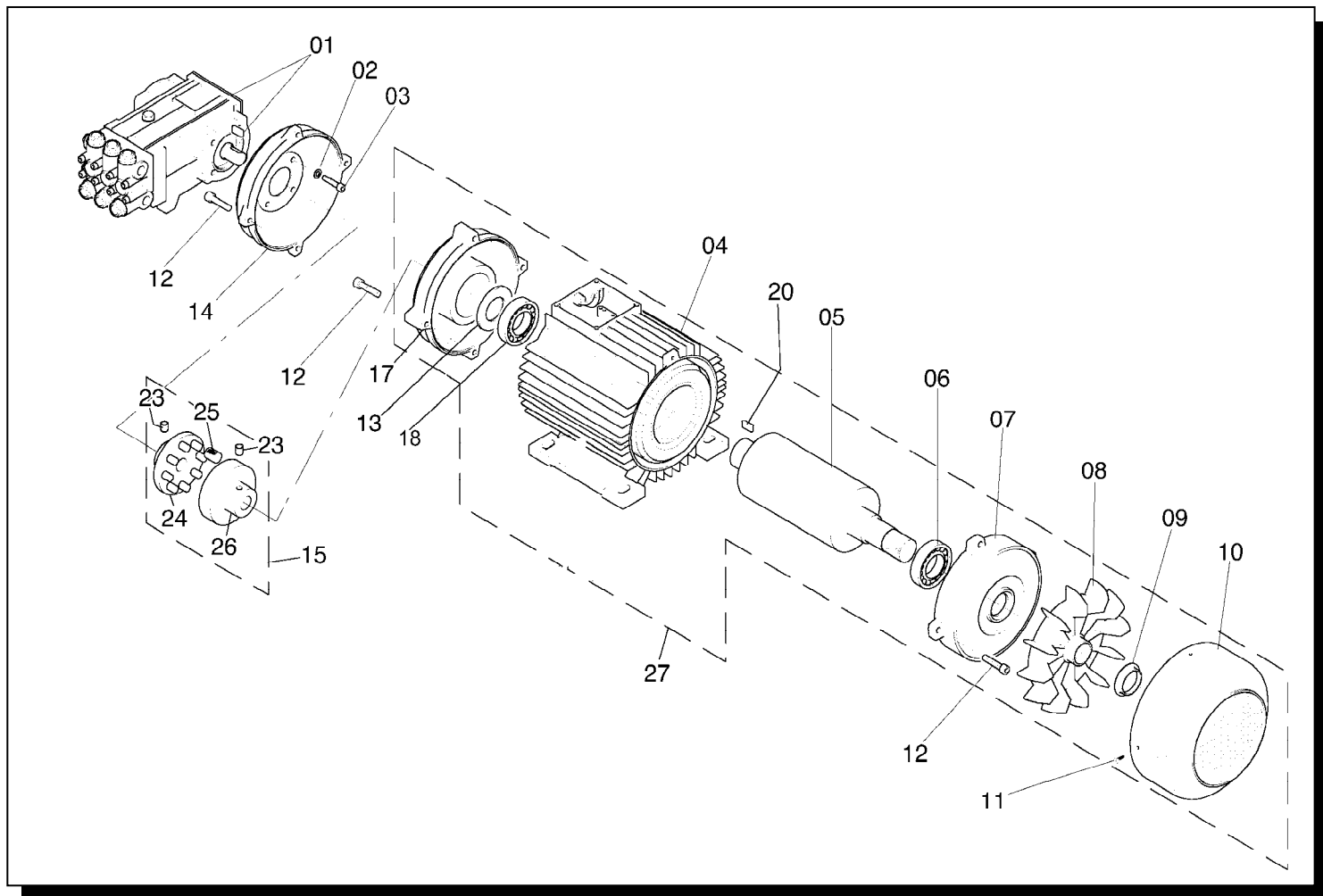

Pos.	Cod.	Descrizione	Description	Descripción	N°
01a	3.015.12.043	Pompa WSF4000	Pump WSF4000	Bomba WSF4000	1
01b	3.015.12.016	Pompa SF5000	Pump SF5000	Bomba SF5000	1
02	4.008.52.002	Rondella	Washer	Arandela	4
03	4.002.11.002	Vite M8x25 "Hawk"	M8x25 screw "Hawk"	Tornillo M8x25 "Hawk"	4
04a	2.017.02.023	Premontato carter WSF4000	Preassembled casing WSF4000	Preensamblado cárter WSF4000	1
04b	2.017.02.021	Premontato carter SF5000	Preassembled casing SF5000	Preensamblado cárter SF5000	1
05a	2.014.02.046	Premontato albero WSF4000	Preassembled shaft WSF4000	Preensamblado eje WSF4000	1
05b	2.014.02.044	Premontato albero SF5000	Preassembled shaft SF5000	Preensamblado eje SF5000	
06a	4.016.02.006	Cuscinetto WSF4000	Bearing WSF4000	Cojinete WSF4000	1
06b	4.016.02.007	Cuscinetto SF5000	Bearing SF5000	Cojinete SF5000	2
07a	1.074.02.007	Flangia posteriore WSF4000	Back flange WSF4000	Brida posterior WSF4000	1
07b	1.074.02.012	Flangia posteriore SF5000	Back flange SF5000	Brida posterior SF5000	1
08a	1.073.02.003	Ventola WSF4000	Fan WSF4000	Ventilador WSF4000	1
08b	1.073.02.005	Ventola SF5000	Fan SF5000	Ventilador SF5000	1
09	1.045.02.005	Fascetta	Clamp	Faja	1
10a	1.046.02.012	Protezione ventola WSF4000	Fan protection WSF4000	Protección ventilador WSF4000	1
10b	1.046.02.017	Protezione ventola SF5000	Fan protection SF5000	Protección ventilador SF5000	1
11	4.002.94.015	Vite autofilettante 3,9x9,5	3,9x9,5 self tapping screw	Tornillo autoblocante 3,9x9,5	4
12	4.002.11.002	Vite M8x25	M8x25 screw	Tornillo M8x25	12
13a	4.049.12.003	Anello WSF4000	Ring WSF4000	Anillo WSF4000	1
13b	4.049.12.004	Anello SF5000	Ring SF5000	Anillo SF5000	1
17a	1.074.02.035	Flangia anteriore WSF4000	Front flange WSF4000	Brida anterior WSF4000	1

COMPLESSIVO MOTOPOMPA – MOTORPUMP LAYOUT – ESQUEMA GENERAL MOTOBOMBA

Pos.	Cod.	Descrizione	<i>Description</i>	Descripción	N°
17b	1.074.02.032	Flangia anteriore SF5000	Front flange SF5000	Brida anterior SF5000	1
15a	3.055.02.002	Giunto WSF4000	Coupling WSF4000	Junta WSF4000	1
15b	3.055.02.001	Giunto SF5000	Coupling SF5000	Junta SF5000	1
16					
14a	1.074.02.034	Flangia WSF4000	Flange WSF4000	Brida WSF4000	1
14b	1.074.02.031	Flangia SF5000	Flange SF5000	Brida SF5000	1
18	4.016.02.011	Cuscinetto WSF4000	Beaing WSF4000	Cojinete WSF4000	1
19					
20	4.021.02.005	Chiavetta	Cotter	Chaveta	1
21					
22					
23	4.004.42.005	Grano	Grub screw	Grano	1
14a	1.131.02.005	Mozzo Ø24 WSF4000	Ø24 hub WSF4000	Cubo Ø24 WSF4000	1
24b	1.131.02.009	Mozzo Ø24 SF5000	Ø24 hub SF5000	Cubo Ø24 SF5000	1
25	1.157.02.001	Ammortizzatore giunto	Coupling cushion	Amortiguador junta	12
26a	1.131.02.006	Mozzo Ø35 WSF4000	Ø35 hub WSF4000	Cubo Ø35 WSF4000	1
26b	1.131.02.010	Mozzo Ø38 SF5000	Ø38 hub SF5000	Cubo Ø38 SF5000	1
27a	3.002.12.033	Motore elettrico WSF4000	Electric motor WSF4000	Motor eléctrico WSF4000	1
27b	3.002.12.030	Motore elettrico SF5000	Electric motor SF5000	Motor eléctrico SF5000	1



KRÜGER TECHNOLOGY S.L.
B-82526583
Polígono Agustinos C/G Parcela B2
31013 Pamplona (Navarra) - ESPAÑA
+34 948 343 393 - info@kruger.es - www.kruger.es