



DESPIECE TÉCNICO

HIDROLIMPIADORA

KHL1108C



DESPIECE HIDROLIMPIADORA KHL1108C

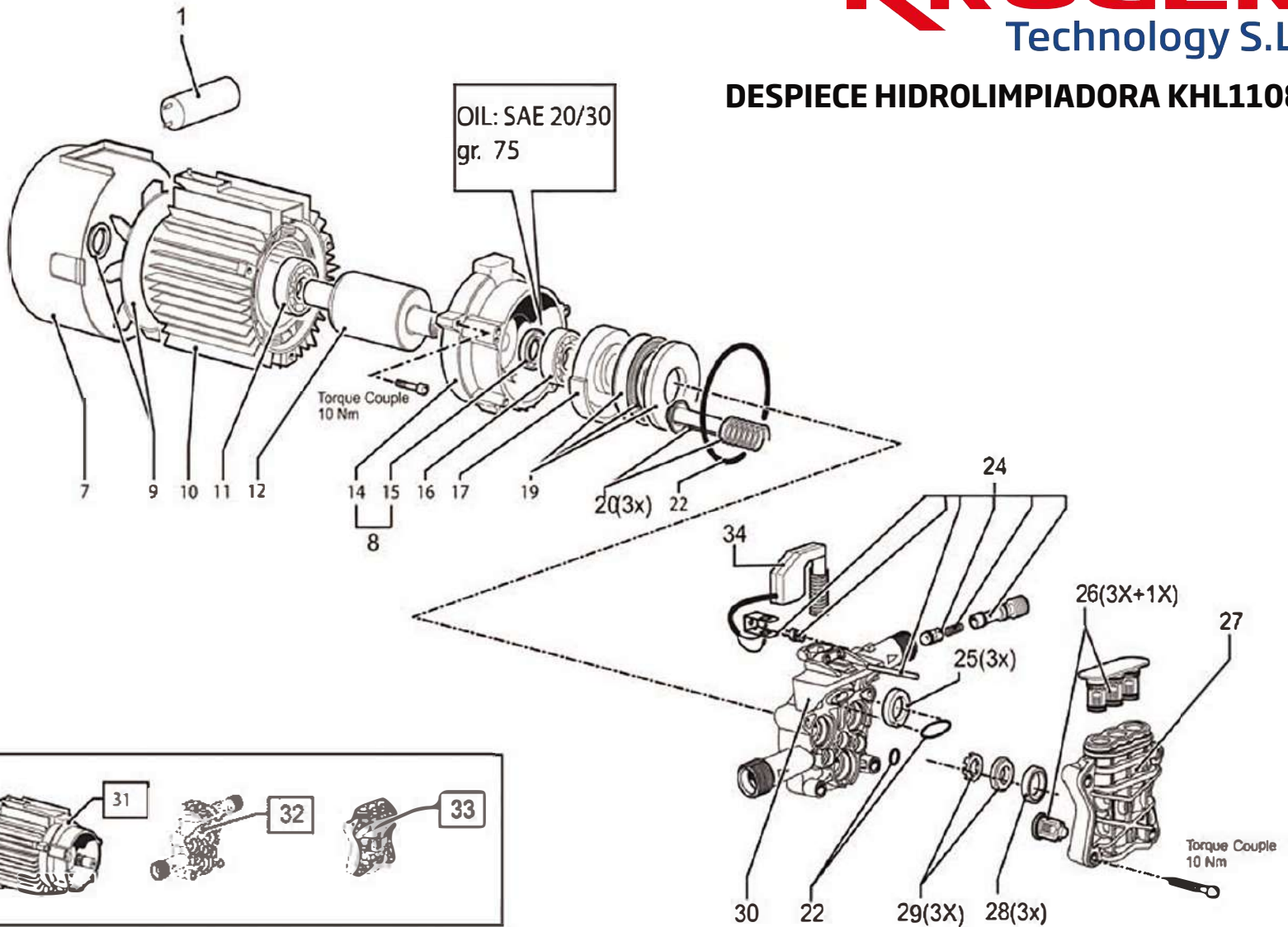

DESPIECE HIDROLIMPIADORA KHL1108C

CODICE:	DESCRIZIONE:	QTA:	POS:	RIF1:	RIF2:
5.001.0569	MOTORPUMP	1	00		
3.404.0017	25 MF 450V CAPACITOR 39x94	1	01		
4.008.0583	MOTOR FAN COVER '96 WITHOUT GRILL	1	07		
5.009.0533	FRONT FLANGE '96 D.110 W/RING	1	08		
6.005.0253	KIT 236 LW FAN + RING	1	09		
5.002.0130	MOTOR HOUSING '02 D110 H100 2P	1	10		
3.001.0020	RADIAL FOR POSTERIOR FLANGE 17X40X12 6203 2RS	1	11		
5.005.0049	ROTOR D.55 H.100 CIL ESP.00	1	12		
4.005.0219	FRONT FLANGE D.110 PT'03 ESP.01	1	14		
3.201.0008	OIL SEALING RING D. 17X35X7	1	15		
3.001.0030	RADIAL	1	16		
4.005.0218	WOBBLE PLATE 9'35 PT'03 ESP.02	1	17		
6.005.0087	KIT 87 LW	1	19		
6.005.0181	KIT 167 LW PISTON	1	20		
6.005.0226	KIT 209 O-RING	1	22		
6.005.0183	KIT 169 LW INJECTOR 1,7	1	24		
6.005.0079	KIT 79 LW OIL SEALS	1	25		
6.005.0184	KIT 170 LW HEAD VALVE KIT	1	26		
4.005.0210	'03 PARTNER HEAD REV.11	1	27		
6.005.0133	KIT 124 O-RING WATER SEAL PARTNER D.12	1	28		
6.005.0134	KIT 125 O-RING SEAL	1	29		
4.005.0211	PISTON BODY GUIDE PT'03 ESP00	1	30		
5.006.0188	MOTOR	1	31		
5.007.0187	BODY GUIDE PT'03 PISTONS D.12 W/ASS,DETERG.SUCTION	1	32		
5.008.0182	'03 PARTNER HEAD D.12	1	33		
5.009.0537	COMPLETED VALVE TS PT'03 CABLE L=510 SPRING 13KG	1	34		
3.403.0054	THERMAL PROTECTOR CD2A170D F/F F/M 6,3	1	35		

DESPIECE HIDROLIMPIADORA KHL1108C

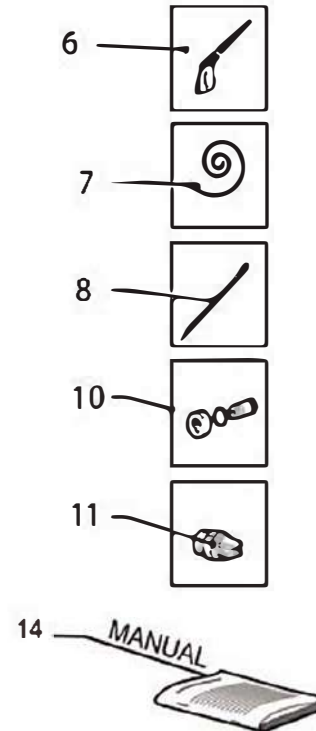
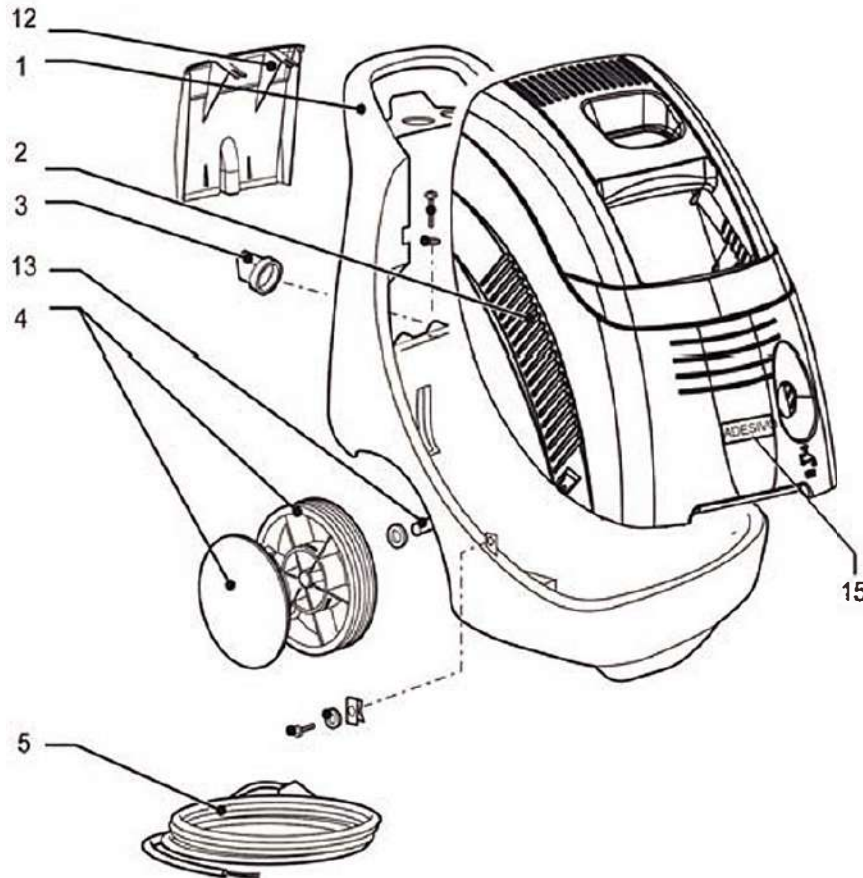

DESPIECE HIDROLIMPIADORA KHL1108C

CODICE:	DESCRIZIONE:	QTA:	POS:	RIF1:	RIF2:
4.608.0142	PLASTIC BASE FOR PARANA'	1	01		
4.613.0175	UPPER COVER FOR MUSSOURI -G- RAL. 1018	1	02		
4.608.0027	CAP DIAM.30 FOR TANK FIRE 100	3	03		
6.605.0018	WHEELS KIT + STUDSO.250	1	04		
5.009.0431	WIRING PARTN. 3X1,5 PVC MT 5 SCHUKO PLUG	1	05		
6.001.0053	HP SPRAY GUN S'02 3/8" ESP.02	1	06		
4.618.0084	B.P. 1/2 HOSE	1	07		
6.002.0309	LANCE A/B 1.10 M22	1	08		
5.009.0340	QUICK COUPLING ASSY +GASKET+RING NUT	1	10		
3.103.0048	HIGH PRESSURE NOZZLE 15035 1/8M (C25035)	1	11		
4.613.0176	REAR PLASTIC COVER MISSOURI -G- RAL 1018	1	12		
4.607.0220	AXLE FOR VICTORIA-PARANA'	1	13		
7.700.0250	INSTRUCTION MANUAL MEK 1108	1	14		
7.701.1648	STICKER MEK LAVOR 230x50 2C	1	15		

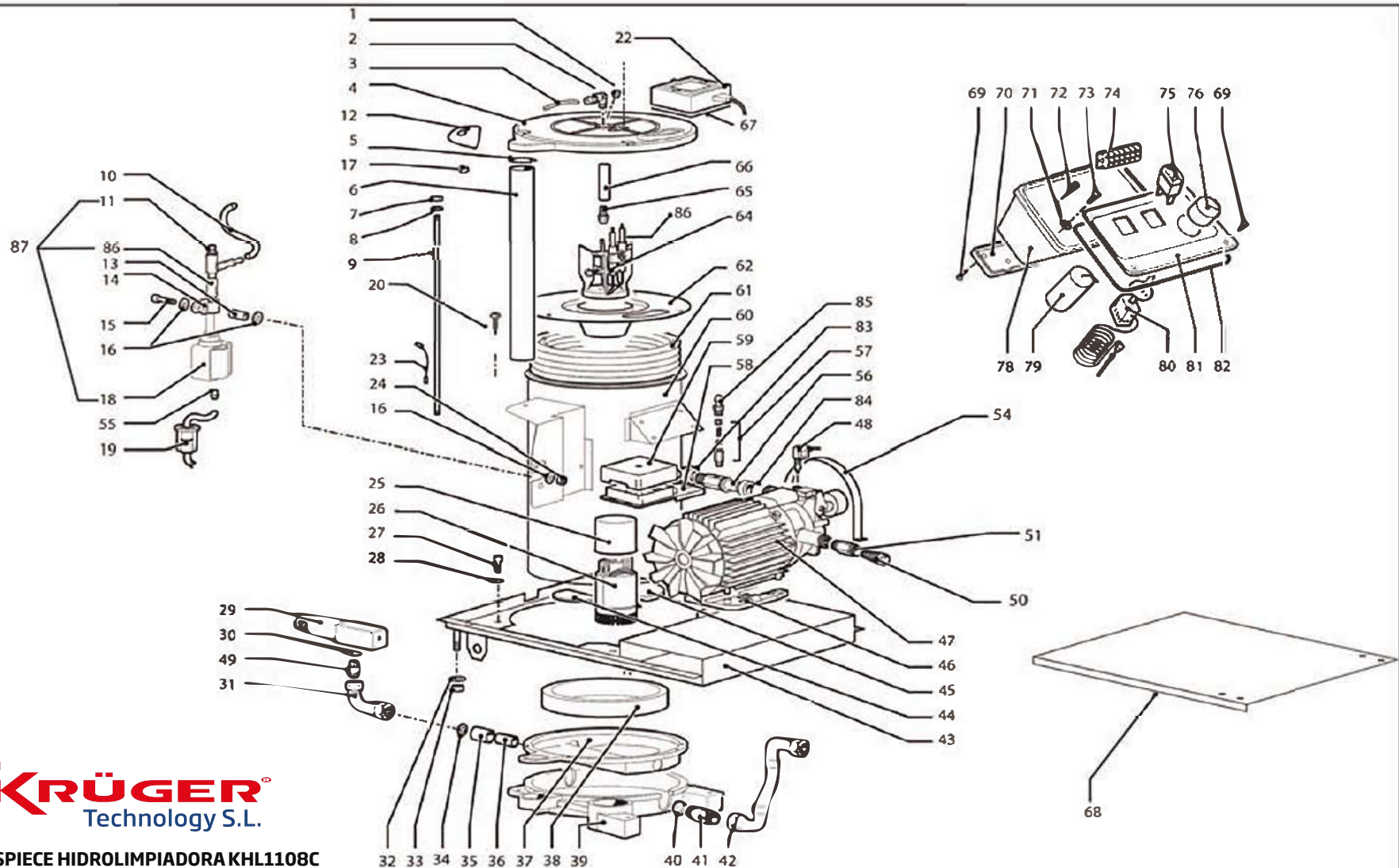

KRÜGER
Technology S.L.

DESPIECE HIDROLIMPIADORA KHL1108C

DESPIECE HIDROLIMPIADORA KHL1108C

CODICE:	DESCRIZIONE:	QTA:	POS:	RIF1:	RIF2:
3.002.0159	SCREW M6X6	1	01		
3.100.0075	CONIC CONNECTION M 1/8 F D,4 CURVED FOR GASOIL HOSE VITON O-RING	1	02		
4.608.0145	RILSAN GASOIL HOSE X PARANA' L =500 ESP.00	1	03		
4.005.0194	CAP FOR BOILER FFK	1	04		
3.099.0124	RING LOCKER X SHAFT D.42 UNI 7435	1	05		
4.607.0236	HOSE D40 L=410	1	06		
3.003.0011	NUT M6 UNI 5588	3	07		
3.004.0010	WASHER D6X11 Sp0,7 DIN6798A ZN T	3	08		
4.607.0238	ROD FOR BOILER	3	09		
4.008.0465	PVC PIPE	2	10		
3.100.0057	CONNECTION D.4X1/8" M VITON O-RING	1	11		
4.008.0748	BOILER LOCKING CAP FOR FFK REGULATION ESP.00	1	12		
4.007.0185	SPACER FOR FIXING CLAMP	1	13		
3.099.0452	WRAPPER D.20 CLAMP 20 W2	1	14		
3.002.0085	SCREW M6X40 UNI 5739	1	15		
3.004.0001	WASHER D.6X11	2	16		
4.008.0749	AIR REGULATION THROTTLE FOR FK X ESP.00	1	17		
3.551.0023	DIESEL PUMP V.P. E153823 230 /50 CABLES L=400mm W/6Y-PASS	1	18		
5.011.0058	GAS OIL FILTER ASSY	1	19		
3.002.0048	AUTOTHREAD. SCREW TC-TC 3,9X38 UNI 6954	2	20		
3.004.0002	WASHER 4.3X9	2	21		
3.400.0027	TRANSFORMER 230-240/50-60	1	22		
4.012.0102	CABLE L=600 SEC.0,75 IEC227-3/1979	2	23		
3.003.0005	SELF-LOCKING NUT M6 UNI7474	1	24		
4.008.0470	FAN MOTOR COVER	1	25		
3.304.0005	BURNER MOTOR 230/50 C/W FAN, FLANGE, CABLES AND COVER	1	26		
3.002.0138	SCREW TCEI M6X20 ZNT UNI 5931	4	27		
3.004.0007	WASHER 6X18 UNI 6593 ZNT	3	28		
4.606.0191	OUTLET JOINT	1	29		
3.004.0036	COPPER WASHER 3/8 17X22 SP.1.5	2	30		
3.100.0094	ANGLE CONNECTOR 3/8 -3/8	1	31		
3.004.0007	WASHER 6X18 UNI 6593 ZNT	4	32		
3.003.0005	SELF-LOCKING NUT M6 UNI7474	4	33		
4.007.0200	WASHER20.2X26X3	1	34		
4.007.0184	COUPLING PIPE FOR PARANA'	1	35		
4.008.0449	THERMORESISTANT COUPLING BOW 17X23XL40	1	36		
4.007.0158	BOILER PAD	1	37		
4.008.0503	BAND IN CERAMIC FIBER	1	38		
4.605.0042	BASE FOR PARANA' BOILER	1	39		
4.007.0200	WASHER20.2X26X3	1	40		
4.607.0237	RUBBER HOSE COUPLING FOR COIL	1	41		
4.618.0067	HOSE 5/16 RI 15DEG. 250 BAR 3/8 F ROT.-3/8 F ROT.	1	42		
5.613.0154	MOTOPUMP-BOILER SUPPORT FOR PARANA'	1	43		
4.008.0450	THERMORESISTANT PAD	1	44		
4.008.0658	THERMORESISTANT FELT BOTTOM PL ATE X FFK/PARANA' ESP.02	1	45		

DESPIECE HIDROLIMPIADORA KHL1108C

CODICE:	DESCRIZIONE:	QTA:	POS:	RIF1:	RIF2:
4.008.0514	BLACK EAGLE FOOT FOR MOTOR- PUMP SUPPORT	1	46		
5.001.0569	MOTORPUMP	1	47		
3.704.0007	PRESSURE SWITCH PR5 25BAR 1/8M L.550	1	48		
3.100.0023	NIPPLE 3/8 CIL. SV. 3/8 CIL. SV	1	49		
4.008.0031	INLET WATER FILTER H2O D.16 CONICAL	1	50		
4.006.0181	WATER INLET SPACER	1	51		
3.004.0007	WASHER 6X18 UNI 6593 ZNT	2	52		
3.002.0138	SCREW TCE1 M6X20 ZNT UNI 5931	2	53		
4.007.0223	EAGLE MOTOR-PUMP BAND	1	54		
4.007.0307	JUNCTIONESP.02	1	56		
3.106.0004	SECURITY VALVE G1/8 M D6 200BAR MTM 00036021	1	57		
4.608.0141	ELECTRICAL BOX BASE FOR MOTOPIUMP	1	58		
4.608.0140	ELECTRICAL BOX COVER FOR MOTOPIUMP	1	59		
5.613.0155	BOILER BODY FOR PARANA'	1	60		
4.604.0017	COIL D.202 FOR PARANA'	1	61		
5.013.0027	DISK HEAD HOLDER	1	62		
4.012.0177	CABLE AND EYELET	1	63		
3.099.0297	COMPLETE DEFLECTOR	1	64		
3.104.0008	GAS OIL NOZZLE 0.60 60/A MONEL FILTER	1	65		
4.006.0187	NOZZLE HOLDER PIN	1	66		
5.611.0101	CABLE	2	68		
3.002.0110	SCREW 3,9X19	7	69		
4.608.0071	GUIDING CABLE COVER DASHBOARD '93	1	70		
3.004.0017	WASHER D.5X10	4	71		
3.002.0110	SCREW 3,9X19	2	72		
3.002.0176	SCREW MSX16 7985	4	73		
3.405.0011	TERMINAL BOARD PA 32/6	1	74		
5.009.0538	SWITCH ASSY + PROTECTION COVER 14 (14)	2	75		
4.608.0164	THERMOSTAT KNOB	1	76		
4.608.0065	BOX DASHBOARD '93	1	78		
3.404.0016	CAPACITOR 45mF 450V D.45X90 WITHOUT CABLE FASTON M	1	79		
3.403.0032	THERMOSTAT 30/90 FOR PARANA'	1	80		
4.608.0207	DASHBOARD	1	81		
4.608.0078	GASKET	1	82		
4.006.0283	FERRULE M22x1,5 L=16.	1	83		
3.200.0001	O-RING GASKET 9,92X2,62 RIF.11 2	1	84		
4.606.0088	RUBBER HOLDER 1/4 G M D.7	1	85		



KRÜGER TECHNOLOGY S.L.
B-82526583
Polígono Agustinos C/G Parcela B2
31013 Pamplona (Navarra) - ESPAÑA
+34 948 343 393 - info@kruger.es - www.kruger.es