



**CATALOGO PARTI DI RICAMBIO
SPARE PARTS CATALOGUE
CATALOGUE DES PIECES DETACHEES
CATÁLOGO DE RECAMBIOS**





KH3515

INTRODUZIONE

La presente pubblicazione contiene le illustrazioni dei particolari che compongono la macchina, nonché i numeri di codice dei particolari di ricambio.

INDIVIDUAZIONE DELLE PARTI

La presente pubblicazione è suddivisa in gruppi che riguardano la composizione della macchina (es: telaio, fissaggi, impianti, pompa, motore ecc.). Osservare la figura, individuare il n° di riferimento del pezzo ed il corrispondente n° di codice (Cod.) occorrente per l'ordinazione del particolare.

Segni particolari come potrebbero essere      ecc., indicano l'appartenenza ad un kit di ricambio o che il particolare va bene solo per uno specifico modello.

NORME PER LE ORDINAZIONI

Le ordinazioni delle parti di ricambio debbono essere corredate dalle seguenti indicazioni: **tipo di macchina, modello, n° di matricola, anno di costruzione, n° di pagina della tavola, n° di riferimento del particolare, n° di codice del particolare, quantità dei pezzi occorrenti per ciascun n° di codice.**

ATTENZIONE

Ferme restando le caratteristiche essenziali del tipo, la nostra azienda si riserva il diritto di apportare modifiche che ritenesse convenienti a scopo di miglioramento o per qualsiasi altra esigenza di carattere costruttivo o commerciale, anche senza aggiornare il presente catalogo.

 **WS 200.21**

 **XW 280.21**

 **W 200.30**

 **XW 350.15**





 **XW 200.21**

 **XW 300.21**

INTRODUCTION

The publication contains the illustrations of the items that compose the machine and the code numbers of the spare parts.

INDIVIDUALIZATION OF THE PARTS

The catalogue is subdivided in groups concerning the parts that compose the machine (for example: frame, fixings, diagrams, pump motor etc.). See the illustrations, find the reference number of the part and the code number (Cod.) necessary to order the part. Conventional marks as      etc., indicate that the part is a component of a repair kit or that the same is a part of a particular type

or model of the machine or part of a particular type of component.

REMARKS FOR THE ORDERING

The order of spare parts must include the following details: **machine type, serial number, manufacturing year, page number, reference number, code number, quantity of the parts for each code number.**

WARNING

Where the main characteristics of the model remain unchanged, our company reserves the right to bring about all modifications which are considered convenient for improvement or for any other constructive or commercial requirement, without obligation to bring opportunely up-to date the present spare parts catalogue.

 **WS 200.21**

 **XW 280.21**

 **W 200.30**

 **XW 350.15**

 **XW 200.21**

 **XW 300.21**

INTRODUCTION

Cette catalogue contient les illustrations des particuliers qui composent la machine et les numéros de code des pièces de rechange.

INDIVIDUALISATION DES PIÈCES

Le catalogue est subdivisé en groupes des pièces qui composent la machine (comme pour exemple: châssis, fixations, systèmes, pompe, moteur, etc.). Voir la table illustrée, individuer le numéro de référence de la pièce et le correspondant numéro de codification (Cod.) pour la commande. Les signes conventionnels comme les suivantes, \triangle \blacktriangle \blacksquare \square \circ etc., indiquent l'appartenance à un kit de réparation ou à une particulier type ou modèle de machine ou de composante de la même.

REGLES POUR LA COMMANDE

Les commandes des pièces doivent nous parvenir complètes des indications suivantes: **type de la machine, modèle, numéro de série, année de construction, numéro de la page, numéro de référence de la pièce, numéro de codification (Cod.) de la pièce, quantité des pièces pour chaque numéro de codification.**

ATTENTION

Sans modifications des caractéristiques essentielles du type, notre maison, se réserve le droit d'apporter les modifications retenues convenables dans le but d'améliorer ou pour n'importe quelle autre exigence de caractère constructif ou commercial, même sans mettre à jour le présent catalogue.

\blacktriangle WS 200.21

\triangle XW 280.21

\blacksquare W 200.30

\square XW 350.15

\bullet XW 200.21

\circ XW 300.21

INTRODUCCION

Este catálogo, contiene las ilustraciones de las despieces de la máquina y los números de código de las piezas de repuesto.

AVERIGUACION DE LOS DESPIECES

El catálogo, está subdividido en grupos que muestran los despieces que componen la máquina (como por ejemplo: chasis, circuitos, motor, bomba, etc.). Ver la tabla ilustrada, individuar el número de referencia de la pieza y el número de código (Cod.) de la misma, que sirve para preparar el pedido. Signos convencionales como pueden ser, \triangle \blacktriangle \blacksquare \square \circ etc., indican que el despiece es un componente de un kit de reparación o que el mismo es una pieza de repuesto solo para uno específico modelo o tipo de máquina o de un particular componente.

NORMAS PARA EL PEDIDO DE LOS DESPIECES

Los pedidos nos deberan de llegar completos de las siguientes indicaciones: **tipo de la máquina, modelo de la misma, número de serie, año de construcción, número de la página del catálogo, número de referencia del despiece, número de código del despiece, cantidad de piezas para cada uno de los números de código.**

ATENCION

Aun manteniendo las características principales de la máquina, nuestra empresa, se reserva el derecho de aportar las modificaciones retenidas convenientes con el fin de mejorar o para cualquiera otra exigencia de carácter constructivo o comercial, sin actualizar el presente catálogo.

\blacktriangle WS 200.21

\triangle XW 280.21

\blacksquare W 200.30

\square XW 350.15

\bullet XW 200.21

\circ XW 300.21

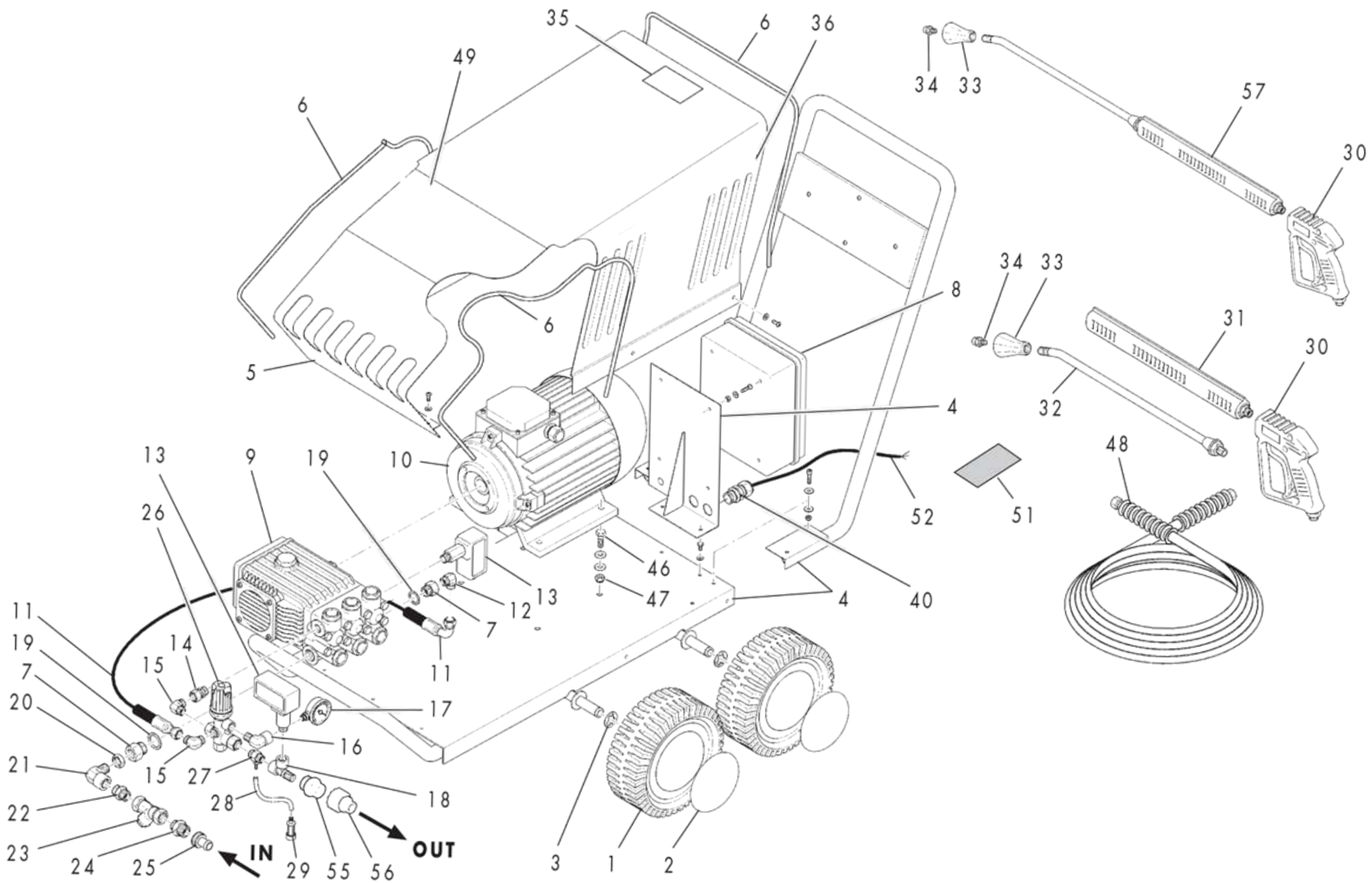

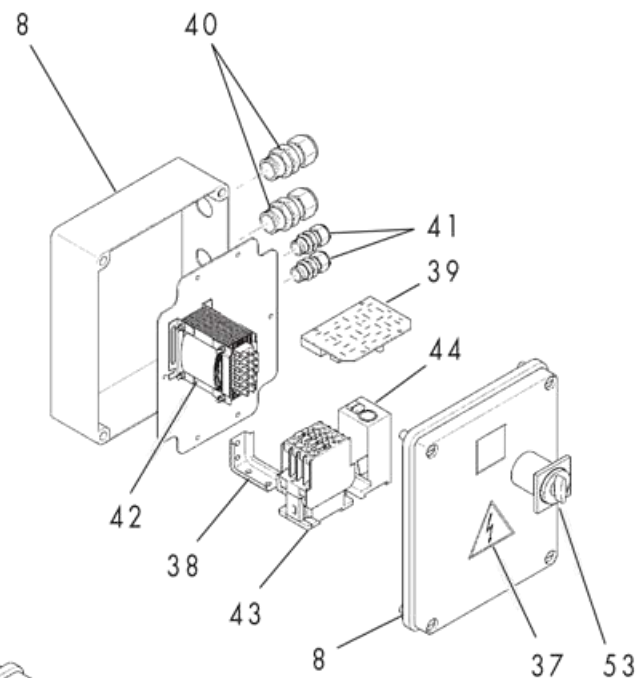
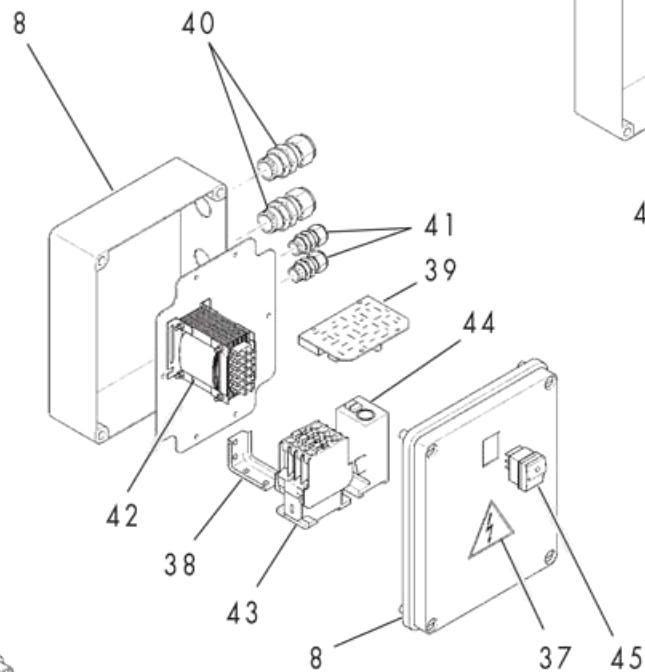
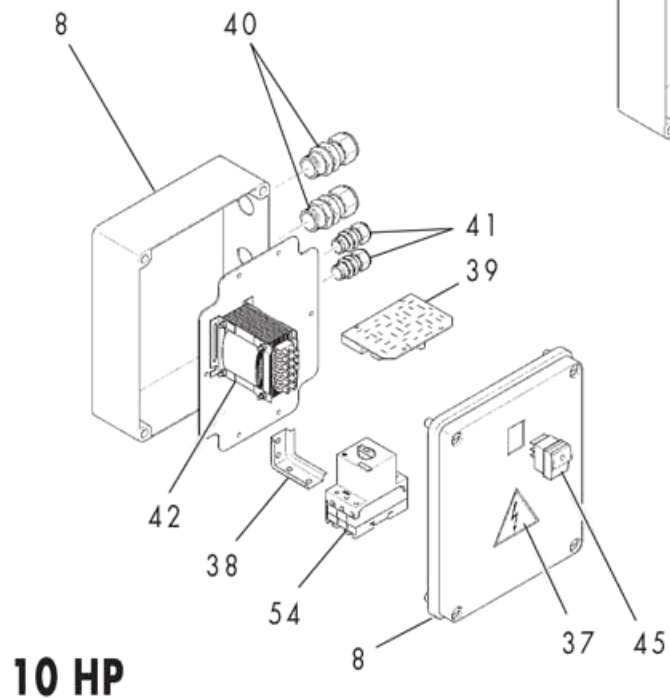

Pos.	Cod.	Q.Ty	Descrizione	Description	Description	Descripción	Note	€
1	4400115	4	Ruota gomma piena	Wheel	Roue	Rueda	Diam. 260	
2	4400116	4	Borchia per ruota	Wheel cap	Couvercle	Tapa rueda	Diam. 260	
3	1000008	4	Molla fermaruota	Wheel lock spring	Rondelle de blocage	Arandela de bloqueo	Diam. 20	
4	5452110	1	Telaio completo	Complete frame	Chassis complete	Chasis completo		
5	5452000	1	Scocca completa	Complete cover	Capot complete	Cubierta completa		
6	4000080	—	Profilo per scocche	Cover profile	Joint pour capot	Guarnición cubierta	lg. tot. mm. 2.500 (mm.14)	
7	1400405/Z	2	Riduzione	Reduction	Reduction	Reducción	3/4M - 1/2F Z241	
8	2000276	1	Scatola stagna	Electric box	Boîte	Caja		
9	6000240	1	Pompa acqua	Water pump	Pompe eau	Bomba agua	WS 202 ▲	
9	60002030	1	Pompa acqua	Water pump	Pompe eau	Bomba agua	W 2030 ■	
9	6000859	1	Pompa acqua	Water pump	Pompe eau	Bomba acqua	XW 21.20 ●	
9	A21136	1	Pompa acqua	Water pump	Pompe eau	Bomba acqua	XW 21.28 △	
9	A20807	1	Pompa acqua	Water pump	Pompe eau	Bomba acqua	SXW 15.35 □	
9	A20808	1	Pompa acqua	Water pump	Pompe eau	Bomba acqua	SXW 21.30 ○	
10	6000370	1	Motore	Motor	Moteur	Motor	HP 10 ▲●	
10	6300370	1	Motore	Motor	Moteur	Motor	HP 17 ■△□○	
11	6100170	1	Tubo AP uscita	H.P. Hose	Tuyau H.P.	Tubo A.P.	085	
12	1000256	1	Curva ottone	Elbow coupling	Raccord a coude	Empalme a codo	1/2M - 3/8M	
13	6100140	2	Pressostato	Pressure switch	Pressostath	Presostato	300 bar ▲△●■	
13	P29000000	2	Pressostato	Pressure switch	Pressostath	Presostato	600 bar □○	
14	1000223	1	Nipplo con girello	Nipple with swivel	Nipple tournant	Niplo girador	3/8M/F	
15	1000260	2	Curva ottone	Elbow coupling	Raccord a coude	Empalme a codo	3/8MM	
16	1000244	1	Curva ottone	Elbow coupling	Raccord a coude	Empalme a codo	1/4MF	
17	1000338	1	Manometro	Pressure gauge	Manomètre	Manómetro	Diam 50 (PK)	
18	1000273	1	Raccordo a T	T coupling	Raccord en T	Empalme a T	3/8F - 3/8F - 3/8M	
19	1000622	2	Rondella allum.	Washer	Rondelle	Arandela	3/4 27x32x1,5	
20	1000791	1	Controdado ott.	Nut	Ecrou	Tuerca	1/2	
21	1000246	1	Curva ottone	Elbow coupling	Raccord a coude	Empalme a codo	1/2MF	
22	1000430	1	Nipplo zincato	Niple	Nipple	Niplo	1/2	
23	1000250	1	Filtro acqua a Y	Y water filter	Filtre eau en Y	Filtro acqua a Y	1/2	

Pos.	Cod.	Q.Ty	Descrizione	Description	Description	Descripción	Note	€
24	1000830	1	Nipplo ridotto	Nipple	Nipple	Niplo	3/4M - 1/2M	
25	1000239	1	Portagomma girello	Suction fitting	Raccord aspiration	Empalme aspiración	3/4 GF17	
26	6000119	1	Valvola di regolazione	Pressure reg. valve	Soupape de réglage	Valvula de regulación	MG 4000 ● △	
26	6000103	1	Valvola di regolazione	Pressure reg. valve	Soupape de réglage	Valvula de regulación	MV 565 ▲	
26	6000113	1	Valvola di regolazione	Pressure reg. valve	Soupape de réglage	Valvula de regulación	VB9 ■	
26	P60170000	1	Valvola di regolazione	Pressure reg. valve	Soupape de réglage	Valvula de regulación	VB 350 □ ○	
27	6000068	1	Eiettore fisso "Kim jet"	Kim-jet	Kim-jet	Kim-jet	MV 200 - 2,1	
28	4000134	1	Tube cristallo	Detergent hose	Tuyau detergent	Tube detergente	mm. 1.000	
29	A1341030	1	Filtro aspir. detergente	Detergent filter	Filtre detergent	Filtro detergente	FD	
30	6000020	1	Idropistola	Spray gun	Pistolet	Pistola	MV 880 ▲ ■ ● △	
30	6000030	1	Idropistola	Spray gun	Pistolet	Pistola	MV 940 □ ○	
31	6000057	1	Impugnatura	Handle	Poignée	Empuñadura	MT2+AR M22 ▲ ■ ● △	
32	6000056	1	Terminale lancia	Lance end	Terminal lance	Terminal lanza	mm. 700 ▲ ■ ● △	
33	6000050	1	Testina regolabile	Adjusting head	Tête réglable	Cabeza regulable	TPR50 - 1/4	
34	1000300	1	Ugello acqua	Water nozzle	Buse a eau	Boquilla de agua		
35	4280043	1	Adesivo istruz.	Adhesive	Adhesif	Adhesivo	PVC 3 col.	
36	4280005	2	Adesivo	Adhesive	Adhesif	Adhesivo		
37	4280028	1	Adesivo (sotto tensione)	Adhesive	Adhesif	Adhesivo	Triang. YK	
38	5400065	1	Omega per telerutt.	Bracket	Etrier	Estribo	Zincata	
39	2000161	1	Scheda TSI	TSI PCB	Fiche électronique TSI	Tarjeta TSI	A freddo	
40	2000085	3	Pressacavo	Cable gland	Collier câble	Prensacable	PG16	
41	2000073	2	Pressacavo	Cable gland	Collier câble	Prensacable	PG7 BS7 nero	
42	2400215	1	Trasformatore	Transformer	Transformateur	Transformador	50 VA	
43	2000059	1	Contattore	Contacteur	Contacteur	Contacteur	KN30 - 400V	
44	2000062	1	Relè termico	Relè	Relais	Relé	24/40	
45	2000070/24	1	Interruttore luminoso	Switch	Interrupteur	Interruptor	24V	
46	1000550	4	Vite TE	Screw	Vis	Tornillo	M10x30 zinc.	
47	1000710	4	Dado	Nut	Ecrou	Tuerca	M10 zinc.	
48	6400035/1	1	Tube A.P.	H.P. hose	Tuyau H.P.	Tube A.P.	5/16 - 315 bar - MT.10 A3/8" ▲ ■ ● △ ○	
48	6000135	1	Tube A.P.	H.P. hose	Tuyau H.P.	Tube A.P.	3/8 R2 - 400 bar - MT.10 A3/8" □	

Pos.	Cod.	Q.Ty	Descrizione	Description	Description	Descripción	Note	€
49	4400057	1	Adesiva Maxi	Adhesive	Adhesif	Adhesivo		
50	4000174	1	Adesiva	Adhesive	Adhesif	Adhesivo	200/280/300/350	
51	5000015	1	Adesiva dati tecnici	Adhesive	Adhesif	Adhesivo	Argento indeleb.	
52	2000053	1	Cavo antifiamma	Electric cable	Câble électrique	Cable eléctrico	mm. 8.000 (4x2,5)	
53	2000340	1	Interruttore	Switch	Interrupteur	Interruptór	PL1	
54	A1382060	1	Interruttore	Switch	Interrupteur	Interruptór	Magnetotermico 16/20	
54	A1382010	1	Interruttore	Switch	Interrupteur	Interruptór	Magnetotermico 20/25	
55	1000281	1	Raccordo	Joint	Raccord	Empalme	MVG 06	
56	1000285	1	Attacco rapido	Quick coupling	Connexion rapide	Empalme rapido	MVG 8	
57	P40026450	1	Lancia	Lance	Lance	Lanza	S3 INOX 350 bar □ ○	

La nostra Azienda, si riserva il diritto di apportare, in qualsiasi momento, eventuali modifiche per motivi di carattere tecnico o commerciale pertanto, le informazioni, le descrizioni e le illustrazioni contenute in questa pubblicazione sono aggiornate fino al momento dell'approvazione per la stampa.

ATTENZIONE

Le rappresentazioni grafiche delle parti nelle illustrazioni contenute nel presente testo, potrebbero essere diverse dai particolari effettivamente montati sulla macchina, solo il numero di codice (Cod.) rilevabile sul presente catalogo parti di ricambio, determina la validità del pezzo.

Our Company, reserves the right to introduce at any time, eventual changes for technical or commercial reasons, therefore informations, descriptions and illustrations contained in this publication, are updated until their approval for the printing.

WARNING

The graphic illustration of the parts can be different from the detail mounted on the machine, only the code number (Cod.) on this spare parts catalogue, determinates the spare parts validity.

Notre Societé, se réserve le droit d'introduire à n'importe quel moment, toute variations pour raison de caractère technique ou commerciale donc, les informations, les descriptions et les illustrations contenues dans ce manuel, sont mises à jour jusqu'au moment de l'approbation pour l'impresión.

ATTENTION

La représentation graphique de les pièces peut être differente du particulier montée sur la machine, seul le numéro de code (Cod.) relevable sur cette catalogue des pieces detachées, determine la validité de la pièce.

Nuestra Empresa, se reserva el derecho de efectuar, en cualquier momento, modificaciones de carácter técnico o comercial, por lo tanto las informaciones, descripciones e ilustraciones contenidas en esta publicación, estan actualizadas hasta el momento de la aprobación para la impresión de la misma.

ATENCIÓN

La presentación grafica de los despieces en las ilustraciones, puede ser diferentes a los particulares montados en la máquina, solo el número de código del despieces (Cod.) que se puede relevar en este catalogo de recambios, determina la validad de la pieza.

Edizione a cura del costruttore. - Edited by the manufacturer - Edité par le constructeur. - Edición a cargo del constructor.

Data di edizione - Date of issue - Date de édition - Fecha de edición

13/07/2005



KRÜGER TECHNOLOGY S.L.
B-82526583
Polígono Agustinos C/G Parcela B2
31013 Pamplona (Navarra) - ESPAÑA
+34 948 343 393 - info@kruger.es - www.kruger.es