

Idropulitrice KH2030F 30/200 400V (50Hz)

High Pressure Washer KH2030F 30/200 400V (50Hz)

Hochdruck Reiniger KH2030F 30/200 400V (50Hz)

Hidrolimpiadora KH2030F 30/200 400V (50Hz)

Nettoyeuse haute Pression KH2030F 30/200 400V (50Hz)

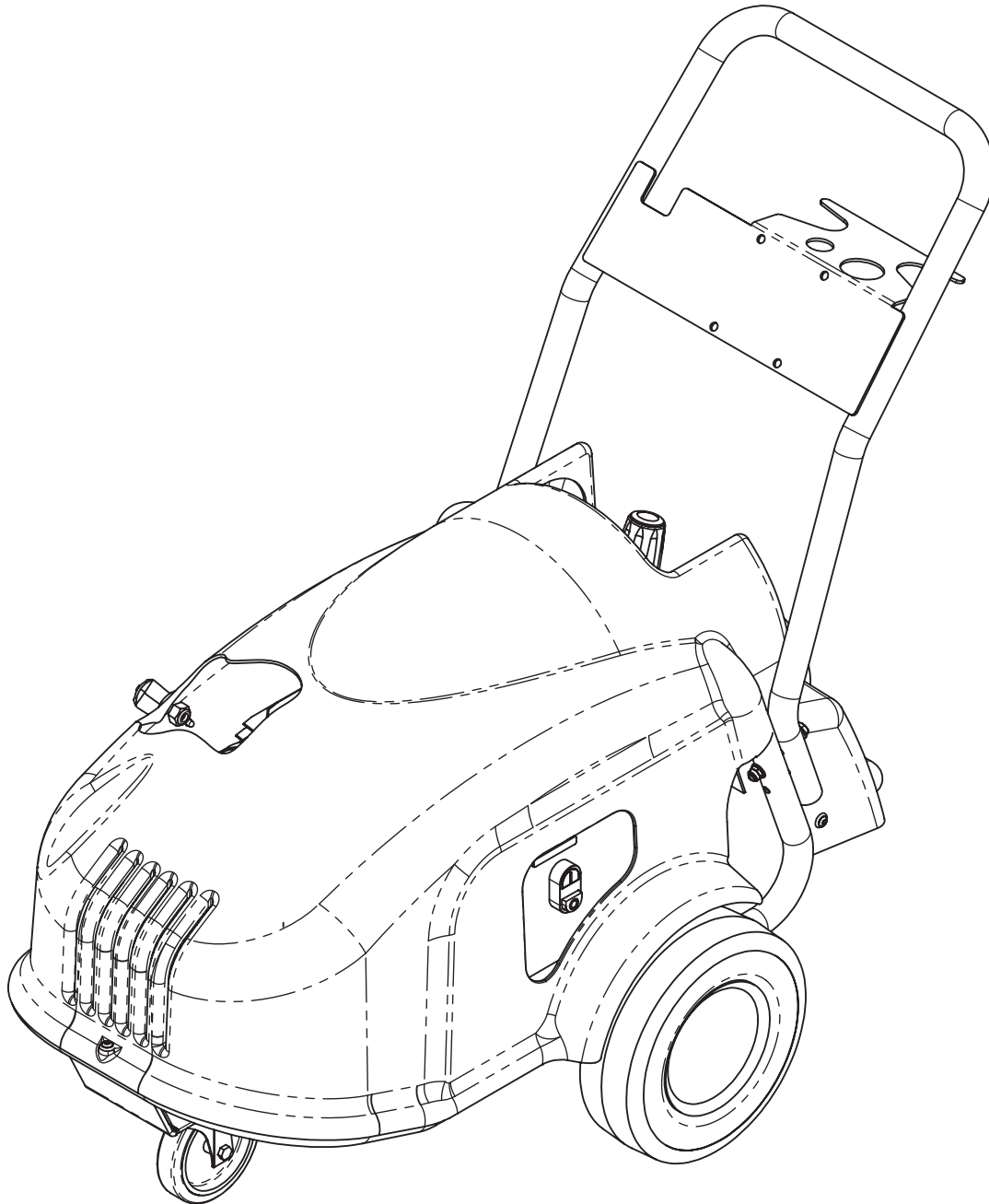

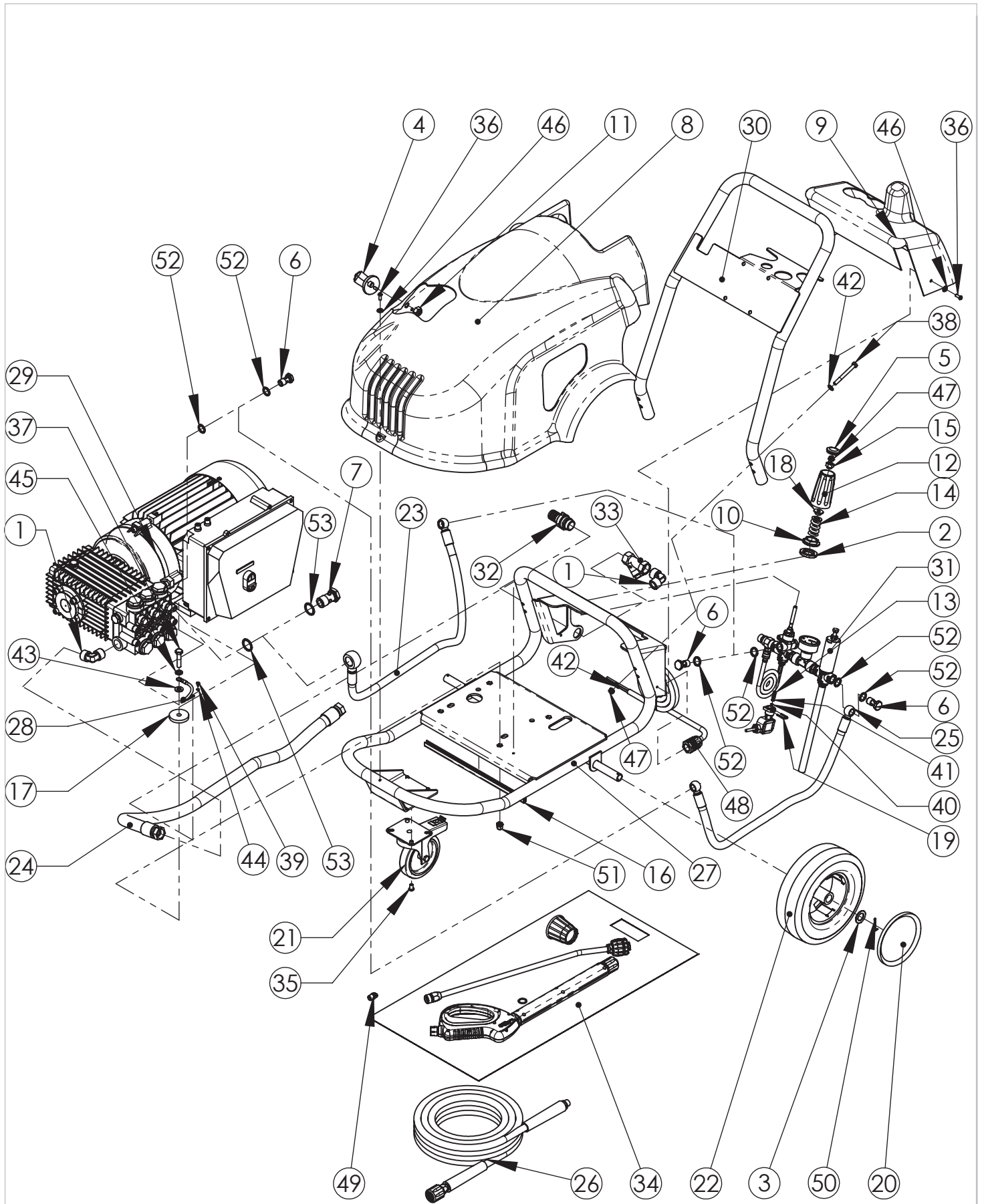

Idropulitrice KH2030F 30/200 400V (50Hz)

High Pressure Washer KH2030F 30/200 400V (50Hz) Hochdruck Reiniger KH2030F 30/200 400V



(50Hz) Hidrolimpiadora KH2030F 30/200 400V (50Hz) Nettoyeur haute Pression KH2030F 30/200

400V (50Hz)

Pos.	Q.tà	Cod.	ITALIANO	INGLESE	TEDESCO	SPAGNOLO	FRANCESE
1	2	1.001.14.026	Raccordo a L 3/4G	L Connection 3/4G	Leiste L 3/4G	Filete L 3/4G	Filet L 3/4G
2	1	1.003.04.009	Rondella VBR KC5000	Washer VBR KC5000	Unterlegscheibe VBR KC5000	Arandela VBR KC5000	Rondelle VBR KC5000
3	2	1.003.04.014	Rondella ø35xø20x1.5	Washer ø35xø20x1.5	Unterlegscheibe ø35xø20x1.5	Arandela ø35xø20x1.5	Rondelle ø35xø20x1.5
4	1	1.011.04.049	Supporto	Support	Halter	Soporte	Support
5	1	1.012.02.005	Tappo	Cap	Deckel	Tapón	Bouchon
6	3	1.012.14.003	Tappo 3/8	Cap 3/8	Deckel 3/8	Tapn 3/8	Bouchon 3/8
7	1	1.012.14.014	Tappo G3/4	Cap G3/4	Deckel G3/4	Tapón G3/4	Bouchon G3/4
8	1	1.014.14.039	Scocca Blu KC5000-5050	Blue Cover KC5000-5050	Blauer Abdeckung KC5000-5050	Tapa Azul KC5000-5050	Copot Bleu KC5000-5050
9	1	1.014.14.040	Scocca KC5000-5050	Cover KC5000-5050	Abdeckung KC5000-5050	Tapa KC5000-5050	Copot KC5000-5050
10	1	1.015.24.006	Ghiera M2x1 VBR KC5000	Ferrule M2x1 VBR KC5000	Zwinge M2x1 VBR KC5000	Abrazadera M2x1 VBR KC5000	Embout M2x1 VBR KC5000
11	1	1.015.32.008	Ghiera G1/4"	Ferrule G1/4"	Zwinge G1/4"	Abrazadera G1/4"	Embout G1/4"
12	1	1.021.02.012	Manopla	Knob	Griff	Pomo	Poignée
13	1	1.025.12.010	Molla P115	Spring P115	Feder P115	Muelle P115	Ressort P115
14	1	1.025.22.001	Molla	Spring	Feder	Muelle	Ressort
15	1	1.036.02.001	Inserto M8	Insert M8	Einsatz M8	Inserto M8	Insert M8
16	2	1.046.04.006	Protezione "V" L360	Protection "V" L360	Schutz "V" L360	Protección "V" L360	Protection "V" L360
17	4	1.060.04.017	Distanziale ø50xø11xø7.8	Spacer ø50xø11xø7.8	Distanzstueck ø50xø11xø7.8	Distanciador ø50xø11xø7.8	Entretoise ø50xø11xø7.8
18	1	1.072.02.004	Premimolla	Spring clamp	Federdrücker	Prensamuelle	Presse-ressort
19	1	1.081.02.001	Forcella	Fork	Gabel	Horquilla	Fourche
20	2	1.085.04.009	Coprimumo ø260	Hub Cap ø260	Nabe Haus ø260	Casquillo del cubo ø260	Enjoliveur de roue ø260
21	1	1.086.04.003	Ruota girevole PK125R	Revolving wheel PK125R	Drehbares Rad PK125R	Rueda giratoria PK125R	Roue pivotante PK125R
22	2	1.086.04.009	Ruota ø260X21 SPV	Wheel ø260X21 SPV	Rad ø260X21 SPV	Rueda ø260X21 SPV	Roue ø260X21 SPV
23	1	2.006.04.039	Tubo ø13x19 40Bar L840 3/4"-3/8"	Pipe ø13x19 40Bar L840 3/4"-3/8"	Rohr ø13x19 40Bar L840 3/4"-3/8"	Tubo ø13x19 40Bar L840 3/4"-3/8"	Tuyau ø13x19 40Bar L840 3/4"-3/8"
24	1	2.006.04.044	Tubo ø19x30 20bar L1030 2x3/4"F	Pipe ø19x30 20bar L1030 2x3/4"F	Rohr ø19x30 20bar L1030 2x3/4"F	Tubo ø19x30 20bar L1030 2x3/4"F	Tuyau ø19x30 20bar L1030 2x3/4"F
25	1	2.006.24.026	Tubo ø13x19 40bar L850 2x3/8	Pipe ø13x19 40bar L850 2x3/8	Rohr ø13x19 40bar L850 2x3/8	Tubo ø13x19 40bar L850 2x3/8	Tuyau ø13x19 40bar L850 2x3/8
26	1	2.006.24.038	Tubo 3/8 400Bar R2 10m M22 - G3/8-M	Pipe 3/8 400Bar R2 10m M22 - G3/8-M	Rohr 3/8 400Bar R2 10m M22 - G3/8-M	Tubo 3/8 400Bar R2 10m M22 - G3/8-M	Tuyau 3/8 400Bar R2 10m M22 - G3/8-M
27	1	2.015.04.008	Telaio KC5000-5025-5050-6000	Frame KC5000-5025-5050-6000	Rahmen KC5000-5025-5050-6000	Estructura KC5000-5025-5050-6000	Chassis KC5000-5025-5050-6000
28	1	2.020.14.089	Cavo L150	Cable L150	Kabel L150	Cable L150	Cable L150
29	1	2.034.14.070	Motopompa + Quadro elettrico KH2030F 30-200 400V50H	Motorpump + Electric pannel KH2030F 30-200 400V50Hz	Motorpumpe + Schalttafel KH2030F 30-200 400V50Hz W2	Motobomba + Cuadro eléctrico KH2030F 30-200 400V50H	Motopompe + Cadre électrique KH2030F 30-200 400V50H
30	1	2.042.04.003	Manico	Handle	Griff	Manija	Manche
31	1	2.058.04.006	Gruppo valvola KH2030F TST	Valves Group KH2030F TST	Ventil Gruppe KH2030F TST	Groupe Vannes KH2030F TST	Grupo Válvulas KH2030F TST
32	1	3.012.02.027	Attacco rapido 3/4" PG25	Quick coupling 3/4" PG25	Schnelle Kupplung 3/4" PG25	Ataque rapido 3/4" PG25	Connexion rapide 3/4" PG25
33	1	3.032.02.005	Filtro "Y" 3/4G F\F 45 MESH	Filter "Y" 3/4G F\F 45 MESH	Filter "Y" 3/4G F\F 45 MESH	Filtro "Y" 3/4G F\F 45 MESH	Filtre "Y" 3/4G F\F 45 MESH
34	1	3.045.04.008	Kit accessori KH2030F	Accessories kit KH2030F	Kit Zubehör KH2030F	Kit accesorios KH2030F	Kit accessoires KH2030F
35	4	4.002.14.021	Vite M8x14 ISO7380	Screw M8x14 ISO7380	Schrauben M8x14 ISO7380	Tornillo M8x14 ISO7380	Vis M8x14 ISO7380
36	3	4.002.17.004	Vite M6x16 ISO 7380	Screw M6x16 ISO 7380	Schrauben M6x16 ISO 7380	Tornillo M6x16 ISO 7380	Vis M6x16 ISO 7380
37	4	4.002.44.013	Vite M10x45 UNI 5737-65	Screw M10x45 UNI 5737-65	Schrauben M10x45 UNI 5737-65	Tornillo M10x45 UNI 5737-65	Vis M10x45 UNI 5737-65
38	4	4.002.44.017	Vite M8x75 UNI5737	Screw M8x75 UNI5737	Schrauben M8x75 UNI5737	Tornillo M8x75 UNI5737	Vis M8x75 UNI5737
39	1	4.002.94.015	Vite autofilettante 3.9x9.5	Self-tapping Screw 3.9x9.5	Selbschneidendeschraube 3.9x9.5	Tornillo autoblocante 3.9x9.5	Vis autofiletant 3.9x9.5
40	1	4.005.22.003	OR 2015	O-ring 2015	O-Ring 2015	OR 2015	Joint torique 2015
41	1	4.008.02.002	Rondella ø4.3xø8x0.5 (OT)	Washer ø4.3xø8x0.5 (OT)	Unterlegscheibe ø4.3xø8x0.5 (OT)	Arandela M4.3xø8x0.5 (OT)	Rondelle ø4.3xø8x0.5 (OT)
42	8	4.008.04.002	Rondella M8 UNI6592	Washer M8 UNI6592	Unterlegscheibe M8 UNI6592	Arandela M8 UNI6592	Rondelle M8 UNI6592
43	4	4.008.04.004	Rondella M10 UNI6592	Washer M10 UNI6592	Unterlegscheibe M10 UNI6592	Arandela M10 UNI6592	Rondelle M10 UNI6592
44	1	4.008.54.001	Rondella di sicurezza UNI8842 M4	Safety washer UNI8842 M4	Sicherheits Scheibe UNI8842 M4	Arandela de seguridad UNI8842 M4	Rondelle de sûreté UNI8842 M4
45	4	4.008.54.003	Rondella M10 UNI1751-A	Washer M10 UNI1751-A	Unterlegscheibe M10 UNI1751-A	Arandela M10 UNI1751-A	Rondelle M10 UNI1751-A
46	3	4.008.67.001	Rondella ø6xø16x3 UNI6594	Washer ø6xø16x3 UNI6594	Unterlegscheibe ø6xø16x3 UNI6594	Arandela ø6xø16x3 UNI6594	Rondelle ø6xø16x3 UNI6594
47	5	4.009.12.001	Dado M8 UNI7474	Nut M8 UNI7474	Mutter M8 UNI7474	Dado M8 UNI7474	Ecrou M8 UNI7474
48	1	4.026.02.002	Pressacavo PG16	Cable clamping PG16	Kabelklemme PG16	Prensacables PG16	Serre-câble PG16
49	1	4.027.02.080	Ugello SA1\4MEG-1510	Nozzle SA1\4MEG-1510	Duse SA1\4MEG-1510	Boquilla SA1\4MEG-1510	Buse SA1\4MEG-1510
50	2	4.044.04.004	Copiglia ø3.2x36 UNI1336	Spit-pin ø3.2x36 UNI1336	Splint ø3.2x36 UNI1336	Chaveta ø3.2x36 UNI1336	Goupille ø3.2x36 UNI1336
51	4	4.047.04.001	Inserto M10	Insert M10	Einsatz M10	Inserto M10	Insert M10
52	6	4.070.04.001	Guarnizione G3/8	Gasket G3/8	Dichtung G3/8	Guarnición G3/8	Garniture G3/8
53	2	4.070.04.003	Guarnizione 3/4	Gasket G3/4	Dichtung G3/4	Guarnición G3/4	Garniture G3/4

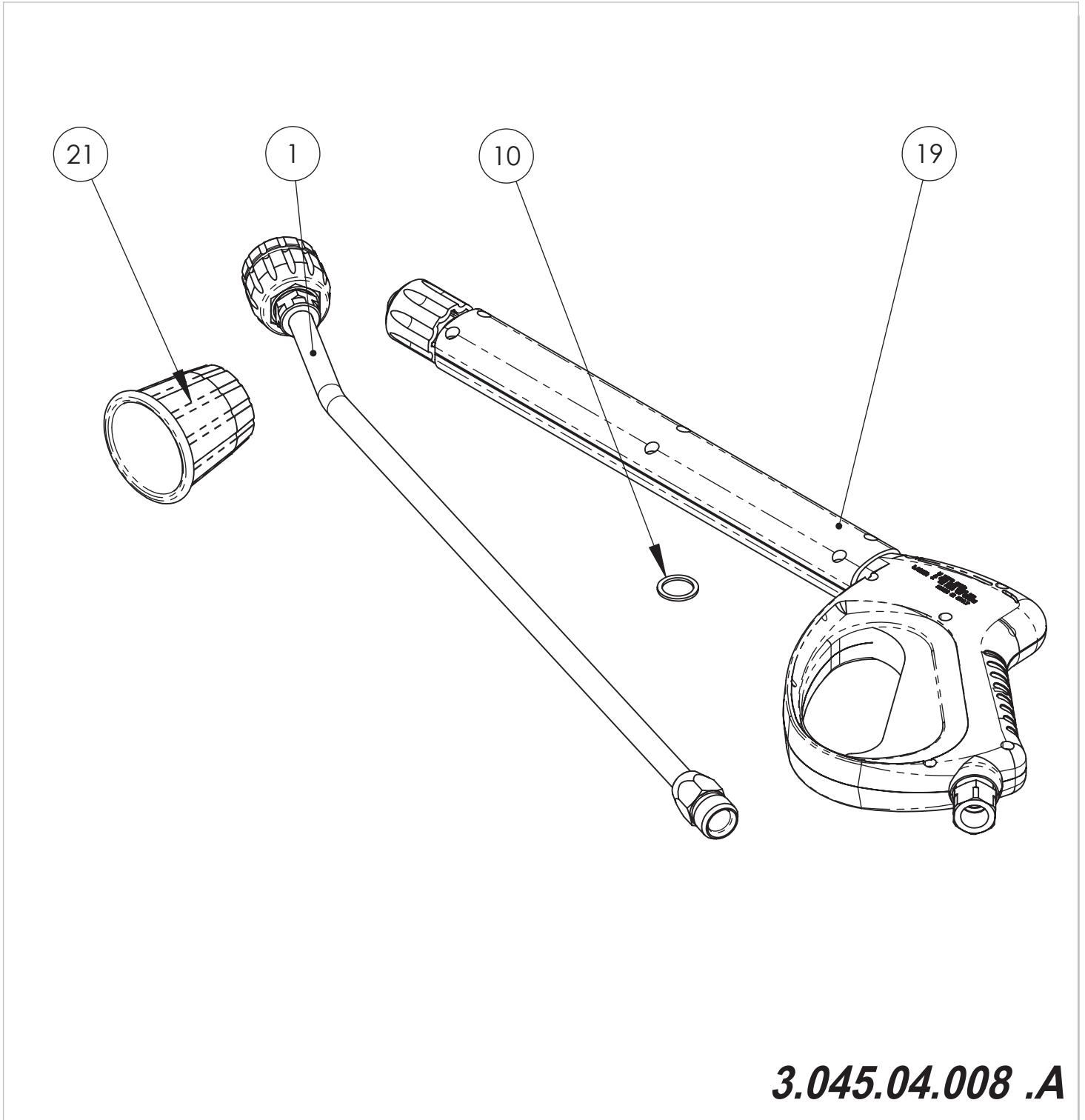

Pos.	Q.tà	Cod.	ITALIANO	INGLESE	TEDESCO	SPAGNOLO	FRANCESE
1	1	1.046.02.015	Protezione	Protection	Scutzt	Protección	Protection
2	1	3.020.22.021	Prolunga + Testina Regolabile L=500	Extension and Adjustable head L=500	Verlängerung und Einstellbarer Kopf L=500	Prolongacion + Cabeza regulable L=500	Rallonge + Tête réglable L=500
3	1	3.021.22.003	Pistola + Impugnatura "LASER" G3/8"F Sweevel	Trigger Gun + Grip "LASER" G3/8"F Sweevel	Pistole + Handgriff "LASER" G3/8"F Sweevel	Pistola + Empunadura "LASER" G3/8"F Sweevel	Pistolet + Branche "LASER" G3/8"F Sweevel
4	1	4.008.12.001	Rondella Rame G3/8	Copper washer G3/8	Kupferunterlegsscheibe G3/8	Arandela de cobre G3/8	Rondelle cuivre G3/8

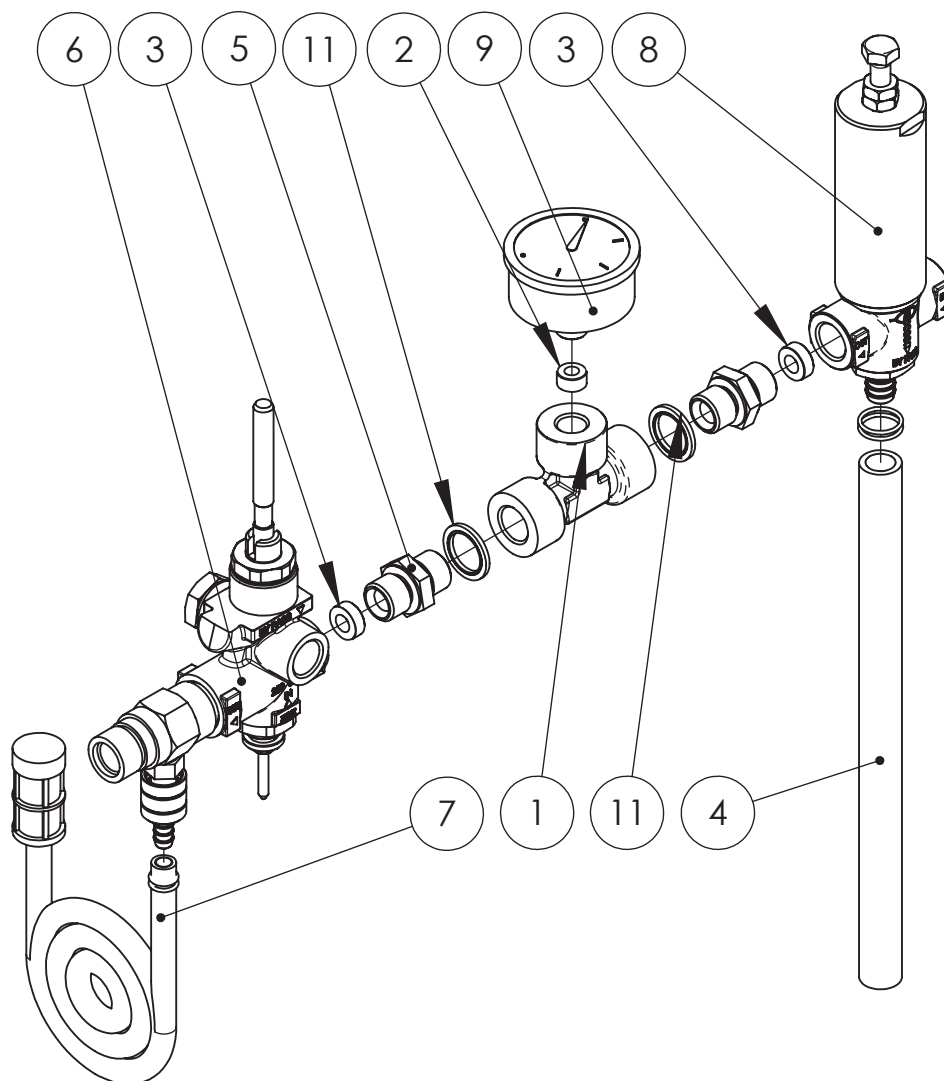

2.058.04.006 .C

Pos.	Q.ta	Cod.	ITALIANO	INGLESE	TEDESCO	SPAGNOLO	FRANCESE
1	1	1.001.24.008	Raccordo T 3/8GFF 1/4F	Connection T 3/8GFF 1/4F	Leiste T 3/8GFF 1/4F	Filete T 3/8GFF 1/4F	Filet T 3/8GFF 1/4F
2	1	1.006.11.007	Guarnizione ø6xø11.8x6	Gasket ø6xø11.8x6	Dichtung ø6xø11.8x6	Guarnición ø6xø11.8x6	Garniture ø6xø11.8x6
3	2	1.006.22.001	Guarnizione ø14.7xø7.7x5.3	Gasket ø14.7xø7.7x5.3	Dichtung ø14.7xø7.7x5.3	Guarnición ø14.7xø7.7x5.3	Garniture ø14.7xø7.7x5.3
4	1	1.044.44.017	Tubo VITREX ø11x16x250	Pipe VITREX ø11x16x250	Rohr VITREX ø11x16x250	Tubo VITREX ø11x16x250	Tuyau VITREX ø11x16x250
5	2	1.096.04.001	Nipples	Nipples	Nipples	Nipples	Nipples
6	1	2.003.34.016	Valvola di regolazione Pressione KH2030F TST	Pressure unloader valve KH2030F TST	Druckregelventile KH2030F TST	Válvula reguladores de presión KH2030F TST	Valve regulateur de pression KH2030F TST
7	1	2.074.04.044	Tubo aspirazione MH	Suction pipe MH	Saugrohr MH	Tubo de aspiración MH	Tube d'aspiration MH
8	1	3.003.22.006	Valvola di sicurezza 250Bar G3/8-FF	Safety pressure valve 250Bar G3/8-FF	Max druck Einstellungsventile 250Bar G3/8-FF	Valvula de seguridad 250Bar G3/8-FF	Souppape de pression maximal 250Bar G3/8-FF
9	1	4.020.14.002	Manometro ø50 400B G1/4	Pressure gauge ø50 400B G1/4	Druckmesser ø50 400B G1/4	Manómetro ø50 400B G1/4	Manomètre ø50 400B G1/4
10	1	4.022.04.009	Fascetta AUTOSERRANTI ø16	Clamp AUTOSERRANTI ø16	Klemme AUTOSERRANTI ø16	Faja AUTOSERRANTI ø16	Petit bande AUTOSERRANTI ø16
11	2	4.070.04.001	Guarnizione G3/8	Gasket G3/8	Dichtung G3/8	Guarnición G3/8	Garniture G3/8

Valvola di regolazione Pressione KH2030F

Pressure unloader valve KH2030F

Druckregelventile KH2030F



Valve regulateur de presion KH2030F

Válvula reguladores de presion KH2030F

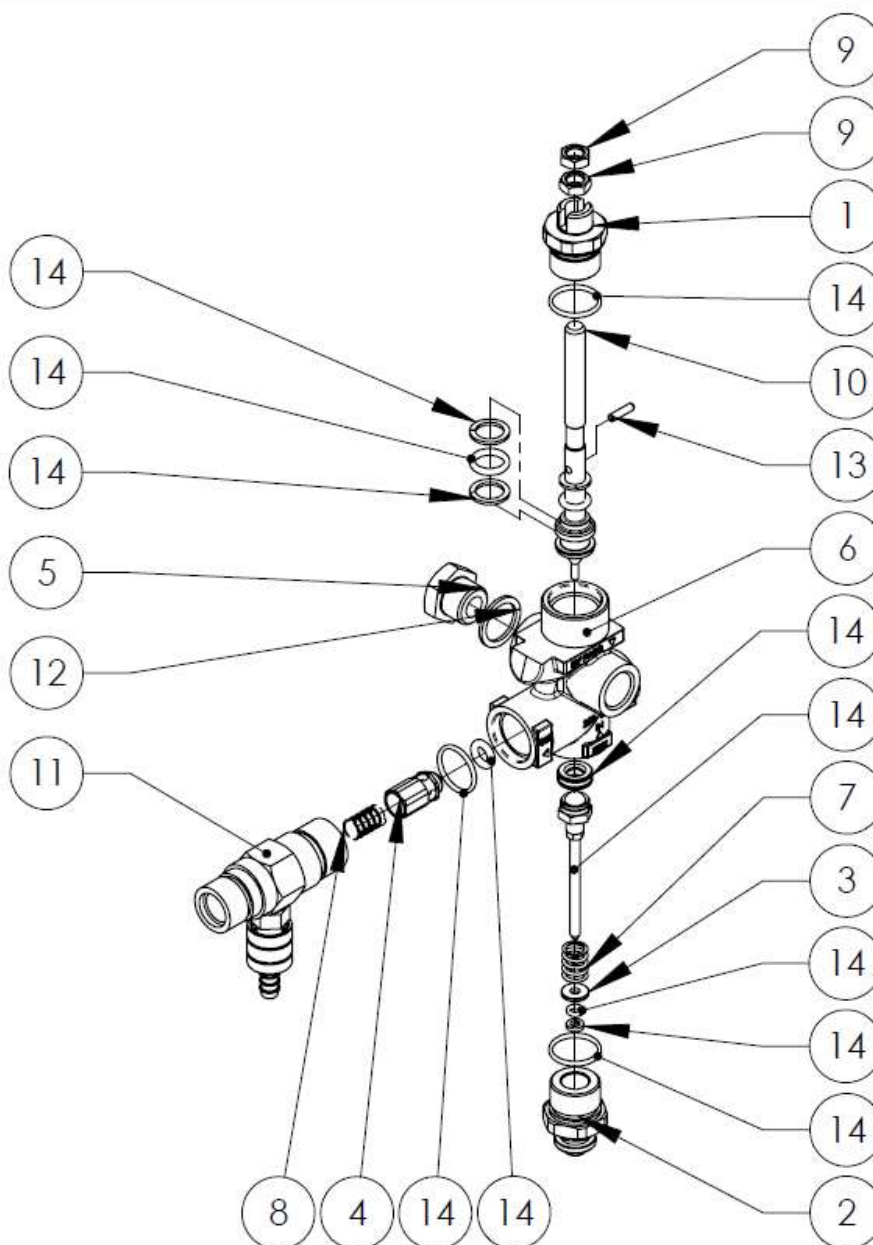

2.003.34.016 .A

Pos.	Q.tà	Cod.	ITALIANO	INGLESE	TEDESCO	SPAGNOLO	FRANCESE
1	1	1.001.02.002	Raccordo M20x3\8	Connection M20x3\8	Leiste M20x3\8	Filete M20x3\8	Filet M20x3\8
2	1	1.001.02.024	Raccordo	Connection	Leiste	Filete	Filet
3	1	1.003.02.004	Rondella ø4x11x1.5	Washer ø4x11x1.5	Unterlegscheibe ø4x11x1.5	Arandela ø4x11x1.5	Rondelle ø4x11x1.5
4	1	1.007.02.001	Otturatore	Shutter	Obturador	Verschluss	Obturator
5	1	1.012.12.001	Tappo G3/8"	Cap G3/8"	Deckel G3/8"	Tapón G3/8"	Bouchon G3/8"
6	1	1.020.22.020	Corpo	Body	Körper	Cuerpo	Corps
7	1	1.025.12.002	Molla 15x1.4	Spring 15x1.4	Feder 15x1.4	Muelle 15x1.4	Ressort 15x1.4
8	1	1.025.12.003	Molla ø0.7xøe9xh21	Spring ø0.7xøe9xh21	Feder ø0.7xøe9xh21	Muelle ø0.7xøe9xh21	Ressort ø0.7xøe9xh21
9	2	1.035.02.001	Dado M8	Nut M8	Mutter M8	Dado M8	Ecrou M8
10	1	1.037.02.001	Stelo VRB	Stem VRB	Spindel VRB	Vastago VRB	Tige VRB
11	1	3.016.12.016	* Iniettore M22x1,5 M20x1.5 MM REG 2.5	Injector M22x1,5 M20x1.5 MM REG 2.5	Injector M22x1,5 M20x1.5 MM REG 2.5	Injector M22x1,5 M20x1.5 MM REG 2.5	Injecteur M22x1,5 M20x1.5 MM REG 2.5
12	1	4.008.12.001	Rondella Rame G3/8	Copper washer G3/8	Kupferunterlegsscheibe e G3/8	Arandela de cobre G3/8	Rondelle cuivre G3/8
13	1	4.011.12.001	Spina	Plug	Stecker	Enchufe	Prise
14	1	9.003.02.007	Kit Tenute	Spare seals kit	Kit Dichtungen	Kit cierres	Kit joints détanchéité

*OPTIONAL

Valvola di sicurezza 250Bar G3/8-FF

Safety pressure valve 250Bar G3/8-FF

Max druck Einstellungsventile 250Bar G3/8-FF

KRÜGER
Technology S.L.

Soupape de pression maximal 250Bar G3/8-FF

Valvula de seguridad 250Bar G3/8-FF

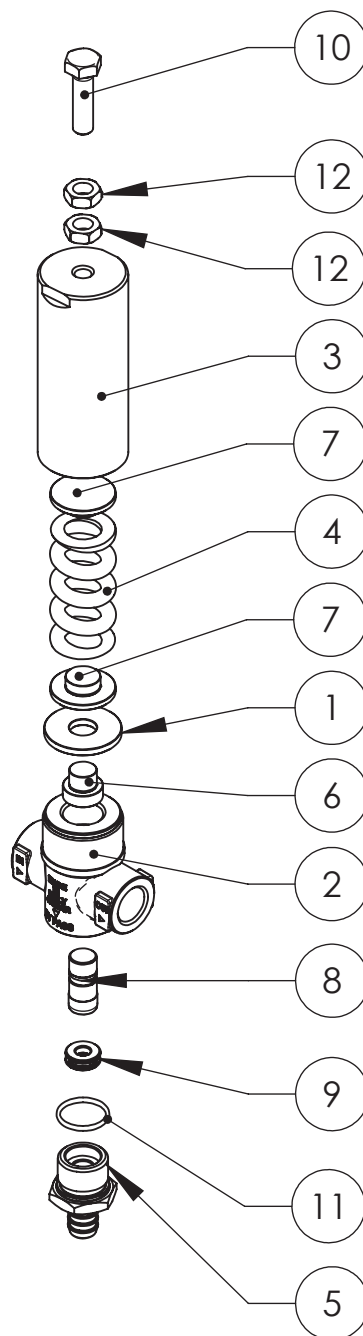

3.003.22.006 .B

Pos.	Q.tà	Cod.	ITALIANO	INGLESE	TEDESCO	SPAGNOLO	FRANCESE
1	1	1.003.04.018	Rondella	Washer	Unterlegscheibe	Arandela	Rondelle
2	1	1.020.22.022	Corpo	Body	Körper	Cuerpo	Corps
3	1	1.020.22.023	Corpo VS 250BAR	Body VS 250BAR	Körper VS 250BAR	Cuerpo VS 250BAR	Corps VS 250BAR
4	1	1.025.22.001	Molla	Spring	Feder	Muelle	Ressort
5	1	1.049.02.007	Portagomma ø12xM20x1.5 M	Hose fitting ø12xM20x1.5 M	Schlauchhalter ø12xM20x1.5 M	Portamanguera ø12xM20x1.5 M	Raccord pour tuyau ø12xM20x1.5 M
6	1	1.071.02.010	Pistone	Piston	Kolben	Pistón	Piston
7	2	1.072.02.016	Premimolla	Spring clamp	Federdrücker	Prensamuelle	Presse-ressort
8	1	2.002.02.004	Otturatore	Shutter	Obturador	Verschluss	Obturateur
9	1	2.051.02.001	Seeger	Seeger	Seeger	Seeger	Seeger
10	1	4.002.42.003	Vite M8x30 UNI5739	Screw M8x30 UNI5739	Schrauben M8x30 UNI5739	Tornillo M8x30 UNI5739	Vis M8x30 UNI5739
11	1	4.005.21.011	OR	O-ring	O-Ring	OR	Joint torique
12	2	4.009.04.003	Dado M8 UNI5589	Nut M8 UNI5589	Mutter M8 UNI5589	Dado M8 UNI5589	Ecrou M8 UNI5589

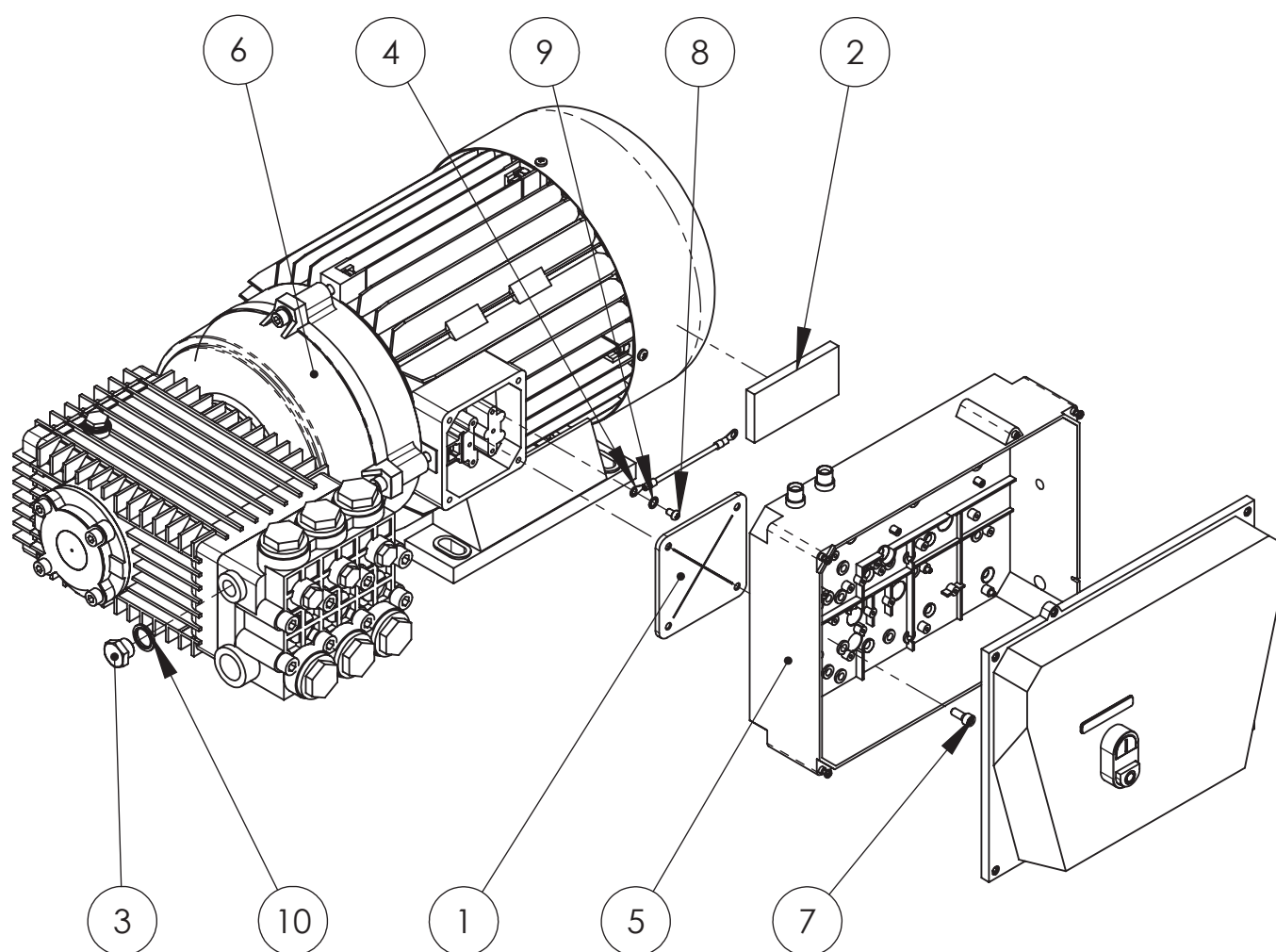

2.034.14.070 .A

Pos.	Q.ta	Cod.	ITALIANO	INGLESE	TEDESCO	SPAGNOLO	FRANCESE
1	1	1.006.12.011	Guarnizione U IP44	Gasket U IP44	Dichtung U IP44	Guarnición U IP44	Garniture U IP44
2	1	1.006.14.011	Guarnizione 50x10x100	Gasket 50x10x100	Dichtung 50x10x100	Guarnición 50x10x100	Garniture 50x10x100
3	1	1.012.12.001	Tappo G3/8"	Cap G3/8"	Deckel G3/8"	Tapón G3/8"	Bouchon G3/8"
4	1	2.020.14.045	Cavo elettrico 2.5 GV L=280	Power cable 2.5 GV L=280	Energie kabel 2.5 GV L=280	Cable eléctrico 2.5 GV L=280	Cable électrique 2.5 GV L=280
5	1	2.031.04.101	Quadro elettrico KC5050 400V3F 50Hz kW 11 TST	Electric pannel KC5050 400V3F 50Hz kW 11 TST	Schalttafel KC5050 400V3F 50Hz kW 11 TST	Cuadro eléctrico KC5050 400V3F 50Hz kW 11 TST	Cadre électrique KC5050 400V3F 50Hz kW 11 TST
6	1	3.006.12.086	Motopompa MEC132B3BL 190Bar 30L/min 11Kw50Hz+W2030	Motorpump MEC132B3BL 190Bar 30L/min 11Kw50Hz+W2030	Motorpumpe MEC132B3BL 190Bar 30L/min 11Kw50Hz+W203	Motobomba MEC132B3BL 190Bar 30L/min 11Kw50Hz+W2030	Motopompe MEC132B3BL 190Bar 30L/min 11Kw50Hz+W2030
7	4	4.002.12.013	Vite M6x16 UNI5931	Screw M6x16 UNI5931	Schrauben M6x16 UNI5931	Tornillo M6x16 UNI5931	Vis M6x16 UNI5931
8	1	4.002.74.003	Vite M5x8 UNI7687	Screw M5x8 UNI7687	Schrauben M5x8 UNI7687	Tornillo M5x8 UNI7687	Vis M5x8 UNI7687
9	1	4.008.52.001	Rondella di sicurezza M6	Safety washer M6	Sicherheits Scheibe M6	Arandela de seguridad M6	Rondelle de sûreté M6
10	1	4.070.04.001	Guarnizione G3/8	Gasket G3/8	Dichtung G3/8	Guarnición G3/8	GarnitureG3/8

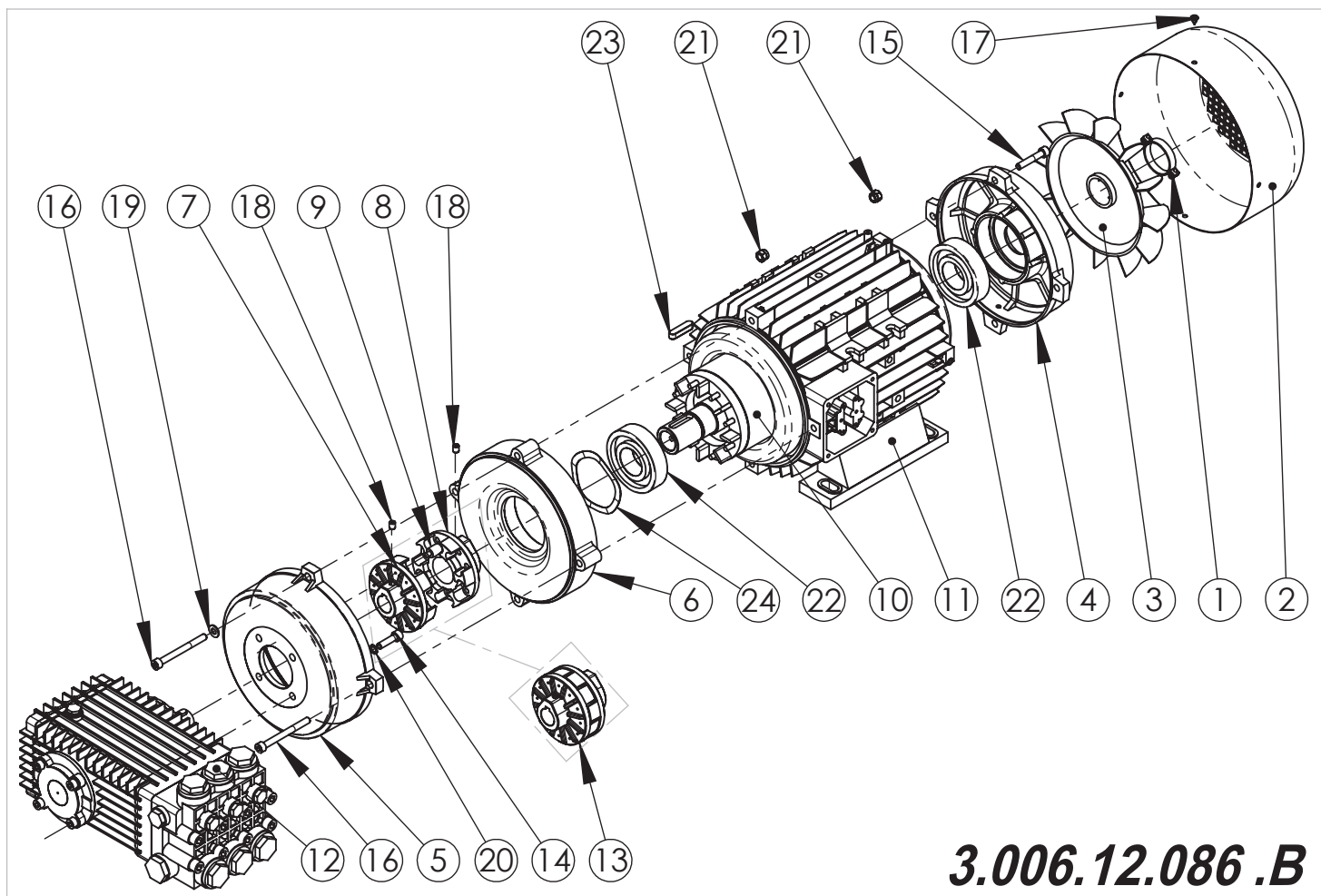

3.006.12.086 .B

Pos.	Q.tà	Cod.	ITALIANO	INGLESE	TEDESCO	SPAGNOLO	FRANCESE
1	1	1.045.02.007	Fascetta Ventola MEC 132	Clamp Impeller MEC 132	Klemme Antreiber MEC 132	Faja Impedor MEC 132	Petit bande Roue à aubes MEC 132
2	1	1.046.02.017	Protezione ventola MEC 132	Fan protection MEC 132	Antreiberschutz MEC 132	Protección del ventilador MEC 132	Protection du ventilateur MEC 132
3	1	1.073.02.005	Ventola M132M	Impeller M132M	Antreiber M132M	Impedor M132M	Roue à aubes M132M
4	1	1.074.02.012	Flangia posteriore MEC 132	back flange MEC 132	Rückseitiger Flansch MEC 132	Reborde trasero MEC 132	Bride arrier MEC 132
5	1	1.074.02.031	Flangia anteriore MEC 132	Front flange MEC 132	Forderer Flansch MEC 132	Reborde delantero MEC 132	Bride avant MEC 132
6	1	1.074.02.032	Flangia lato pompa MEC 132	Pump side flange MEC 132	Pumpe seitlicher Flansch MEC 132	Reborde lateral de la bomba MEC 132	Bride lateral de pompe MEC 132
7	1	1.131.02.009	Mozzo MEC132 ø24	Hub MEC132 ø24	Nabe MEC132 ø24	Cubo MEC132 ø24	Moyeu MEC132 ø24
8	1	1.131.02.010	Mozzo G132 ø38	Hub G132 ø38	Nabe G132 ø38	Cubo G132 ø38	Moyeu G132 ø38
9	12	1.157.02.001	Ammortizzatore	Cushion	Dämpfer	Amortiguador	Amortisseur
10	1	2.014.02.043	Albero Premontato	Preassembled shaft	Vormontierung welle	Preensamblado eje	Préassemblé arbre
11	1	2.017.02.026	Carter Montato M132M BL 4P50Hz11kW	Assembled Guard M132M BL 4P50Hz11kW	Montiertes Gehäuse M132M BL 4P50Hz11kW	Ensamblado Carter M132M BL 4P50Hz11kW	Carter assemblé M132M BL 4P50Hz11kW
12	1	3.015.12.034	Pompa W2030 DX	Pump W2030 DX	Pump W2030 DX	Bomba W2030 DX	Pompe W2030 DX
13	1	3.055.02.001	Giunto ø24/ø38	Coupling ø24/ø38	Kupplung ø24/ø38	Acoplamiento ø24/ø38	Accouplement ø24/ø38
14	4	4.002.12.004	Vite M8x30 UNI5931	Screw M8x30 UNI5931	Schrauben M8x30 UNI5931	Tornillo M8x30 UNI5931	Vis M8x30 UNI5931
15	4	4.002.12.018	Vite M8x45 UNI5931	Screw M8x45 UNI5931	Schrauben M8x45 UNI5931	Tornillo M8x45 UNI5931	Vis M8x45 UNI5931
16	4	4.002.12.021	Vite M8x85 UNI5931	Screw M8x85 UNI5931	Schrauben M8x85 UNI5931	Tornillo M8x85 UNI5931	Vis M8x85 UNI5931
17	4	4.002.94.010	Vite autofilettante UNI6954 4.8x9.5	Self-tapping Screw UNI6954 4.8x9.5	Selbschneidendeschraube UNI6954 4.8x9.5	Tornillo autoblocante UNI6954 4.8x9.5	Vis autofiletant UNI6954 4.8x9.5
18	2	4.004.42.005	Grano M8x10 UNI 5929	Grub screw M8x10 UNI 5929	Duebel M8x10 UNI 5929	Grano M8x10 UNI 5929	Grain M8x10 UNI 5929
19	1	4.008.04.002	Rondella M8 UNI6592	Washer M8 UNI6592	Unterlegscheibe M8 UNI6592	Arandela M8 UNI6592	Rondelle M8 UNI6592
20	4	4.008.52.002	Rondella di sicurezza UNI8842 M8	Safety washer UNI8842 M8	Sicherheits Scheibe UNI8842 M8	Arandela de seguridad UNI8842 M8	Rondelle de sûreté UNI8842 M8
21	6	4.009.14.001	Dado M8 UNI7473	Nut M8 UNI7473	Mutter M8 UNI7473	Dado M8 UNI7473	Ecrou M8 UNI7473
22	2	4.016.02.007	Cuscinetto SKF6308 ZZ C3 40x90x23	Bearing SKF6308 ZZ C3 40x90x23	Kugellager SKF6308 ZZ C3 40x90x23	Rodamiento SKF6308 ZZ C3 40x90x23	Roulement SKF6308 ZZ C3 40x90x23
23	1	4.021.02.003	Chiaveffia 10x8x40 UNI6604-A	Key 10x8x40 UNI6604-A	Keil 10x8x40 UNI6604-A	Chaveffia 10x8x40 UNI6604-A	Clavette 10x8x40 UNI6604-A
24	1	4.049.12.004	Anello di compensazione B90 6308	Compression ring B90 6308	Kompressionring B90 6308	Anillo de compresión B90 6308	Anneau de compression B90 6308

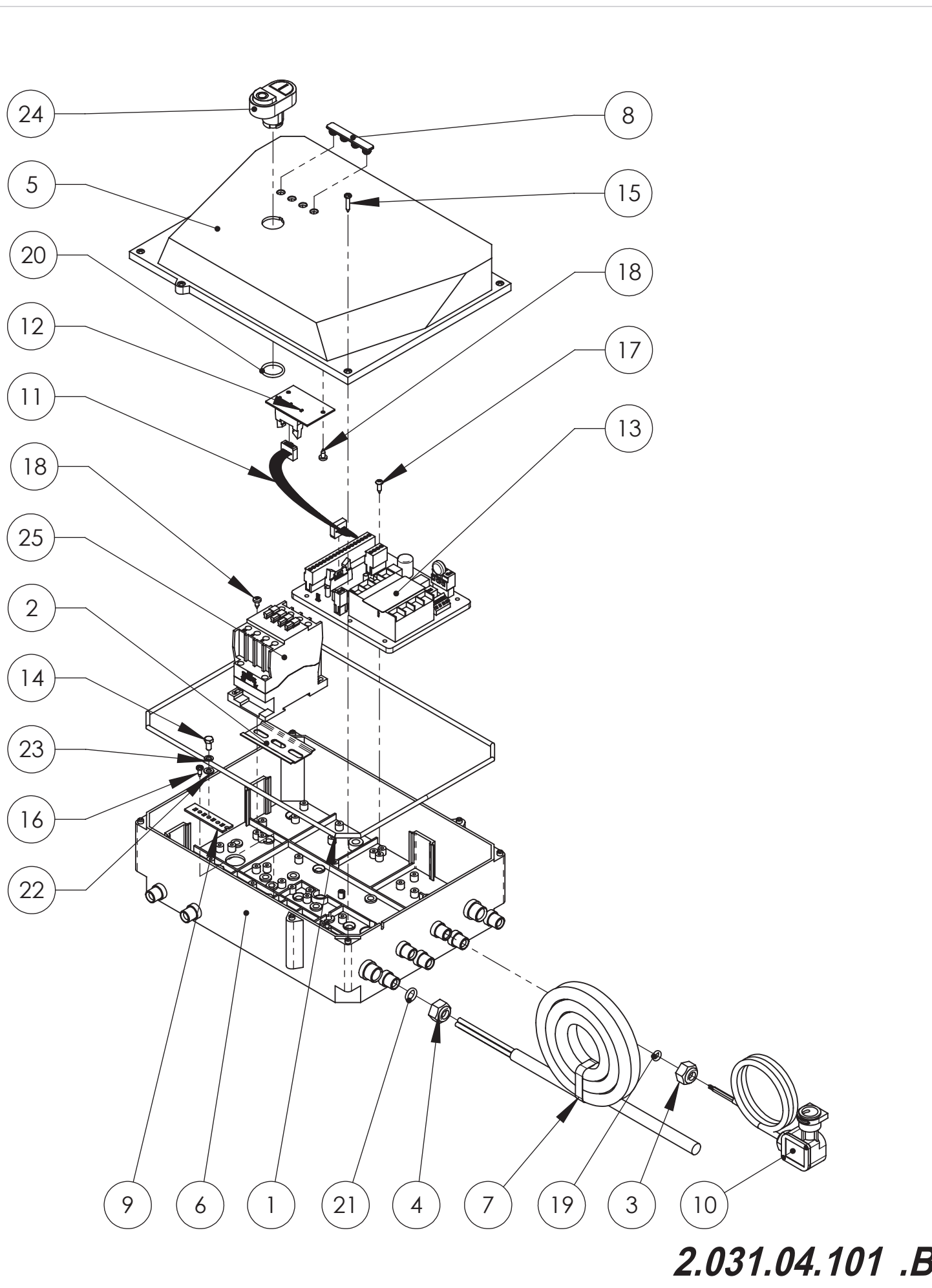

2.031.04.101 .B

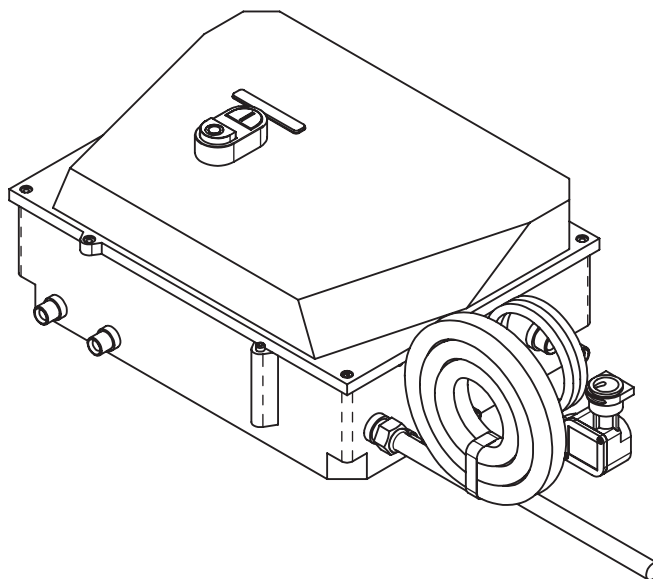

2.031.04.101.B

Pos.	Q.tà	Cod.	ITALIANO	INGLESE	TEDESCO	SPAGNOLO	FRANCESE
1	1	1.006.14.004	Guarnizione ø4x1020	Gasket ø4x1020	Dichtung ø4x1020	Guarnición ø4x1020	Garniture ø4x1020
2	1	1.011.04.033	Supporto OMEGA L73	Support OMEGA L73	Halter OMEGA L73	Soporte OMEGA L73	Support OMEGA L73
3	1	1.015.32.008	Ghiera G1/4"	Ferrule G1/4"	Zwinge G1/4"	Abrazadera G1/4"	Embout G1/4"
4	1	1.015.32.011	Ghiera	Ferrule	Zwinge	Abrazadera	Embout
5	1	1.054.04.015	Coperchio K5000	Cover K5000	Deckel K5000	Tapa K5000	Couvercle K5000
6	1	1.078.04.022	Scatola elettrica 310x230x82 KC5000-5050	Electric case 310x230x82 KC5000-5050	Elektrokasten 310x230x82 KC5000-5050	Caja eléctrica 310x230x82 KC5000-5050	boîte électrique 310x230x82 KC5000-5050
7	1	1.088.04.044	Cavo elettrico	Power cable	Energie kabel	Cable electrico	Cable électrique
8	1	1.102.04.002	Vetrino	Glass	Glass	Vidrio	Vèrre
9	1	1.128.04.002	Morsetto L55	Clamp L55	Klemme L55	Prensita de sujeción L55	Colier de serrage L55
10	1	2.008.02.002	Pressostato S2	pressure gauge S2	Druckschalter S2	Presostato S2	Pressostat S2
11	1	2.020.32.002	Cavo L380 BL	Cable L380 BL	Kabel L380 BL	Cable L380 BL	Cable L380 BL
12	1	3.024.02.019	Scheda MCC10/15	Board MCC10/15	Karte MCC10/15	Tarjeta MCC10/15	Carte MCC10/15
13	1	3.024.02.023	Scheda elettronica MCC15-M	Electronic Board MCC15-M	ElektronischeKarte MCC15-M	Tarjeta electrónico MCC15-M	Carte électronique MCC15-M
14	2	4.002.44.011	Vite M5x10 UNI5739	Screw M5x10 UNI5739	Schrauben M5x10 UNI5739	Tornillo M5x10 UNI5739	Vis M5x10 UNI5739
15	4	4.002.92.001	Vite autofilettante 3.5x19	Self-tapping Screw 3.5x19	Selbschneidendeschra ube 3.5x19	Tornillo autoblocante 3.5x19	Vis autofiletant 3.5x19
16	1	4.002.92.003	Vite autofilettante 3.5x10 AB	Self-tapping Screw 3.5x10 AB	Selbschneidendeschra ube 3.5x10 AB	Tornillo autoblocante 3.5x10 AB	Vis autofiletant 3.5x10 AB
17	4	4.002.94.005	Vite autofilettante 3.9x13	Self-tapping Screw 3.9x13	Gewindeschneidschra ube 3.9x13	Tornillo Self-tapping 3.9x13	Vies Autofilettante 3.9x13
18	4	4.002.94.015	Vite autofilettante 3.9x9.5	Self-tapping Screw 3.9x9.5	Selbschneidendeschra ube 3.9x9.5	Tornillo autoblocante 3.9x9.5	Vis autofiletant 3.9x9.5
19	1	4.005.22.009	Guarnizione OR 3024 6.02x2.62	Gasket OR 3024 6.02x2.62	Dichtung OR 3024 6.02x2.62	Guarnición OR 3024 6.02x2.62	Garniture OR 3024 6.02x2.62
20	1	4.005.22.025	OR 3075	O-ring 3075	O-Ring 3075	OR 3075	Joint torique 3075
21	1	4.005.24.001	OR 112	O-ring 112	O-Ring 112	OR 112	Joint torique 112
22	2	4.008.04.005	Rondella M5 UNI6592	Washer M5 UNI6592	Unterlegsscheibe M5 UNI6592	Arandela M5 UNI6592	Rondelle M5 UNI6592
23	2	4.008.54.002	Rondella di sicurezza UNI8842 M5	Safety washer UNI8842 M5	Sicherheits Scheibe UNI8842 M5	Arandela de seguridad UNI8842 M5	Rondelle de sûreté UNI8842 M5
24	1	4.018.04.008	Interruttore ø22	Switch ø22	Schalter ø22	Interruptor ø22	Interrupteur ø22
25	1	4.042.04.019	Teleruttore	Remote control switch	Fernschalter	Telerruptor	Telerupteur