

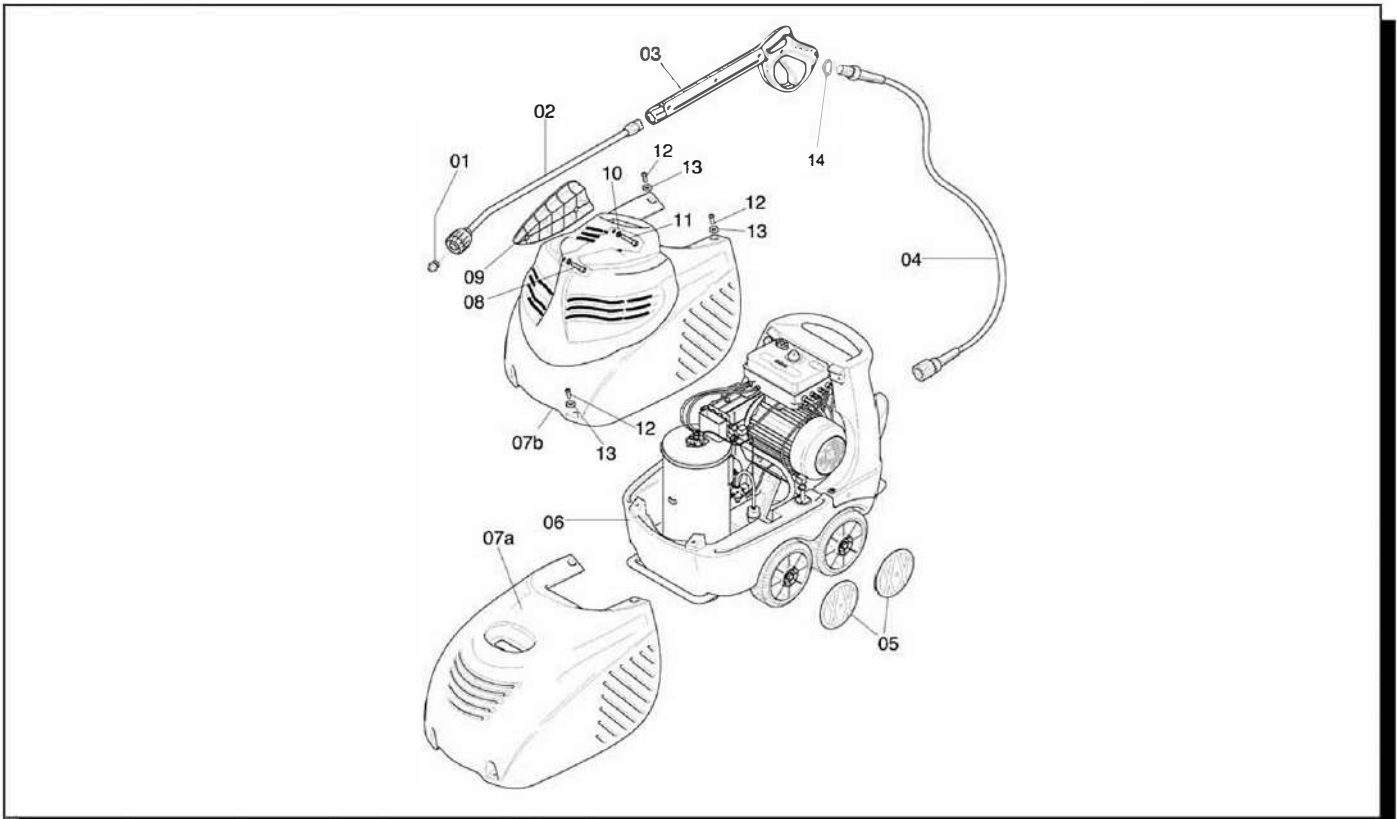

DESPIECE TÉCNICO
HIDROLIMPIADORA AGUA CALIENTE
KH20020CSP



KHZ00ZOCSP KHZSOZOCSP KH2003OCSP



Pos.	Cod.	Descrizione	Description	Descripción	N°
01a	4.027.04.044	Ugello W5000	Nozzle W5000	Tobera W5000	1
01b	4.027.02.045	Ugello W5025	Nozzle W5025	Tobera W5025	1
01c	4.027.02.077	Ugello W5050	Nozzle W5050	Tobera W5050	1
01d	4.027.02.080	Ugello W6000	Nozzle W6000	Tobera W6000	1
02	3.022.12.034	Lancia	Lance	Lanza	1
03	3.021.22.003	Pistola	Trigger gun	Pistola	1
04	2.006.24.038	Tubo	Tube	Tubo	1
05	1.085.04.011	Coprismozzo nero	Black hub-cap	Tapacubos negro	4
06a	2.049.24.041	Premontato idro W5000 "Hawk"	Preassembled idro W5000 "Hawk"	Preensamblado idro W5000 "Hawk"	1
06b	2.049.24.048	Premontato idro W5000 "Interpump"	Preassembled idro W5000 "Interpump"	Preensamblado idro W5000 "Interpump"	1
06c	2.049.24.047	Premontato idro W5025	Preassembled idro W5025	Preensamblado idro W5025	1
06d	2.049.24.057	Premontato idro W5050 "Hawk"	Preassembled idro W5050 "Hawk"	Preensamblado idro W5050 "Hawk"	1
06e	2.049.24.058	Premontato idro W5050 "Interpump"	Preassembled idro W5050 "Interpump"	Preensamblado idro W5050 "Interpump"	1
06f	2.049.24.068	Premontato idro W6000	Preassembled idro W6000	Preensamblado idro W6000	1
07a	1.014.14.025	Scocca blu W5000/W5025/W5050	Blue cover W5000/W5025/W5050	Bastidor azul W5000/W5025/W5050	1
07b	1.014.14.027	Scocca rossa W5000/W5025/W5050	Red cover W5000/W5025/W5050	Bastidor rojo W5000/W5025/W5050	1
07c	1.014.14.028	Scocca gialla W5000/W5025/W5050	Yellow cover W5000/W5025/W5050	Bastidor amarillo W5000/W5025/W5050	1
07d	1.014.14.047	Scocca blu W6000	Blue cover W6000	Bastidor azul W6000	1
07e	1.014.14.050	Scocca rossa W6000	Redcover W6000	Bastidor rojo W6000	1
07f	1.014.14.051	Scocca gialla W6000	Yellow cover W6000	Bastidor amarillo W6000	1
08	4.002.12.007	Vite M6x35	M6x35 screw	Tornillo M6x35	1
09	1.011.04.030	Supporto porta lancia	Washing gun holder suport	Soporte porta-pistola de lavado	1
10	4.008.24.001	Rondella	Washer	Arandela	2
11	4.002.12.008	Vite M6x25	M6x25 screw	Tornillo M6x25	1
12	4.002.14.021	Vite M8x14	M8x14 screw	Tornillo M8x14	4
13	1.003.04.012	Rondella PVC	PVC washer	Arandela PVC	4
14	4.008.12.001	Rondella rame 3/8"G	3/8"G copper washer	Arandela 3/8"G	1

PROLUNGA – EXTENSION – ALARGADOR

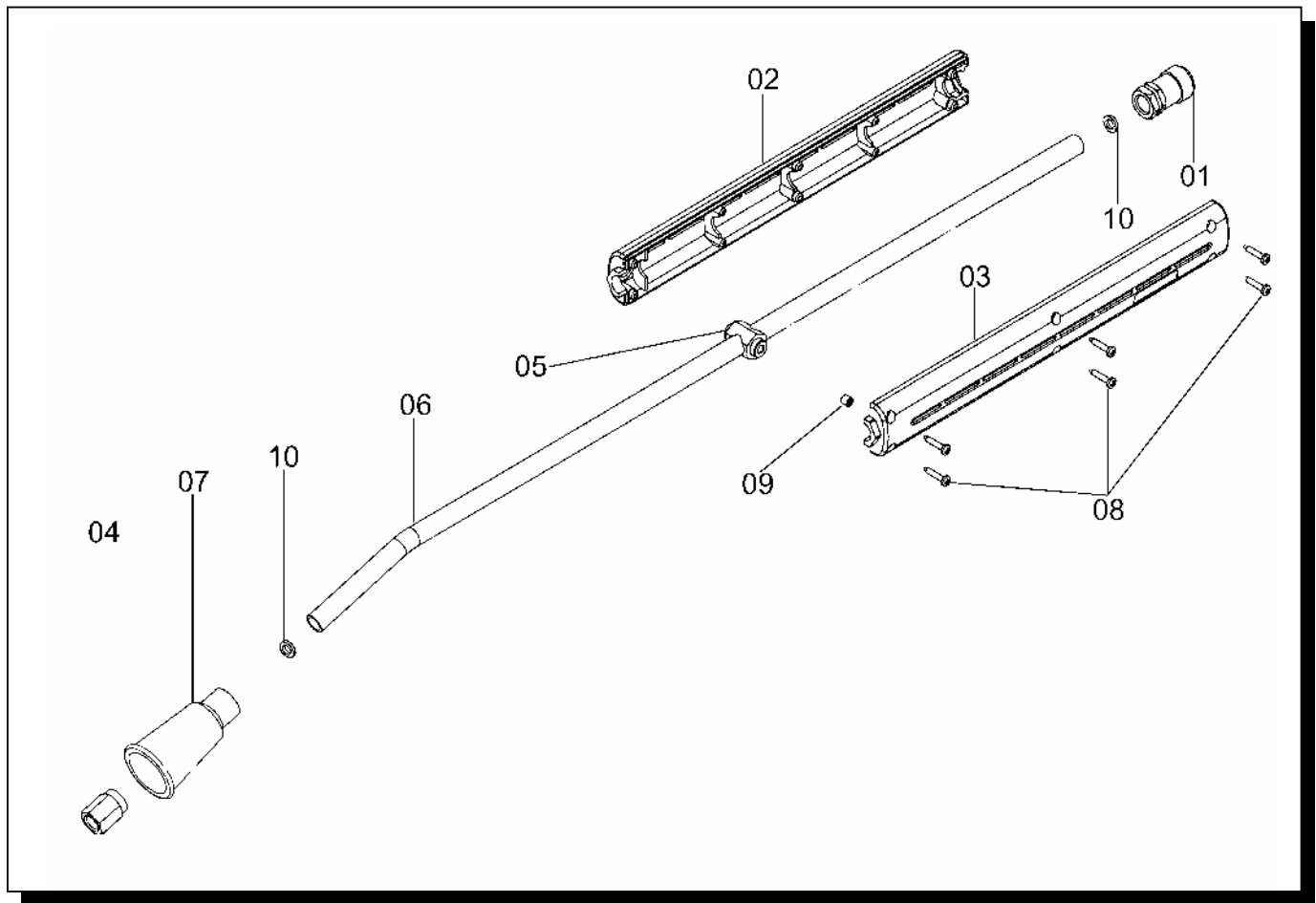

Pos.	Cod.	Descrizione	Description	Descripción	N°
01	1.001.02.046	Raccordo ARF 1/4" G	1/4" G ARF union	Racor ARF 1/4" G	1
02	1.017.02.003	Impugnatura superiore	Upper grip	Empunadura superior	1
03	1.017.02.004	Impugnatura inferiore	Lower grip	Empunadura inferior	1
04	1.019.02.010	Riduzione porta ugello	Nozzleholder reduction gear	Reduccion portatobera	1
05	1.036.02.006	Inserto lancia SC10	Lance insert	Inserto lanza	1
06	1.044.32.005	Tubo inox 13x1,5x700 1/4" G	Inox tube 13x1,5x700 1/4" G	Tubo inox 13x1,5x700 1/4" G	1
07	1.046.02.005	Protezione ugello	Nozze protection	Protección tobera	1
08	4.002.92.001	Vite Autofilettante 3,5x19	Self-tapping screw 3,5x19	Tornillo autoblocante 3,5x19	6
09	4.004.12.001	Vite STEI M6x6 UNI5923-67	STEI M6x6 UNI5923-67 screw	Tornillo STEI M6x6 UNI5923-67	1
10	4.008.12.003	Rondella rame 1/4" G	1/4" G copper washer	Arandola 1/4" G	2

PREMONTATO IDRO – PREASSEMBLED IDRO – PREESAMBLADO IDRO

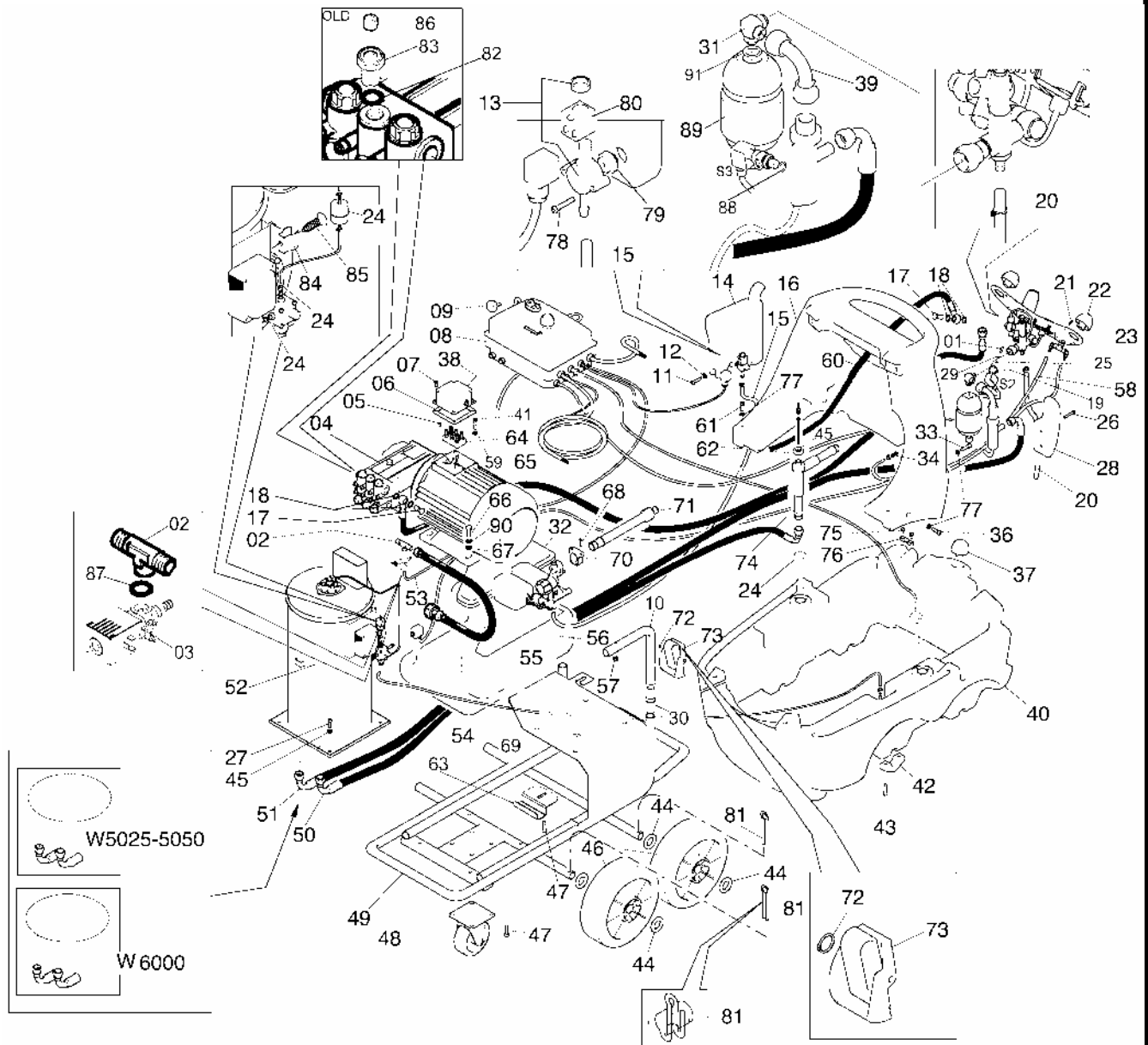

**PREMONTATO IDRO – PREASSEMBLED IDRO –
PREESAMBLADO IDRO**

Pos.	Cod.	Descrizione	<i>Description</i>	Descripción	N°
01	1.025.12.010	Molla pressostato	Pressure gauge spring	Muelle presostato	1
02a	1.001.24.018	Raccordo "T" W5025/W5050 "Hawk"	"T" connection W5025/W5050 "Hawk"	Racor "T" W5025/W5050 "Hawk"	1
02b	1.001.24.016	Raccordo "T" W5050 "Interpump"/W6000	"T" connection W5050 "Interpump"/W6000	Racor "T" W5050 "Interpump"/W6000	1
03	2.003.32.008	Elettrovalvola + portagomma	Electrovalve + hose fitting	Electroválvula + portamanguera	1
04a	3.006.12.054	Motopompa W5000 "Hawk"	Motorpump W5000 "Hawk"	Motobomba W5000 "Hawk"	1
04b	3.006.12.055	Motopompa W5000 "Interpump"	Motorpump W5000 "Interpump"	Motobomba W5000 "Interpump"	1
04c	3.006.12.070	Motopompa W5025	Motorpump W5025	Motobomba W5025	1
04d	3.006.12.057	Motopompa W5050 "Hawk"	Motorpump W5050 "Hawk"	Motobomba W5050 "Hawk"	1
04e	3.006.12.066	Motopompa W5050 "Interpump"	Motorpump W5050 "Interpump"	Motobomba W5050 "Interpump"	1
04f	3.006.12.053	Motopompa W6000	Motorpump W6000	Motobomba W6000	1
05	4.002.92.09	Vite M5x14	M5x14 screw	Tornillo M5x14	2
06	1.006.12.009	Guarnizione	Gasket	Empaquadera	1
07	4.002.14.037	Vite M6x12	M6x12 screw	Tornillo M6x12	4
08a	2.031.04.058	Quadro elettrico W5000	Electric pannel W5000	Tablero eléctrico W5000	1
08b	2.031.04.086	Quadro elettrico W5025/W5050	Electric pannel W5025/W5050	Tablero eléctrico W5025/W5050	1
08c	2.031.04.107	Quadro elettrico W6000	Electric pannel W6000	Tablero eléctrico W6000	1
09	1.021.04.009	Manopola	Knob	Pomo	1
10	2.064.04.001	Supporto quadro elettrico	Electric pannel support	Soporte tablero eléctrico	1
11	4.002.12.007	Vite M6x35	M6x35 screw	Tornillo M6x35	1
12	4.008.24.001	Rondella	Washer	Arandela	1
13	4.072.02.001	Elettrovalvola	Electrovalve	Electroválvula	1
14	1.033.04.011	Serbatoio anticalcare	Anti limestone tank	Tanque anti caliza	1
15	1.044.44.033	Tubo anticalcare	Anti limestone tube	Tubo anti caliza	1
16	1.033.04.017	Serbatoio detergente	Detergent tank	Tanque detergente	1
17	1.012.14.003	Tappo 3/8"G	3/8"G plug	Tapa 3/8"G	2
18	4.070.04.001	Rondella 3/8"G	3/8"G washer	Arandela 3/8"G	4
19	4.008.54.001	Rondella SCHNORR S4	S4 SCHNORR washer	Arandela SCHNORR S4	1
30	1.081.02.001	Forcella pressostato	Pressure gauge fork	Horquilla presostato	1
20	2.074.04.009	Tubo + fascetta	Tube + clamp	Tubo + faja	1
21	4.002.22.001	Vite M4x10	M4x10 screw	Tornillo M4x10	4
22	2.013.04.007	Tappo serbatoio	Tank plug	Tapa tanque	2
23	2.058.04.005	Pannello comandi	Console	Panel de mando	1
24	2.074.04.026	Tubo gasolio	Gas oil tube	Tubo gasoleo	1
25	4.005.22.003	OR pressostato	Pressure gauge O-Ring	OR presostato	1
26	4.002.12.008	Vite M6x25	M6x25 screw	Tornillo M6x25	4
27	4.002.11.002	Vite M8x25	M8x25 screw	Tornillo M8x25	3
28	1.126.04.001	Gancio universale	Universal hook	Gancho universal	2
29	4.008.02.002	Rondella pressostato	Pressure gauge washer	Arandela presostato	1
30	1.002.24.004	Perno	Pivot	Gozne	1
31	1.001.04.029	Raccordo 3 vie	3 way connection	Racor 3 vie	1
32	1.054.04.035	Coperchio serbatoio acqua	Water tank cover	Tapa tanque agua	1
33	4.002.12.009	Vite M8x35	M8x35 screw	Tornillo M8x35	2
34	2.033.02.002	Portagomma	Hose fitting	Portamanguera	1
35	4.008.24.002	Rondella	Washer	Arandela	9
36	4.002.12.004	Vite M8x30	M8x30 screw	Tornillo M8x30	2
37	2.013.04.013	Tappo serbatoio gasolio	Gas oil tank plug	Tapa tanque gasoleo	1
38	1.079.04.005	Copribasetta			1
39	4.012.04.009	Raccordo	Connection	Racor	1
40	1.033.04.018	Serbatoio gasolio	Gas oil tank	Taque gasoleo	1
41	4.002.94.021	Vite M5x10	M5x10 screw	Tornillo M5x10	1
42	1.089.04.023	Staffa fissaggio telaio	Frame fixing bracket	Estribo fijc3n estructura	4
43	4.002.14.026	Vite M8x18	M8x18 screw	Tornillo M8x18	8
44	1.003.04.006	Rondella	Washer	Arandela	8

**PREMONTATO IDRO – PREASSEMBLED IDRO –
PREESAMBLADO IDRO**

Pos.	Cod.	Descrizione	<i>Description</i>	<i>Descripción</i>	N°
45	4.008.12.003	Rondella rame 1/4" G	1/4" G copper washer	Arandela 1/4" G	1
46	1.086.04.016	Ruota	Wheel	Rueda	4
47	4.002.14.014	Vite M8x16	M8x16 screw	Tornillo M8x16	5
48	1.086.04.004	Ruota girevole	Revolving wheel	Rueda giratoria	1
49	2.015.04.007	Telaio	Frame	Estructura	1
50	2.006.04.023	Tubo uscita caldaia	Boiler out tube	Tubo uscita caldera	1
51	2.006.04.022	Tubo mandata caldaia	Boiler intake tube	Tubo envio caldera	1
52a	3.026.04.017	Caldaia W5000/W5025	Boiler W5000/W5025	Caldera W5000/W5025	1
52b	3.026.04.021	Caldaia W5050	Boiler W5050	Caldera W5050	1
52c	3.026.04.015	Caldaia W6000	Boiler W6000	Caldera W6000	1
53	2.074.04.030	Tubo aspirazione detergente	Detergent suction tube	Tubo de aspiración detergente	1
54	2.059.04.001	Pescante	Draft device	Sonda de aspiración	1
55	2.057.04.001	Galleggiante con filtro	Float with filter	Flotadores con filtro	1
56	1.100.04.004	Serbatoio acqua	Water tank	Tanque agua	1
57	4.009.14.002	Dado autobloccante	Self-locking nut	Tuerca autobloqueante	1
58	2.074.04.010	Tubo vitrex L450	Vitrex tube L450	Tubo vitrex L450	2
59	4.008.54.002	Rondella SCHNORR	SCHNORR washer	Arandela SCHNORR	1
60	2.006.04.020	Tubo by-pass	By-pass tube	Tubo by-pass	1
61	4.002.14.019	Vite M8x55	M8x55 screw	Tornillo M8x55	2
62	1.015.24.002	Ghiera	Ring nut	Tuerca	1
63	1.089.04.040	Staffa serbatoio acqua	Water tank stirrup	Estribo tanque agua	1
64	2.018.02.002	Morsettiera	Junction box	Terminal de conexión	1
65	2.006.04.021	Tubo	Tube	Tubo	1
66	4.002.44.006	Vite M10x40	M10x40 screw	Tornillo M10x40	4
67	4.008.04.004	Rondella	Washer	Arandela	4
68	4.002.24.003	Vite M6x16	Mx16 screw	Arandela M6x16	2
69	4.047.04.007	Inserto M10	M10 insert	Inserto M10	4
70	1.011.04.027	Supporto tubo aspirazione	Suction tube support	Soporte tubo de aspiración	1
71	2.063.04.001	Tubo aspirazione	Suction tube	Soporte tubo	1
72	4.025.04.009	Seeger esterno	External seeger	Seeger esterno	1
73	2.052.04.002	Freno	Brake	Freno	1
74	2.048.04.004	Collettore	Manifold	Colector	1
75	4.002.92.006	Vite M4x12	M4x12 screw	Tornillo M4x12	2
76	1.045.04.006	Pressacavo	Cable gland	Prensacable	1
77	2.013.04.019	Tappo scarico	Discharge plug	Tapa escape	1
78	4.002.14.013	Vite M4x30	M4x30 screw	Tornillo M4x30	2
79	1.006.14.006	Guarnizione serbatoio	Tank gasket	Empaquetadura tanque	1
80	4.040.02.002	Bobina	Spool	Bobina	1
81	4.044.04.004	Copiglia	Pin	Espina	4
82	4.005.22.026	OR 3081	O-Ring 3081	OR 3081	1
83a	4.036.04.005	Tappo VAM "Hawk"	VAM plug "Hawk"	Tapa VAM "Hawk"	1
83b	4.036.04.008	Tappo VAM "Interpump"	VAM plug "Interpump"	Tapa VAM "Interpump"	1
84	1.011.02.003	Portafiltro	Filter-holder	Portafiltro	1
85	4.002.94.015	Vite autofilettante 3,9x9,5	3,9x9,5 self-tapping screw	Tornillo autobloccante 3,9x9,5	1
86	1.006.11.007	Rondella nylon	Nylon washer	Arandela nylon	1
87	4.005.12.008	OR 114	O-Ring 114	OR 114	1
88	4.008.12.002	Rondella rame 13x19x1,5	13x19x1,5 copper washer	Arandela 13x19x1,5	1
89	3.040.04.002	Accumulatore	Accumulator	Accumulador	1
90	4.008.54.003	Rondella grower	Grower washer	Arandela grower	4
91	4.008.14.004	Rondella rame 18x24x1,5	18x24x1,5 copper washer	Arandela 18x24x1,5	1

PREMONTATO CALDAIA W5000/W5025/W5050 –
PREASSEMBLED BOILER W5000/W5025/W5050 –
PREENSAMBLADO CALDERA W5000/W5025/W5050

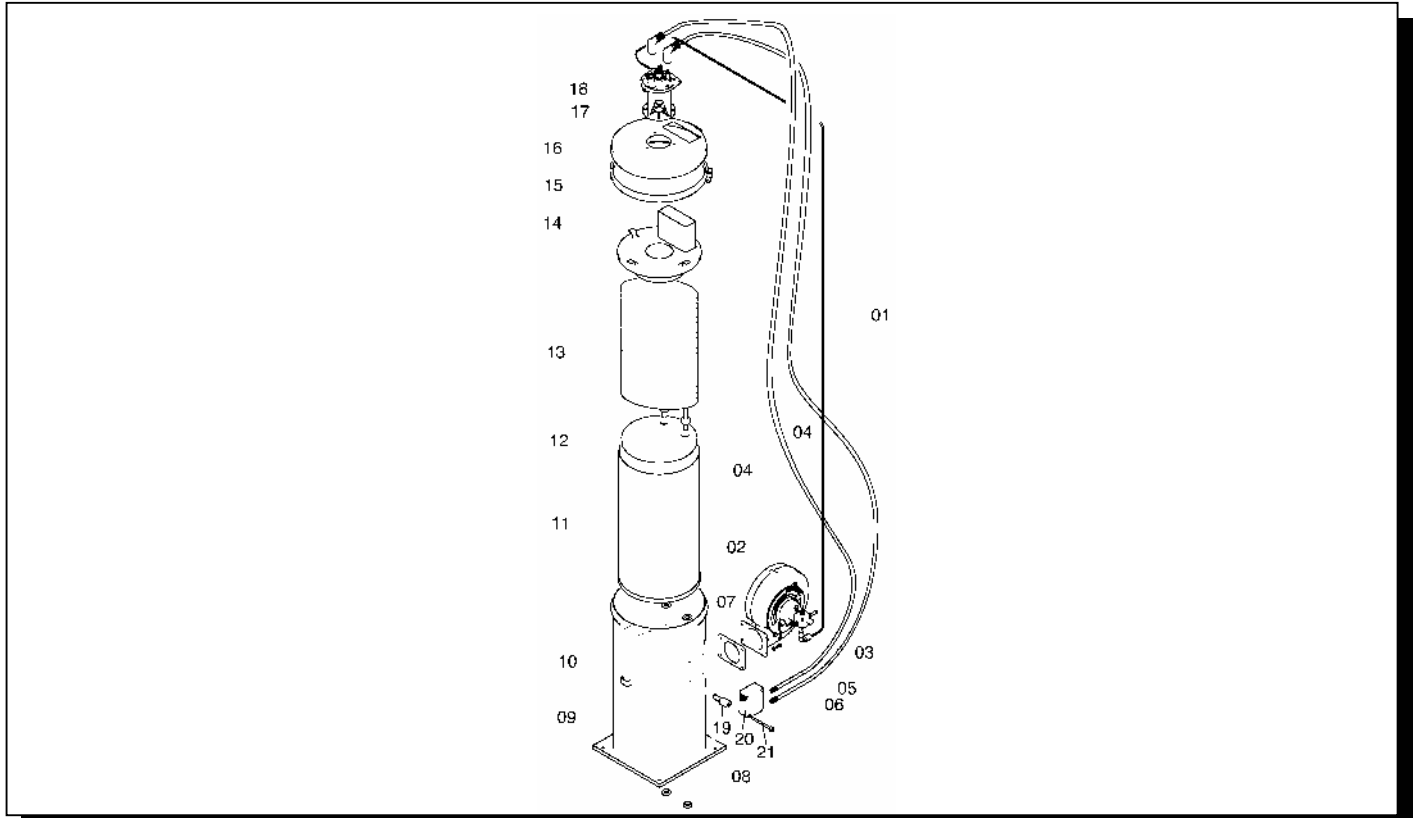

Pos.	Cod.	Descrizione	Description	Descripción	N°
01	1.044.54.003	Tubo rame gasolio	Gas oil copper tube	Tubo gasoleo	1
02a	3.038.02.003	Convogliatore W5000/W5025	Conveyor W5000/W5025	Conveyor W5000/W5025	1
02b	3.038.02.005	Convogliatore W5050	Conveyor W5050	Conveyor W5050	1
03	3.050.14.001	Raccordo tubo gasolio	Gas oil tube connection	Racor tubo gasoleo	1
04	2.020.04.012	Cavo trasformatore	Transformer wire	Cable transformador	2
05	4.002.44.001	Vite M6x20	M6x20 screw	Tornillo M6x20	2
06	4.008.24.001	Rondella	Washer	Arandela	2
07	1.006.04.001	Guarnizione	Gasket	Empaquetadura	1
08	1.015.24.002	Ghiera	Ring nut	Abrazadera	2
09	2.023.04.013	Camicia esterna	External jacket	Camisa externa	1
10	1.060.04.018	Distanziale 6mm	6mm spacer	Distanciador 6mm	2
11	2.023.04.010	Camicia interna	Internal jacket	Camisa interior	1
12	1.094.04.005	Isolante	Insulator	Aislante	1
13	2.029.04.008	Serpentina	Warming	Serpent	1
14	2.012.04.013	Camino	Chimney	Chimenea	1
15	2.056.04.001	Fascetta	Clamp	Faja	1
16	1.054.04.006	Coperchio	Cover	Tapa	1
17a	2.012.04.019	Pr. elettrodi W5000/W5025	Pr. electrodes W5000/W5025	Pr. electrodos W5000/W5025	1
17b	2.012.04.025	Premontato elettrodi W5050	Preassembled electrodes W5050	Preensamblado electrodos W5050	1
18	4.002.94.017	Vite autofilettante 3,9x13	3,9x13 self-tapping screw	Tornillo autobloccante 3,9x13	3
19	1.011.04.013	Supporto trasformatore	Transformer support	Soporte transformador	2
20	4.030.04.001	Trasformatore	Transformer	Transformador	1
21	4.002.14.009	Vite M4x50	M4x50 screw	Tornillo M4x50	2

PREMONTATO CONVOGLIATORE W5000/W5025/W5050 –
PREASSEMBLED CONVEYOR W5000/W5025/W5050 –
PREESAMBLADO TRANSPORTADOR W5000/W5025/W5050

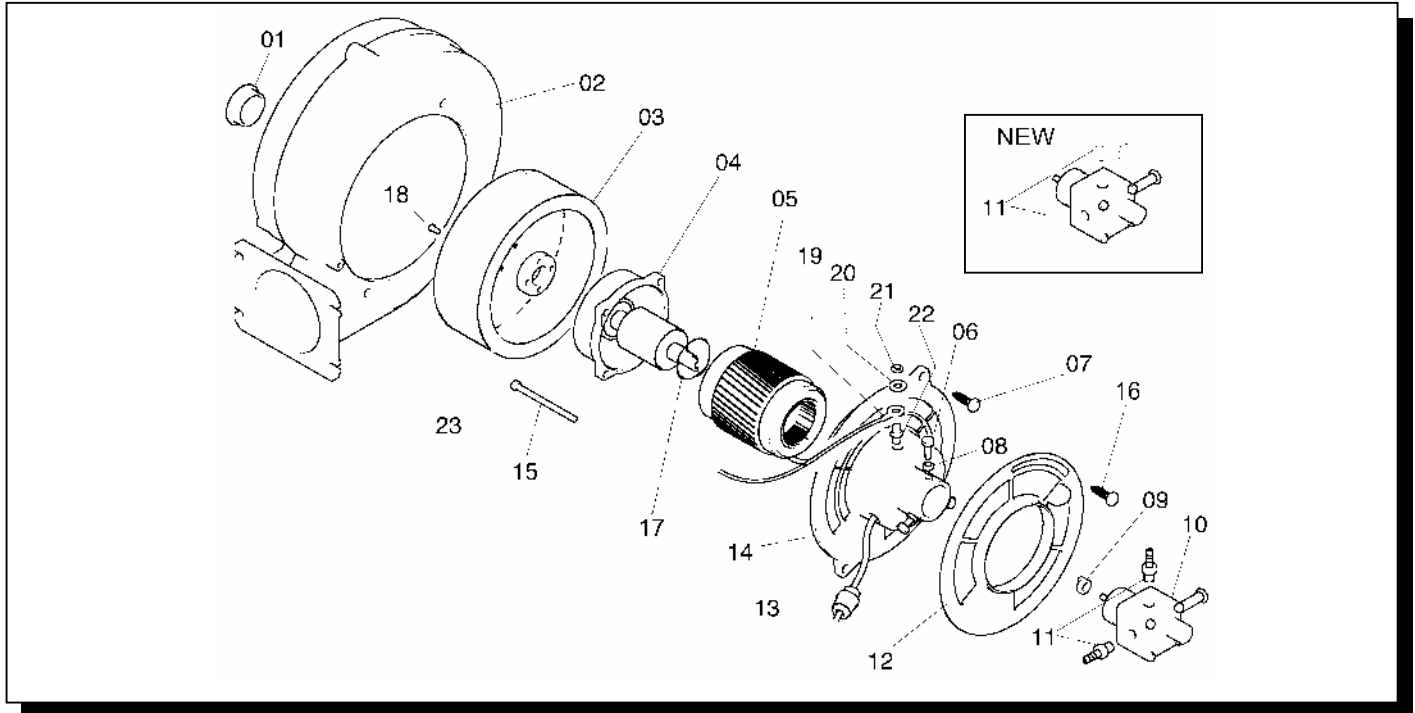

Pos.	Cod.	Descrizione	Description	Descripción	N°
01	4.036.02.002	Tappo	Plug	Tapa	1
02a	2.017.02.001	Carter convogliatore W5000/W5025	Conveyor guard W5000/W5025	Cartér transportador W5000/W5025	1
02b	2.017.22.002	Carter convogliatore W5050	Conveyor guard W5050	Cartér transportador W5050	1
03a	1.073.02.006	Ventola W5000/W5025	Fan W5000/W5025	Ventilador W5000/W5025	1
03b	1.073.04.008	Ventola W5050	Fan W5050	Ventilador W5050	1
04	2.014.02.030	Albero + rotore	Shaft + rotor	Eje + rotor	1
05	2.025.22.001	Statore	Stator	Estátor	1
06	1.004.04.001	Vite M5x20	M5x20 screw	Tornillo M5x20	3
07	4.002.92.007	Vite autofilettante 6,3x16	6,3x16 self-tapping screw	Tornillo autobloccante 6,3x16	2
08	4.009.02.001	Dado M5	M5 nut	Tuerca M5	3
09	1.098.02.001	Giunto	Coupling	Junta	1
10	3.015.24.007	Pompa gasolio	Gas oil pump	Bomba gasoleo	1
11a	2.033.02.002	Portagomma	Hose-fitting	Portamanguera	2
11b	2.012.04.013	Raccordo	Connection	Racor	2
12	1.009.02.004	Griglia controllo aria	Air check grate	Rejilla de control aire	1
13	2.027.02.004	Pressacavo	Cable clamping device	Prensacable	1
14a	1.074.02.025	Flangia W5000/W5025	Flange W5000/W5025	Brida W5000/W5025	1
14b	1.074.02.028	Flangia W5050	Flnge W5050	Brida W5050	1
15	4.002.12.016	Vite M4x45	M4x45 screw	Tornillo M4x45	4
16	4.002.94.012	Vite flangiata	Flanged screw	Tornillo con brida	2
17	4.049.12.005	Anello di compensazione			1
18a	4.002.72.004	Vite M3x6 W5000/W5025	M3x6 screw W5000/W5025	Tornillo M3x6 W5000/W5025	4
18b	4.002.72.004	Vite M3x25 W5050	M3x25 screw W5050	Tornillo M3x25 W5050	4
19	2.020.14.088	Cavo di terra	Ground wire	Cable de tierra	1
20	4.008.52.002	Rondella	Washer	Arandela	1
21	4.009.04.003	Dado M8	M8 nut	Tuerca M8	1
22	1.004.22.002	Vite messa a terra	Ground screw	Tornillo de tierra	1
23	1.060.02.006	Distanziale W5050	Spacer W5050	Distanciador W5050	1

**PREMONTATO CALDAIA W6000 – PREASSEMBLED BOILER W6000 –
PREENSAMBLADO CALDERA W6000**

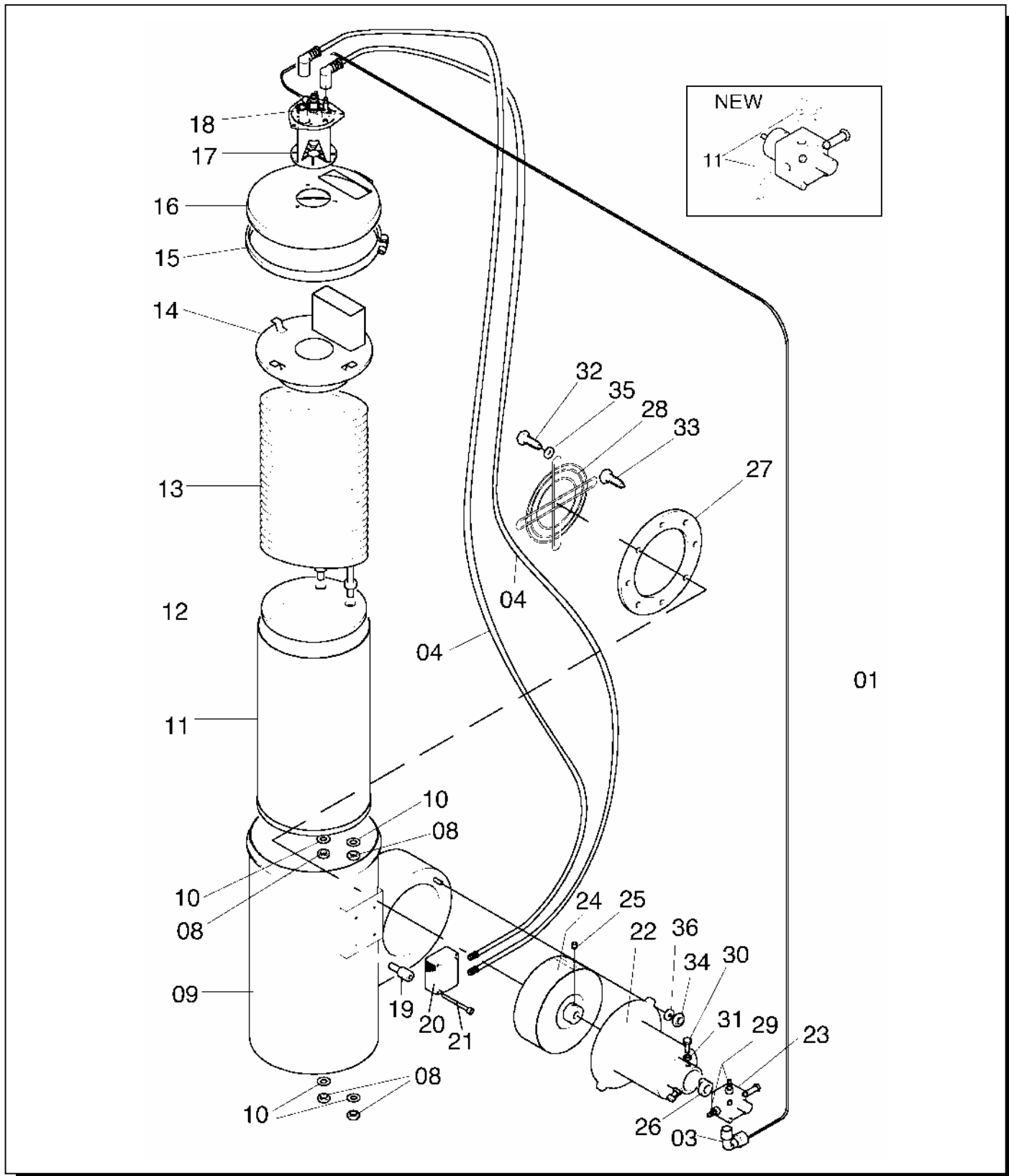

**PREMONTATO CALDAIA W6000 – PREASSEMBLED BOILER W6000 –
PREENSAMBLADO CALDERA W6000**

Pos.	Cod.	Descrizione	<i>Description</i>	Descripción	N°
01	1.044.54.008	Tubo rame gasolio	Gas oil copper tube	Tubo gasoleo	1
02					
03	3.050.14.001	Raccordo tubo gasolio	Gas oil tube connection	Racor tubo gasoleo	1
04	2.020.04.075	Cavo trasformatore	Transformer wire	Cable transformador	2
05					
06					
07					
08	1.015.24.002	Ghiera	Ring nut	Abrazadera	4
09	2.023.04.15	Camicia esterna	External jacket	Camisa externa	1
10	4.008.24.003	Distanziale	Spacer	Distanciador	4
11	2.023.04.017	Camicia interna	Internal jacket	Camisa interior	1
12	1.094.04.013	Isolante	Insulator	Aislante	1
13	2.029.04.010	Serpentina	Warming	Serpent	1
14	2.012.04.017	Camino	Chimney	Chimenea	1
15	2.056.04.002	Fascetta	Clamp	Faja	1
16	1.054.04.028	Coperchio	Cover	Tapa	1
17	2.012.04.018	Premontato elettrodi	Preassembled electrodes	Preensamblado electrodos	1
18	4.002.94.017	Vite autofilettante 3,9x13	3,9x13 self-tapping screw	Tornillo autoblocante 3,9x13	3
19	1.011.04.013	Supporto trasformatore	Transformer support	Soporte transformador	2
20	4.030.04.001	Trasformatore	Transformer	Transformador	1
21	4.002.14.009	Vite M4x50	M4x50 screw	Tornillo M4x50	2
22	3.002.24.008	Motore ventilatore	Fan motor	Motor ventilador	1
23	3.015.24.008	Pompa gasolio	Gas oil pump	Bomba gasoleo	1
24	1.073.04.009	Ventola	Fan	Ventilador	1
25	4.004.14.002	Grano	Grub screw	Grano	1
26	1.098.04.004	Giunto	Coupling	Junta	1
27	1.056.04.018	Boccaglio	Mouthpiece	Boquilla	1
28	1.009.04.002	Griglia	Grate	Rejilla	1
29a	1.049.04.003	Portagomma	Hose-fitting	Portamanguera	2
29b	2.012.04.013	Raccordo	Connection	Racor	2
30	1.004.04.001	Vite M5x20	M5x20 screw	Tornillo M5x20	3
31	4.009.02.001	Dado M5	M5 nut	Tuerca M5	3
32	4.002.94.008	Vite autofilettante M3,5x13	M3,5x13 self-tapping screw	Tornillo autoblocante M3,5x13	3
33	4.002.94.003	Vite autofilettante M3,5x9,5	M3,5x9,5 self-tapping screw	Tornillo autoblocante M3,5x9,5	3
34	4.009.12.001	Dado autoblok M8	Autoblok M8 nut	Tuerca autoblok M8	2
35	4.008.04.007	Rondella M4	M4 washer	Arandela M4	3
36	4.008.04.002	Rondella M8	M8 washer	Arandela M8	2

COPERCHIO PORTA ELETTRODI – ELECTRODES HOLDER – TAPA PORTAELECTRODOS

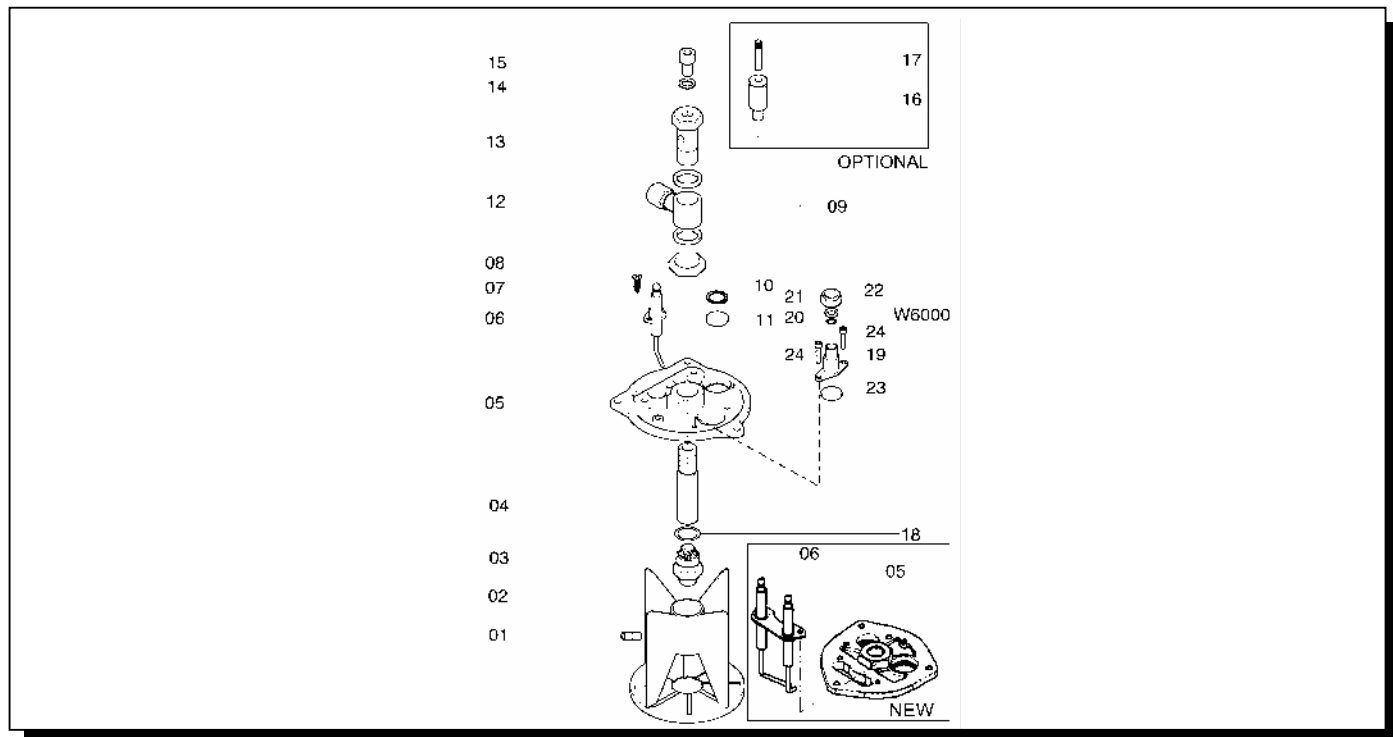

Pos.	Cod.	Descrizione	Description	Descripción	N°
01	4.004.34.001	Grano	Grub nut	Grano	1
02	2.009.04.002	Deflettore	Deflector	Deflector	1
03a	4.027.14.011	Ugello W5000/W5025	Nozzle W5000/W5025	Tobera W5000/W5025	1
03b	4.027.14.012	Ugello W5050	Nozzle W5050	Tobera W5050	1
03c	4.027.14.013	Ugello W6000	Nozzle W6000	Tobera W6000	1
04	1.001.04.006	Raccordo porta ugello	Nozzle holder	Racor porta tobera	1
05a	1.074.04.003	Flangia elettrodo singolo	Single electrode flange	Brida elettrodo singolo	1
05b	1.074.04.011	Flangia doppio elettrodo	Double electrodes flange	Brida dos electrodos	1
06a	2.032.04.003	Elettrodo	Electrode	Elettrodo	2
06b	2.032.04.004	Doppio elettrodo	Double electrodes	Elettrodos doppio	1
07	4.002.94.005	Vite autofilettante M3,9x13	M3,9x13 self-tapping screw	Tornillo autobloccante M3,9x13	2
08	1.015.24.003	Ghiera	Ring nut	Abrazadera	1
09	4.008.12.005	Rondella rame	Copper washer	Arandela	2
10	4.025.04.002	Seeger	Seeger	Seeger	1
11	1.102.04.001	Vetrino	Glass	Vidrio	1
12	3.050.34.001	Raccordo	Connection	Racor	1
13	1.012.14.016	Tappo	Plug	Tapa	1
14	4.008.14.003	Rondella rame	Copper washer	Arandela	2
15	4.002.14.022	Vite M5x10	M5x10 screw	Tornillo M5x10	1
16	4.012.04.006	Raccordo controllo pressione	Pressure control union	Conector rápido	1
17	4.036.04.007	Tappo	Plug	Tapa	1
18	4.005.14.004	OR	O-Ring	OR	1
19	1.074.04.005	Flangia controllo fiamma	Flame control flange	Brida sensor de temperatura	1
20	4.005.22.009	OR 3024	O-Ring 3024	OR 3024	1
21	4.008.02.001	Rondella	Washer	Arandela	1
22	1.015.32.008	Ghiera	Ring-nut	Tuerca	1
23	1102.04.003	Vetrino controllo fiamma	Flame control glass	Vidrio sesor de temperatura	1
24	4.002.72.001	Vite M5x12	M5x12 screw	Tornillo M5x12	2

**PREMONTATO GALLEGGIANTE CON FILTRO – PREASSEMBLED
FLOAT WITH FILTER – PREENSAMBLADO FLOTADOR CON FILTRO**

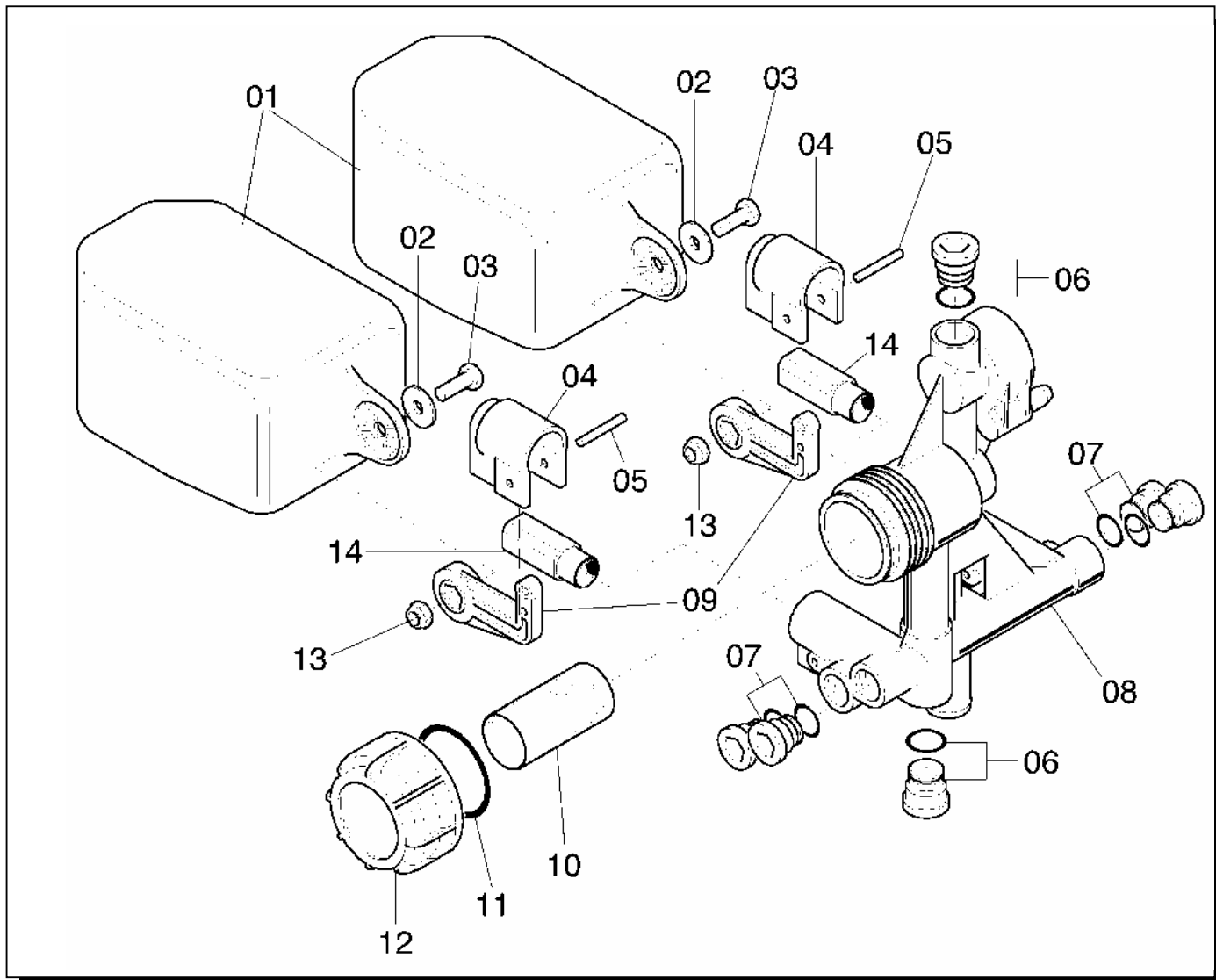

Pos.	Cod.	Descrizione	Description	Descripción	N°
01	1.103.04.001	Galleggiante	Float	Flotador	2
02	4.008.04.003	Rondella	Washer	Arandola	2
03	4.002.44.003	Vite	Screw	Tornillo	2
04	1.112.04.002	Calotta per galleggiante con freno	Float cap with brake	Tapa para flotador con freno	2
05	1.013.14.002	Spina cilindrica	Cylindrical pin	Vástago cilindrico	2
06	2.013.04.016	Tappo 3/8"G	3/8"G plug	Tapa 3/8"G	2
07	2.013.04.015	Tappo 1/4"G	1/4"G plug	Tapa 1/4"G	4
08	2.048.04.009	Collettore	Manifold	Colector	1
09	1.016.04.002	Leva per galleggiante	Float pivot	Palanca para flotador	2
10	1.030.04.003	Filtro a rete	Net filter	Filtro de red	1
11	4.005.31.015	OR 3131	O-Ring 3131	OR3131	1
12	1.012.04.007	Tappo porta filtro	Filter plug	Tapòn portafiltro	1
13	4.009.12.002	Dado esagonale	Hexagonal nut	Turca hexagonal	2
14	2.002.04.002	Otturatore galleggiante	Float shutter	Obturador flotador	2
15	1.006.14.003	Guarnizione	Basket	Empaquetadura	1

TUBO ASPIRAZIONE – SUCTION TUBE – TUBO DE ASPIRACIÓN

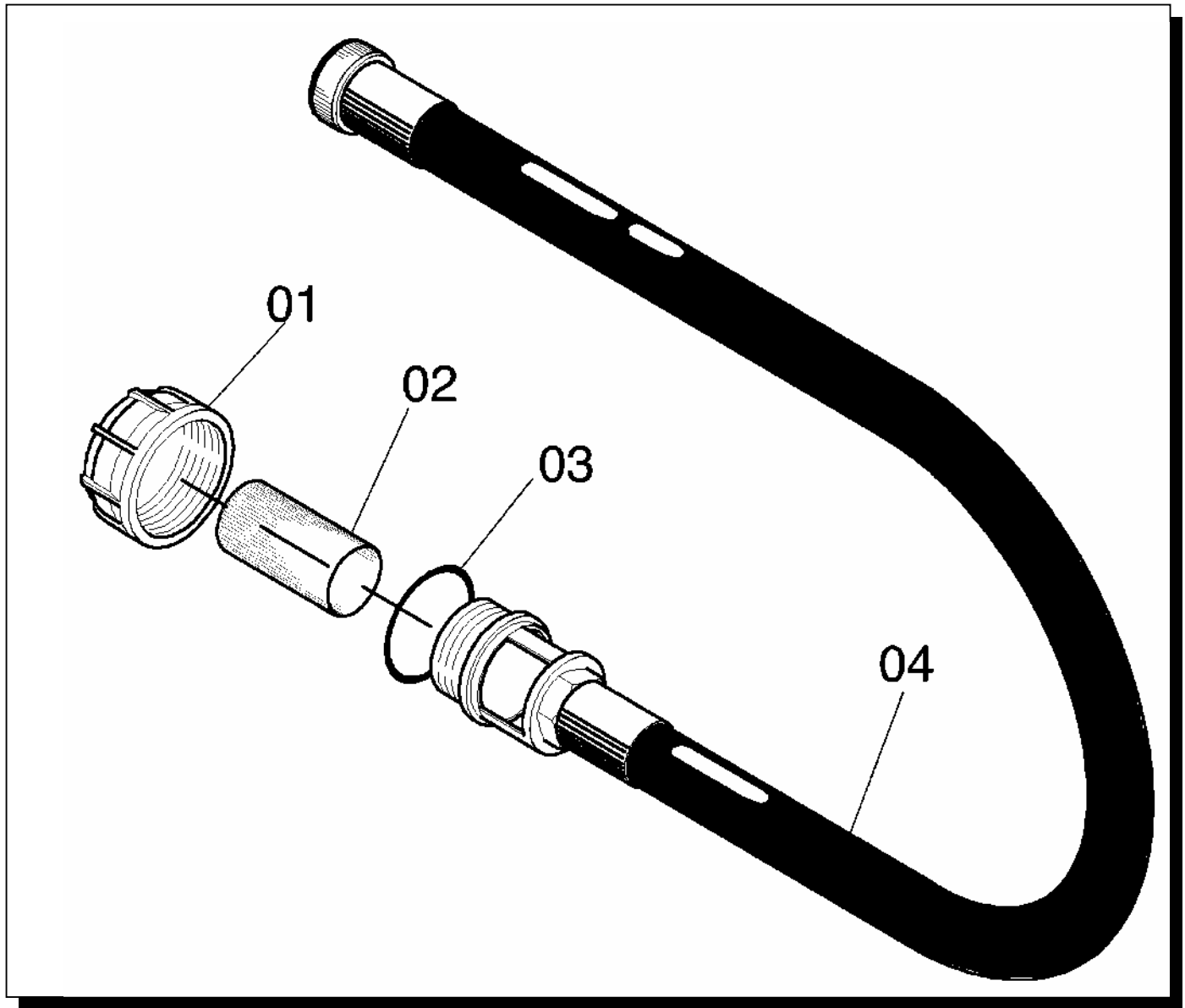

Pos.	Cod.	Descrizione	Description	Descripción	N°
01	1.012.04.007	Tappo	Plug	Tapón	1
02	1.030.04.003	Filtro	Filter	Filtro	1
03	4.005.31.015	Guarnizione	Gasket	Empaquetadura	1
04	2.074.04.002	Tubo	Tube	Tubo	1
05	4.005.21.018	Guarnizione	Gasket	Empaquetadura	1
06	4.005.21.003	Guarnizione	Gasket	Empaquetadura	1

VALVOLA SICUREZZA – SAFETY VALVE – VÁLVULA DE SEGURIDAD

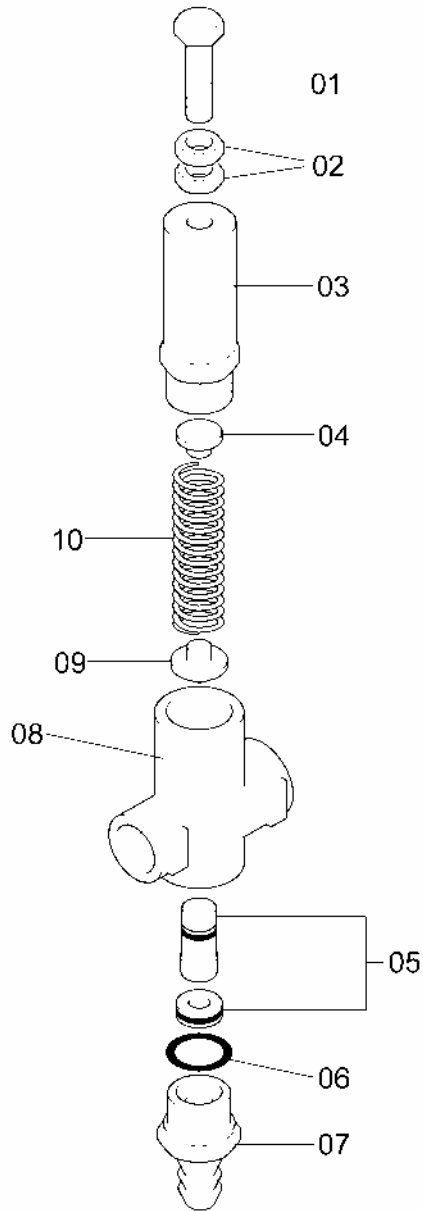

Pos.	Cod.	Descrizione	Description	Descripción	N°
01	4.002.42.003	Vite M8x30	M8x30 screw	Tornillo M8x30	1
02	4.009.04.003	Dado M8	M8 nut	Tuerca M8	2
03	1.021.02.011	Manopola	Grip	Pomo	1
04	1.072.02.011	Premimolla superiore	Upper springpress device	Sujeta-resorte superior	1
05	9.005.02.004	Kit ricambio otturatore	Shutter spare kit	Kit repuestos obturador	1
06	4.005.21.011	Guarnizione	Gasket	Empaquetadura	1
07	1.049.02.007	Portagomma	Tube holder	Portagoma	1
08	1.020.22.014	Corpo valvola di sicurezza	Safety valve body	Cuerpo válvula de seguridad	1
09	1.072.02.012	Premimolla inferiore	Lower springpress device	Sujeta-resorte inferior	1
10	1.025.22.007	Molla valvola di sicurezza	Safety valve spring	Muelle válvula de seguridad	1

PREMONTATO PANNELLO COMANDI – PREEASSEMBLED CONTROL PANEL – PREENSAMBLADO PANEL MANDOS

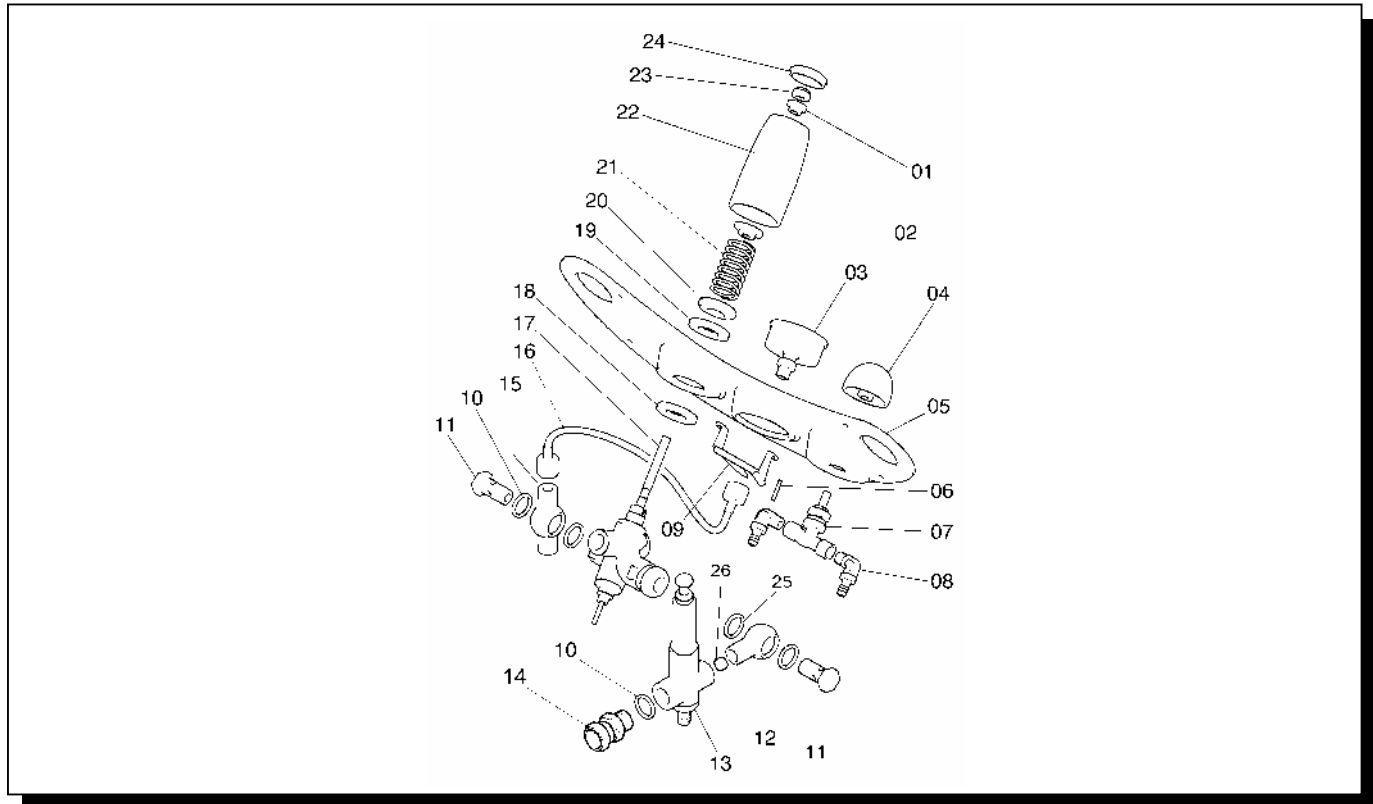

Pos.	Cod.	Descrizione	Description	Descripción	Nº
01	1.036.02.001	Inserto manopola	Knob insert	Inserción pomo	1
02	1.072.02.004	Premimolla valvola	Valve springpress	Sejeta-resorte válvula	1
03	4.020.14.002	Manometro	Pressure gauge	Manómetro	1
04	1.021.04.008	Manopola detergente	Detergent knob	Pomo detergente	1
05	1.111.04.002	Pannello comandi	Control panel	Panel mandos	1
06	4.004.32.002	Grano	Grub screw	Grano	2
07	3.003.34.001	Valvola detergente	Detergent valve	Válvula detergente	1
08	1.049.04.003	Portagomma	Hose-fitting	Portamanguera	2
09	1.089.04.003	Staffa manometro	Pressure gauge bracket	Brida manómetro	1
10	4.070.04.001	Rondella	Washer	Arandela	3
11	1.012.14.003	Tappo	Plug	Tapa	2
12	1.001.34.015	Occhiello	Eyelet	Argolla	1
13	3.003.22.002	Valvola di sicurezza	Safety valve	Válvula de seguridad	1
14	4.012.04.002	Raccordo	Connection	Racor	1
15	1.031.04.005	Occhiello doppio	Double eyelet	Argolla doppio	1
16	2.006.24.006	Tubo manometro	Pressure gauge tube	Tubo manómetro	1
17	2.003.34.005	Valvola VRB	VRB valve	Válvula VRB	1
18	1.003.04.007	Rondella inferiore VRB	VRB lower washer	Arndela inferior VRB	1
19	1.003.04.008	Rondella superiore VRB	VRB upper washer	Arandela superior VRB	1
20	1.015.02.019	Ghiera	Ring nut	Abrazadera	1
21	1.025.22.001	Molla blu	Blue spring	Muelle azul	1
22	1.021.02.012	Manopola VRB	VRB knob	Pomo VRB	1
23	4.009.12.001	Dado	Nut	Tuerca	1
24	1.012.02.005	Tappo manopola	Knob plug	Tapón pomo	1
25	4.008.12.001	Rondella rame	Copper washer	Arandela	2
26	1.006.22.001	Guarnizione	Gasket	Empaquetadura	1

VALVOLA BY-PASS – BY-PASS VALVE – VÁLVULA BY-PASS

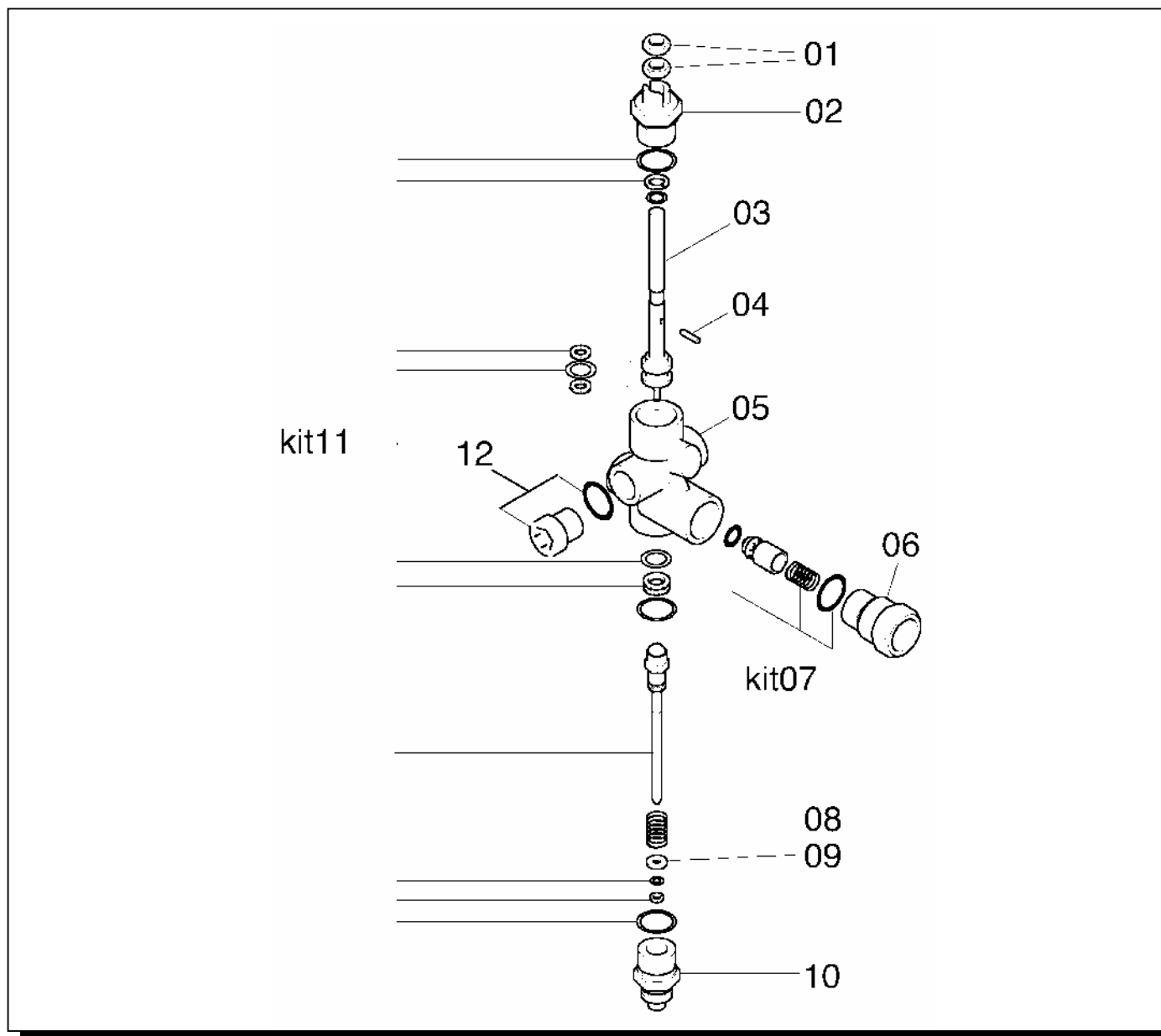

Pos.	Cod.	Descrizione	Description	Descripción	N°
01	1.035.02.001	Dado massima pressione	Max pressure nut	Tuerca maxima presión	2
02	1.001.02.002	Raccordo guida stelo	Stem guide connection	Racor guía de vastago	1
03	1.037.02.001	Stelo VRB	VRB stem	Vastago VRB	1
04	4.011.12.001	Spina elastica	Elastic pin	Espina elástico	1
05	1.020.22.020	Corpo VRB	VRB body	Cuerpo VRB	1
06	1.001.02.003	Raccordo mandata	Delivery connection	Conexión envío	1
07	9.005.02.001	Otturatore mandata	Outlet shutter	Obturador	1
08	1.025.12.002	Molla	Spring	Muelle	1
09	1.003.02.004	Rondella	Washer	Arandela	1
10	1.001.02.024	Raccordo pressostato	Pressure gauge connection	Racor presostato	1
11	9.003.02.007	Kit tenuta Totalstop	Totalstop spare seals kit	Kit cerres Totalstop	
12	2.013.04.016	Tappo	Plug	Tapa	1

PREMONTATO QUADRO ELETTRICO – PREEASSEMBLED SWITCHBOARD – PREENSAMBLADO PANEL MANDOS

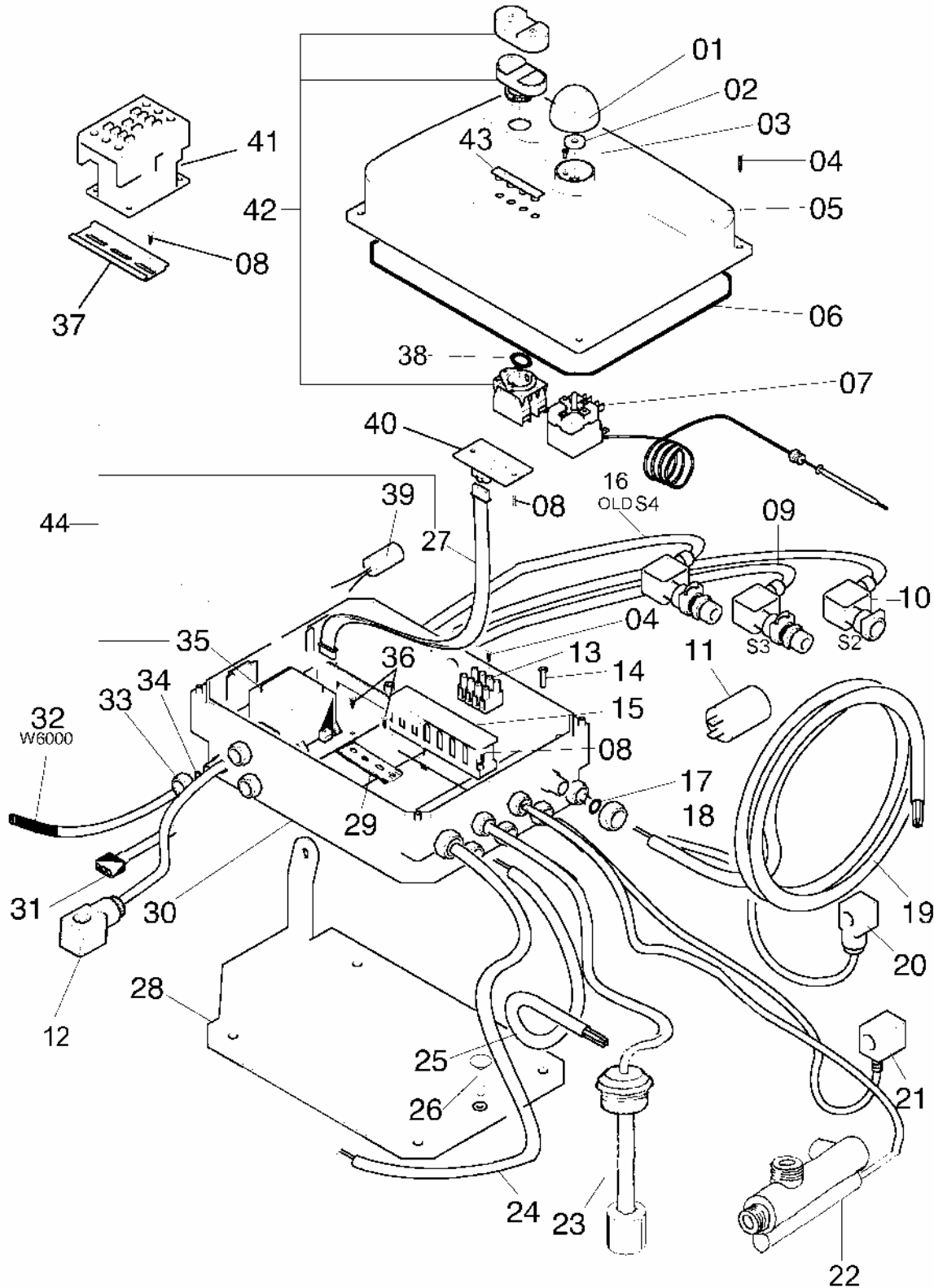

PREMONTATO QUADRO ELETTRICO – PREEASSEMBLED SWITCHBOARD – PREENSAMBLADO PANEL MANDOS

Pos.	Cod.	Descrizione	Description	Descripción	N°
01	1.021.04.006	Manopola	Hand grip	Pomo	1
02	1.006.14.001	Guarnizione manopola	Hand grip gasket	Empaquetadura pomo	1
03	4.002.22.001	Vite M4x10	M4x10 screw	Tornillo M4x10	2
04	4.002.92.001	Vite autofilettante 3,5x19	3,5x19 self tapping screw	Tornillo autoblocante 3,5x19	6
05	1.054.04.022	Coperchio quadro elettrico	Switchboard cover	Tapa panel mandos	1
06	1.006.14.004	Guarnizione	Gasket	Empaquetadura	1
07	4.031.04.003	Termostato	Thermostat	Termostato	1
08	4.002.94.015	Vite autofilettante 3,9x9,5	3,9x9,5 self tapping screw	Tornillo autoblocante 3,9x9,5	6
09	3.013.04.002	Pressostato S3 (DDS)	Pressare gauge S3 (DDS)	Presostato S3 (DDS)	1
10	2.008.04.001	Pressostato S2 (TST)	Pressure gauge S2 (TST)	Presostato S2 (TST)	1
11	4.035.04.002	Condensatore	Condenser	Condensador	1
12	2.080.04.004	Connettore detergente	Detergent connector	Conector detergente	1
13	4.003.04.031	Morsetti	Junction box	Terminal de conexión	1
14	4.002.18.006	Vite M6x8	M6x8 crew	Tornillo M6x8	4
15	1.110.04.001	Canala cablata	Wired raceway	Canal cableado	1
16	3.013.02.002	Pressostato S4 (detergente)	Pressure gauge S4 (chemical)	Presostato S4 (detergente)	1
17	4.005.22.009	OR 3024	O-Ring 3024	OR 3024	2
18	1.015.32.011	Ghiera	Ring nut	Abrazadera	2
19	2.020.04.056	Cavo elettrico	Electric wire	Cable eléctrico	1
20	2.080.04.002	Connettore anticalcare	Anti-limestone connector	Conector anticalizia	1
21	2.083.04.001	Bobina gasolio	Gas oil spool	Bobina gasoleo	1
22	2.086.04.002	Flussostato	Flow switch	Flusostato	1
23	3.030.02.006	Livellostato	Leveller	Nivelador	1
24	2.020.04.055	Cavo elettrico	Electric wire	Cable eléctrico	1
25	2.020.04.057	Cavo termico	Thermal cable	Cable termico	1
26	4.002.04.005	Vite M10x55	M10x55 screw	Tornillo M10x55	1
27	2.020.32.002	Cavo piatto	Multiwire	Connexión electrica multipla	1
28	1.011.04.029	Supporto quadro elettrico	Switchboard support	Soporte panel mandos	1
29	1.128.04.003	Barra messa a terra	Ground bar	Barra de tierra	1
30	1.078.04.017	Scatola elettrica	Electric box	Caja eléctrica	1
31	2.020.04.030	Cavo trasformatore	Transformer wire	Cable transformador	1
32	2.082.04.002	Sonda controllo fiamma W6000	Flame control probe W6000	Sonda control de flama W6000	1
33	1.015.32.008	Ghiera	Ring nut	Abrazadera	1
34	4.005.22.012	OR 2-105	O-Ring 2-105	OR 2-105	1
35	3.024.02.019	Scheda MCC15	MCC15 card	Ficha MCC15	1
36	4.002.092.003	Vite autofilettante 3,5x10	3,5x10 self tapping screw	Tornillo autoblocante 3,5x10	2
37	1.011.04.033	Supporto con barra	Support with rod	Soporte con barra	1
38	4.005.22.025	OR 3075	O-Ring 3075	OR 3075	1
39	1.030.04.004	Filtro capacitivo	Capacitive filter	Filtro con capacidad	1
40	3.024.02.019	Scheda LED	LED card	Ficha LED	1
41a	4.042.04.020	Teleruttore W5000/W5025	Electromagnetic switch W5000/W5025	Teleruptor W5000/W5025	1
41b	4.042.04.019	Teleruttore W5050/W6000	Electromagnetic switch W5050/W6000	Teleruptor W5050/W6000	1
42	4.018.04.008	Interruttore	Switch	Interruptor	1
43	1.102.04.002	Vetro spia	Spy glass	Cristal para indicadores	1
44a	9.021.04.002	Kit ricambio scheda MCC15 W5000/W5025/W5050	MCC15 card spare kit W5000/W5025/W5050	Kit repuestos ficha MCC15 W5000/W5025/W5050	1
44b		Kit ricambio scheda MCC15 W5000	MCC15 card spare kit W5000	Kit repuestos ficha MCC15 W5000	1

COMPRESSIVO MOTOPOMPA – MOTORPUMP LAYOUT – ESQUEMA GENERAL MOTOBOMBA

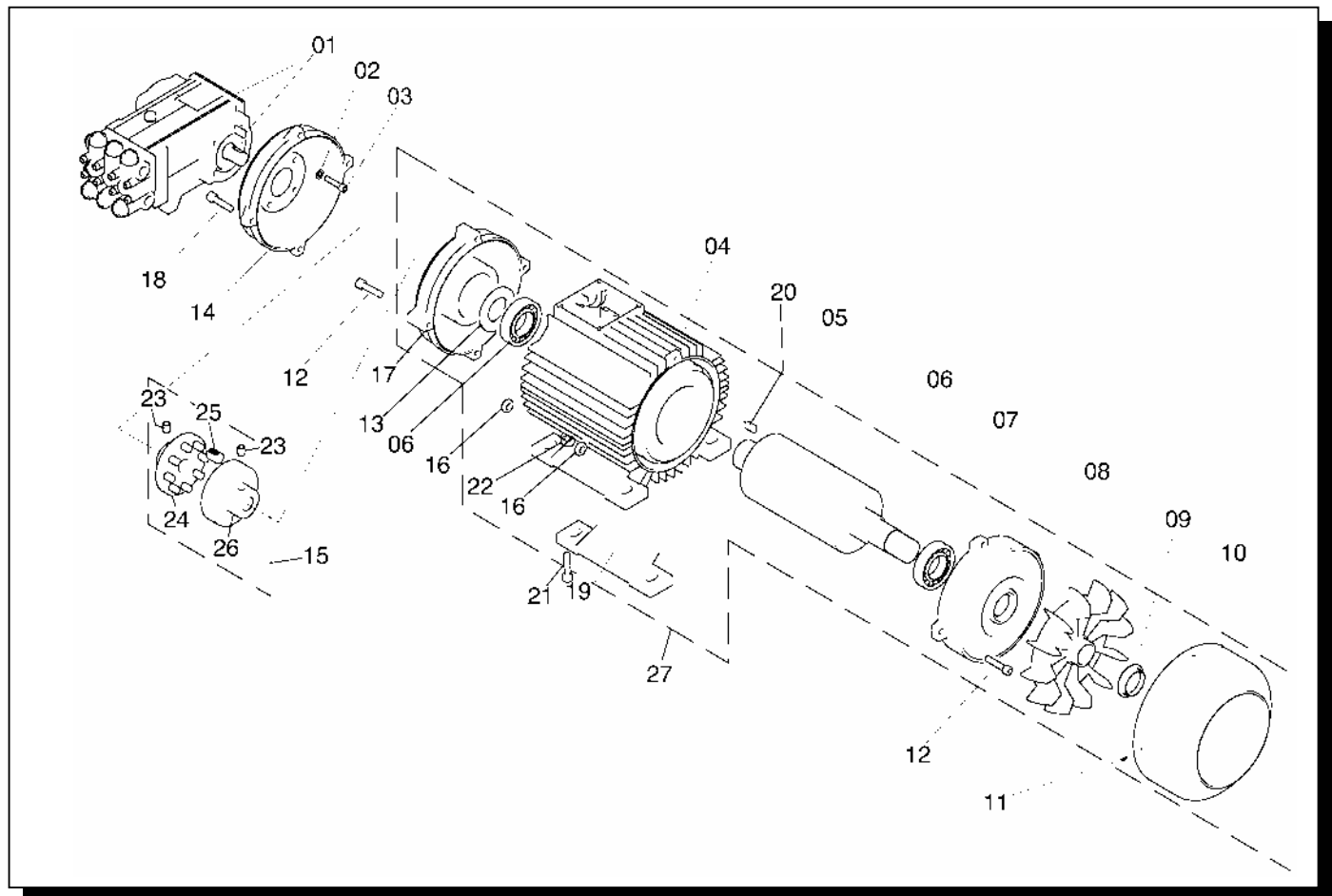

Pos.	Cod.	Descrizione	Description	Descripción	Nº
01a	3.015.12.045	Motopompa W5000 "Hawk"	Motorpump W5000 "Hawk"	Motobomba W5000 "Hawk"	1
01b	3.015.12.030	Motopompa W5025 "Hawk"	Motorpump W5025 "Hawk"	Motobomba W5025 "Hawk"	1
01c	3.015.12.020	Motopompa W5050 "Hawk"	Motorpump W5050 "Hawk"	Motobomba W5050 "Hawk"	1
01d	3.015.12.022	Motopompa W5000 "Interpump"	Motorpump W5000 "Interpump"	Motobomba W5000 "Interpump"	1
01e	3.015.12.029	Motopompa W5050 "Interpump"	Motorpump W5050 "Interpump"	Motobomba W5050 "Interpump"	1
01f	3.015.12.034	Motopompa W6000 "Interpump"	Motorpump W6000 "Interpump"	Motobomba W6000 "Interpump"	1
02	4.008.52.002	Rondella	Washer	Arandela	4
03a	4.002.12.002	Vite M8x25 W5000	M8x25 screw W5000	Tornillo M8x25 W5000	4
03b	4.008.12.004	Vite M8x30 W5025/W5050/W6000	M8x30 screw W5025/W5050/W6000	Tornillo M8x30 W5025/W5050/W6000	4
04a	2.017.02.021	Premontato carter W5000	Preassembled casing W5000	Preensamblado cárter W5000	1
04b	2.017.02.020	Premontato carter W5025/W5050/W6000	Preassembled casing W5025/W5050/W6000	Preensamblado cárter W5025/W5050/W6000	1
05a	2.014.02.044	Premontato albero W5000	Preassembled shaft W5000	Preensamblado eje W5000	1
05b	2.014.02.043	Premontato albero W5025/W5050/W6000	Preassembled shaft W5025/W5050/W6000	Preensamblado eje W5025/W5050/W6000	1
06	4.016.02.007	Cuscinetto	Bearing	Cojinete	2
07	1.074.02.012	Flangia posteriore	Back flange	Brida posterior	1
08	1.073.02.005	Ventola	Fan	Ventilador	1
09	1.045.02.007	Fascetta	Clamp	Faja	1
10	1.046.02.017	Protezione ventola	Fan protection	Protección ventilador	1
11	4.002.94.007	Vite autofilettante 4,2x13	4,2x13 self tapping screw	Tornillo autoblocante 4,2x13	4
12	4.002.12.018	Vite M8x45	M8x45 screw	Tornillo M8x45	4

COMPLESSIVO MOTOPOMPA – MOTORPUMP LAYOUT – ESQUEMA GENERAL MOTOBOMBA

Pos.	Cod.	Descrizione	<i>Description</i>	Descripción	N°
13	4.049.12.004	Anello	Ring	Anillo	1
14	1.074.02.031	Flangia anteriore	Front flange	Brida anterior	1
15	3.055.02.001	Giunto	Coupling	Junta	1
16	4.009.12.001	Dado M8	M8 nut	Tuerca M8	6
17	1.074.02.032	Flangia	Flange	Brida	1
18	4.002.12.021	Vite M8x85	M8x85 screw	Tornillo M8x85	4
19	1.145.02.001	Piede carcassa	Foot	Piede carcassa	2
20	4.021.02.003	Chiavetta	Cotter	Chaveta	1
21	4.002.42.008	Vite M10x50	M10x50 screw	Tornillo M10x50	4
22	4.009.14.002	Dado M10	M10 nut	Tuerca M10	4
23	4.004.42.005	Grano	Grub screw	Grano	1
24	1.131.02.009	Mozzo Ø24	Ø24 hub	Cubo Ø24	1
25	1.157.02.001	Ammortizzatore giunto	Coupling cushion	Amortiguador junta	12
26	1.131.02.010	Mozzo Ø38	Ø38 hub	Cubo Ø38	1
27a	3.002.12.030	Motore elettrico W5000	Electric motor W5000	Motor eléctrico W5000	1
27b	3.002.12.029	Motore elettrico W5025/W5050/W6000	Electric motor W5025/W5050/W6000	Motor eléctrico W5025/W5050/W6000	1



KRÜGER TECHNOLOGY S.L.
B-82526583
Polígono Agustinos C/G Parcela B2
31013 Pamplona (Navarra) - ESPAÑA
+34 948 343 393 - info@kruger.es - www.kruger.es